

NOTES:

1. $\text{\textcircled{C}}$ REPRESENTS A CRITICAL DIMENSION.
2. TERMINALS TO BE SHEARED TO MEET DIMENSION SPECIFICATION.
3. PARTS MAY BE CUT TO POSITION.
4. MINIMUM PUSHOUT FORCE: .5 LB.
5. EJ OPTION IS NOT AVAILABLE AS OF REVISION AG.
APPLICABLE VIEWS ARE REMAINING FOR REFERENCE TO BUILD INTERNAL ASP ORDERS ONLY. THIS OPTION WAS FOR EXISTING BUSINESS ONLY. ANY EXISTING CUSTOMERS WILL HAVE PART NUMBERS SETUP AS INTERNAL ASP'S.
6. MAX BURR ALLOWANCE: .003" [.08"]
7. MAX CUT FLASH: .010 [.25"]
8. MAX HEIGHT VARIATION BETWEEN ROWS: .005 [.13"]

DO NOT SCALE FROM THIS PRINT

FTSH-1XX-XX-XX-D-XX-XX

No OF POSITIONS
-02 THRU -50
(PER ROW)

LEAD STYLE

- 01: .120 [3.05]
- 02: .075 [1.91]
- 03: .065 [1.65] MIN
- 04: .150 [3.81]

PLATING SPECIFICATION

- F: 3 μ " SELECTIVE GOLD IN CONTACT AREA, MATTE TIN ON TAIL
- L: 10 μ " SELECTIVE GOLD IN CONTACT AREA, MATTE TIN ON TAIL
- S: 30 μ " SELECTIVE GOLD IN CONTACT AREA, MATTE TIN ON TAIL
- H: 30 μ " HEAVY GOLD IN CONTACT AREA, 3 μ " GOLD ON TAIL
- FM: 3 μ " SELECTIVE GOLD IN CONTACT AREA, MATTE TIN ON TAIL
- LM: 10 μ " SELECTIVE GOLD IN CONTACT AREA, MATTE TIN ON TAIL
- SM: 30 μ " SELECTIVE GOLD IN CONTACT AREA, MATTE TIN ON TAIL
- LTL: 10 μ " SELECTIVE GOLD IN CONTACT AREA, 90 / 10 \pm 5% TIN LEAD ON TAIL

OPTIONS

- ES: END SHROUDS
(-02 & -03 LEAD STYLE ONLY- SEE FIG 2, SHT 2)
(9 POS PER ROW MIN)
(MUST USE FTSH-50-D)
- EL: SHROUD LOCK
(-02 & -03 LEAD STYLE ONLY- SEE FIG 4, SHT 2)
(9 POS PER ROW MIN)
(USE ONLY WHEN MATING WITH CLP)
(MUST USE FTSH-50-D)
- EP: GUIDE POST
(-02 & -03 LEAD STYLE ONLY- SEE FIG 5, SHT 2)
(9 POS PER ROW MIN)
(USE ONLY WHEN MATING WITH CLP)
(MUST USE FTSH-50-D)
- EJ: EJECTOR SHROUD
(SEE FIG 3, SHT 2)
(SEE NOTE 5)
(MUST USE FTSH-50-D)
- K: KEYING SHROUD
(-01 LEAD STYLE ONLY- SEE FIG 1, -K OPTION)
(POS 05, 08, 10, 13, 15, 17, 20, 25 ONLY)
(USE ONLY WITH -RA TAIL OPTION)
(MUST USE FTSH-XX-CN-XX)

TAIL OPTION

- RA: RIGHT ANGLE
- FC: FLEX CARD (MUST USE FTSH-50-D)
(-01 LEAD STYLE ONLY, FOR USE WITH FCF)
- FE: FLEX CARD ELEVATED (MUST USE FTSH-50-D)
(-01 LEAD STYLE ONLY, FOR USE WITH FCF)

ROW SPECIFICATION

- D: DOUBLE ROW
(USE **FTSHC-1XX-XX-XXX-D-RA UNLESS OPTION IS SPECIFIED, THEN USE BODY CALLED OUT UNDER OPTION AND BUILD PER PRINT. SEE OPTIONS FOR BODY CALLOUT)

** = SEE FTSHC-1XX-XX-XXX-DX-XX PRINT FOR DETAILS

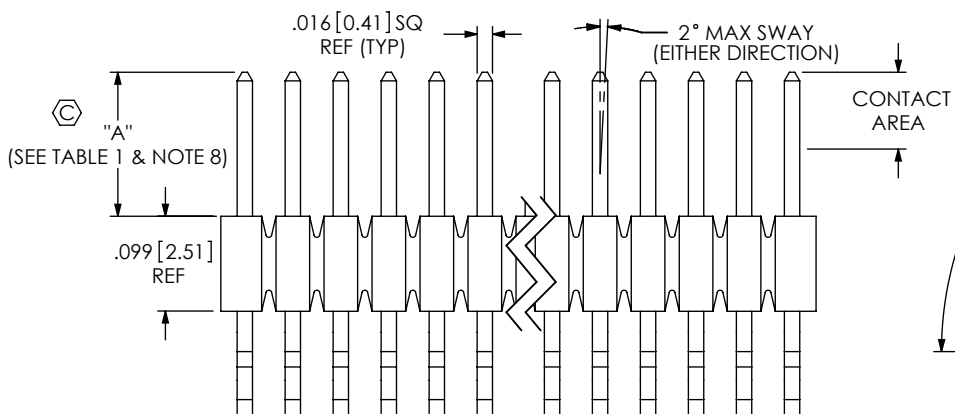
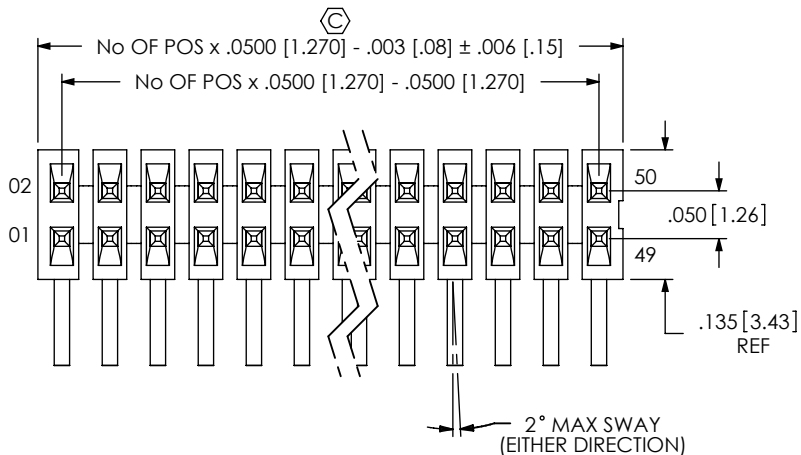
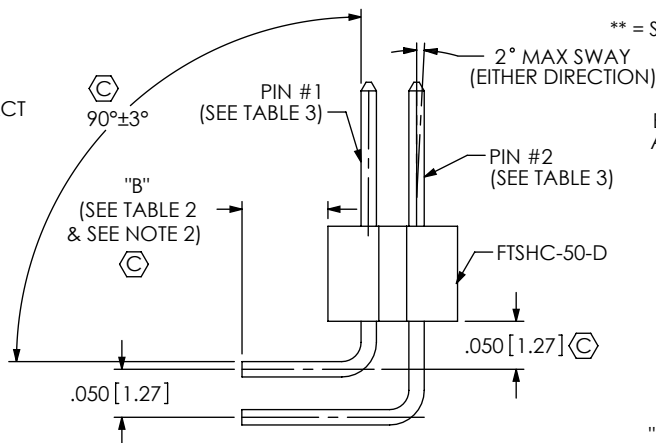
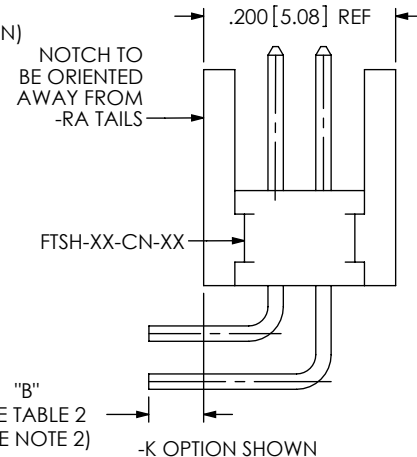

FIG 1
FTSHC-1XX-XX-XXX-D-RA SHOWN
(SEE FTSHC-1XX-XX-XXX-DX-XX PRINT FOR DETAILS)



-RA OPTION SHOWN



-K OPTION SHOWN

TABLE 1	
POST HEIGHT	"A"
-01	.120 [3.05]
-02	.075 [1.91]
* -03	.065 [1.65]
-04	.150 [3.81]

TABLE 2			
OPTIONS	"B" ± .010		
NONE, -RA, -RA-K	.090	2.290	
-EP, -ES, -EL	.120	3.08	
-EJ	.135	3.43	
-FC	.150	3.81	
-FE (SEE NOTE)	.283	7.19	

TABLE 3		
TAIL OPTION	PIN #1	PIN #2
-RA	T-1S15-64-XX	T-1S15-63-XX
-RA -K	T-1S15-64-XX	T-1S15-68-XX
-FC	T-1S15-07-XX	T-1S15-08-XX
-FE	T-1S15-03-XX	T-1S15-03-XX

UNLESS OTHERWISE SPECIFIED, DIMENSIONS ARE IN INCHES.
TOLERANCES ARE:
DECIMALS ANGLES
.XX: ±.01 [.3] 1°
.XXX: ±.005 [1.3]
.XXXX: ±.0010 [.025]

PROPRIETARY NOTE

THIS DOCUMENT CONTAINS INFORMATION CONFIDENTIAL AND PROPRIETARY TO SAMTEC, INC. AND SHALL NOT BE REPRODUCED OR TRANSFERRED TO OTHER DOCUMENTS OR DISCLOSED TO OTHERS OR USED FOR ANY PURPOSE OTHER THAN THAT WHICH IT WAS OBTAINED WITHOUT THE EXPRESSED WRITTEN CONSENT OF SAMTEC, INC.

MATERIAL: DO NOT SCALE DRAWING SHEET SCALE: 5:1
INSULATOR: BLACK LIQUID CRYSTAL POLYMER
TERMINAL: PHOSPHOR BRONZE, ALLOY No. 510

F:\DWG\MISC\MKTG\FTSH-1XX-XX-XX-D-XX-XX-MKT.SLDDRW



520 PARK EAST BLVD, NEW ALBANY, IN 47150
PHONE: 812-944-6733 FAX: 812-948-5047
e-Mail: info@SAMTEC.com code 53322

DESCRIPTION:
.050 x .050 C.L. DOUBLE HORIZONTAL TERMINAL STRIP
DWG. NO.
FTSH-1XX-XX-XX-D-XX-XX
BY: BRATCHER 08/17/1995 SHEET 1 OF 3

FIG 2
-ES OPTION
AVAILABLE IN LEAD STYLE -02 & -03 ONLY
(DIFFERENT AS SHOWN, OTHERWISE SAME AS FIG 1)

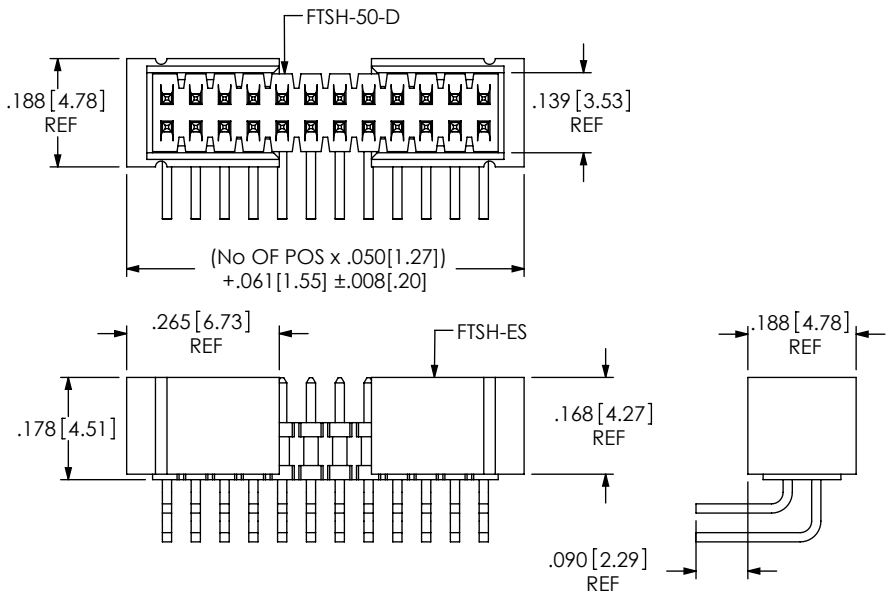

FIG 3
-EJ OPTION
(FOR EXISTING CUSTOMERS ONLY)
AVAILABLE IN LEAD STYLE -01 ONLY
(DIFFERENT AS SHOWN, OTHERWISE SAME AS FIG 1)
(SEE NOTE 5 ON SHEET 1)

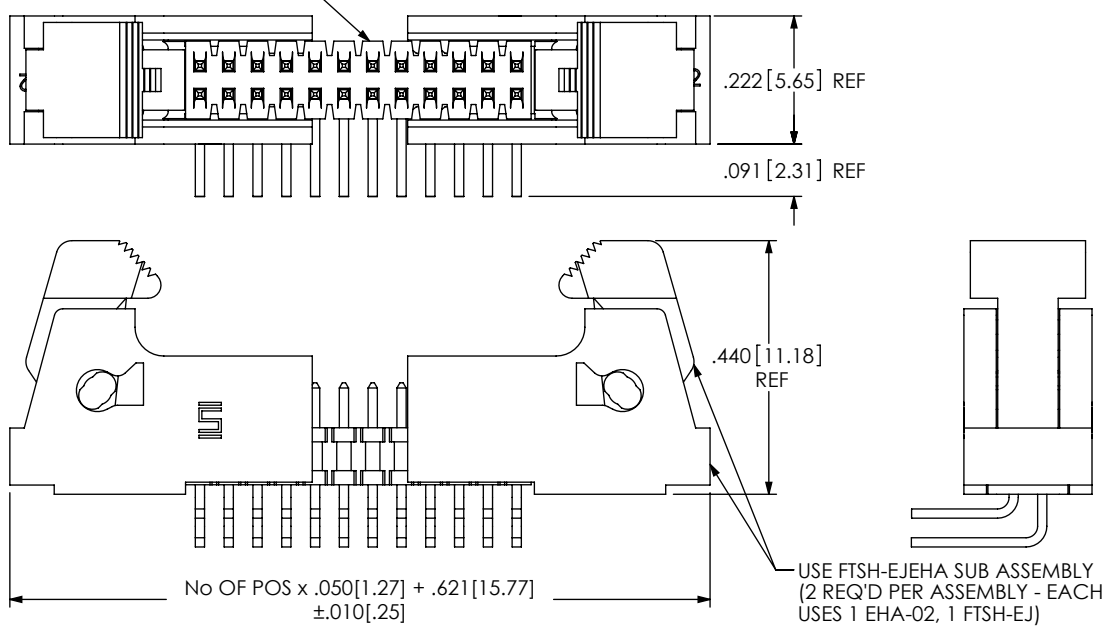

FIG 4
-EL OPTION
(USE ONLY WHEN MATING WITH CLP)
(DIFFERENT AS SHOWN, OTHERWISE SAME AS FIG 2)

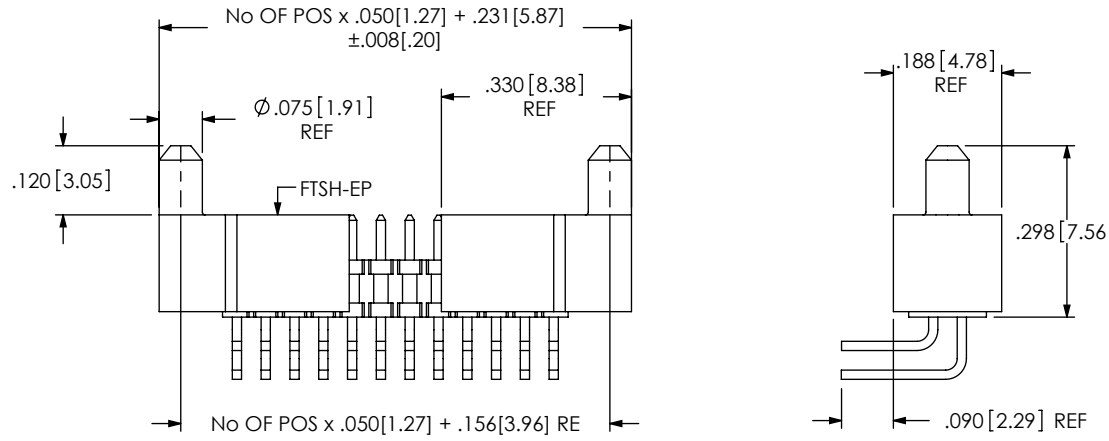
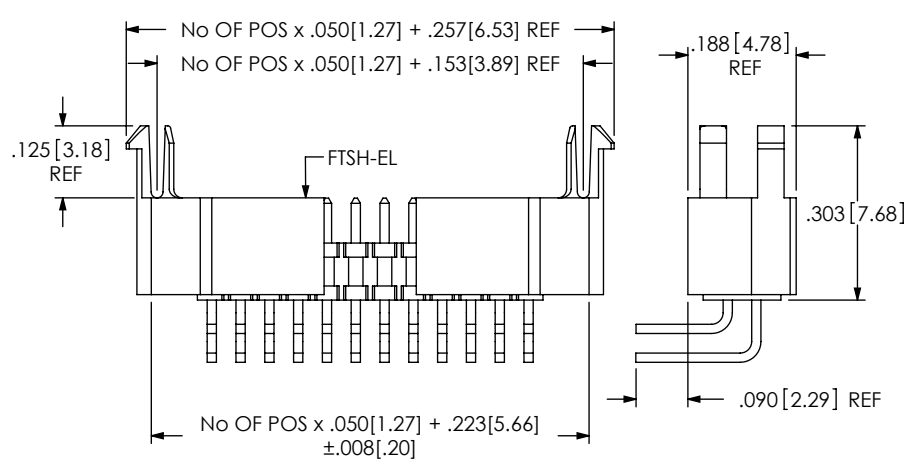

FIG 5
-EP OPTION
(USE ONLY WHEN MATING WITH CLP)
(DIFFERENT AS SHOWN, OTHERWISE SAME AS FIG 2)

PROPRIETARY NOTE
THIS DOCUMENT CONTAINS INFORMATION CONFIDENTIAL AND PROPRIETARY TO SAMTEC, INC. AND SHALL NOT BE REPRODUCED OR TRANSFERRED TO OTHER DOCUMENTS OR DISCLOSED TO OTHERS OR USED FOR ANY PURPOSE OTHER THAN THAT WHICH IT WAS OBTAINED WITHOUT THE EXPRESSED WRITTEN CONSENT OF SAMTEC, INC.

DO NOT SCALE DRAWING
SHEET SCALE: 2:1

F:\DWG\MISC\MKTG\FTSH-1XX-XX-XX-D-XX-XX-MKT.SLDDRW



520 PARK EAST BLVD, NEW ALBANY, IN 47150
PHONE: 812-944-6733 FAX: 812-948-5047
e-Mail: info@SAMTEC.com code 53322

DESCRIPTION:
.050 x .050 C.L. DOUBLE HORIZONTAL TERMINAL STRIP

DWG. NO.
FTSH-1XX-XX-XX-D-XX-XX

BY: BRATCHER 08/17/1995 SHEET 2 OF 3

PACKAGING TUBES

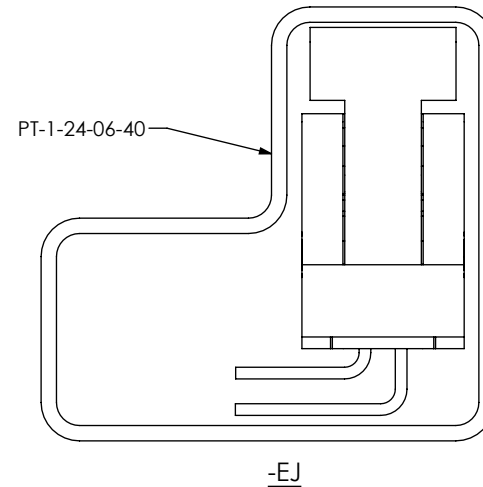
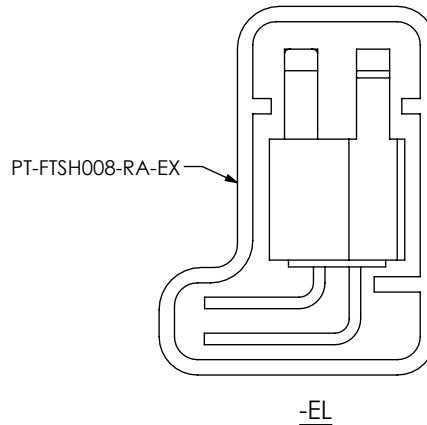
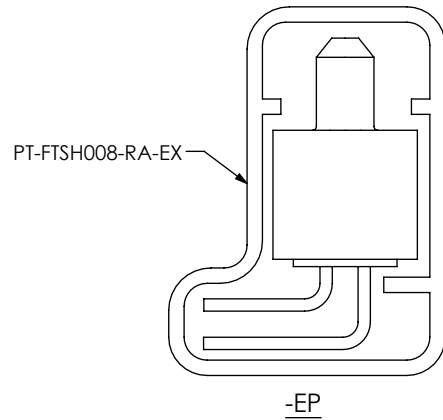
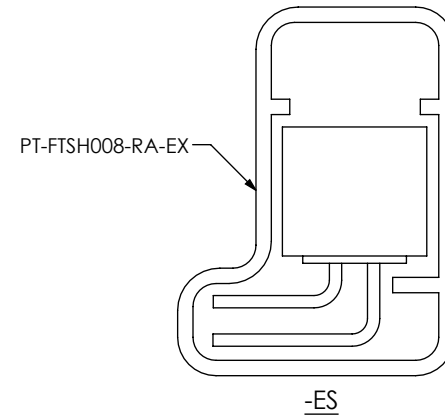
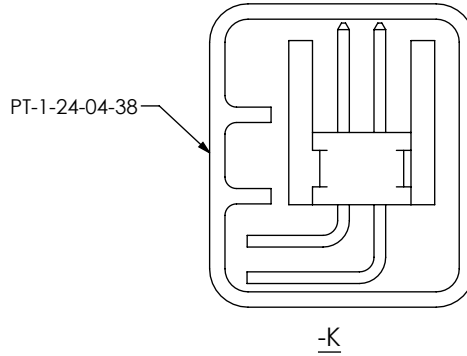
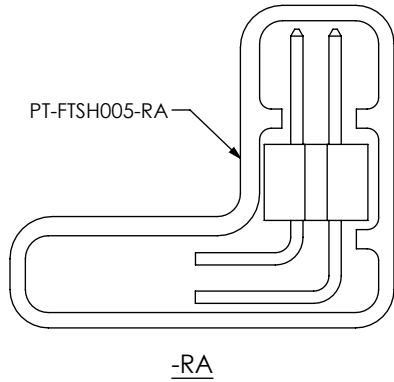

TABLE 4

LEAD STYLE	PACKAGING TUBE	PLUG
-04 (NO OPTIONS)	PT-FTSH005-RA	TP-24
-02, -03, (NO OPTIONS)		
-01-FC		
-01-FE		
-01-RA		
-02-EL, -03-EL	PT-FTSH008-RA-EX	TP-03
-02-ES, -03-ES		
-02-EP, -03-EP		
-01-EJ	PT-1-24-06-40	TR-03
-01-RA-K	PT-1-24-04-38	TP-03

F:\DWG\MISC\MKTG\FTSH-1XX-XX-XX-D-XX-XX-MKT.SLDDRW

PROPRIETARY NOTE
 THIS DOCUMENT CONTAINS INFORMATION CONFIDENTIAL AND PROPRIETARY TO SAMTEC, INC. AND SHALL NOT BE REPRODUCED OR TRANSFERRED TO OTHER DOCUMENTS OR DISCLOSED TO OTHERS OR USED FOR ANY PURPOSE OTHER THAN THAT WHICH IT WAS OBTAINED WITHOUT THE EXPRESSED WRITTEN CONSENT OF SAMTEC, INC.

DO NOT SCALE DRAWING

SHEET SCALE: 2:1



520 PARK EAST BLVD, NEW ALBANY, IN 47150
 PHONE: 812-944-6733 FAX: 812-948-5047
 e-Mail info@SAMTEC.com code 55322

DESCRIPTION:
 .050 x .050 C.L. DOUBLE HORIZONTAL TERMINAL STRIP

DWG. NO.
FTSH-1XX-XX-XX-D-XX-XX

BY: BRATCHER 08/17/1995 SHEET 3 OF 3