

DESIGNED & DIMENSIONED IN MILLIMETERS
(INCHES FOR REFERENCE ONLY)

HDAM-XX-XX.X-X-13-X-X

DO NOT SCALE FROM THIS PRINT

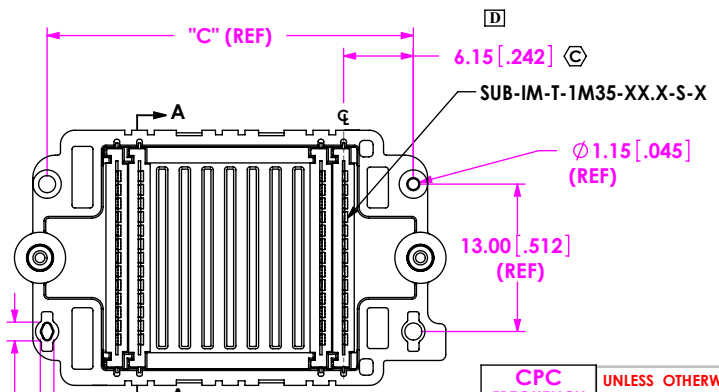
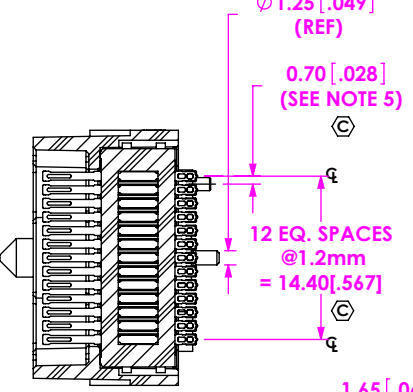
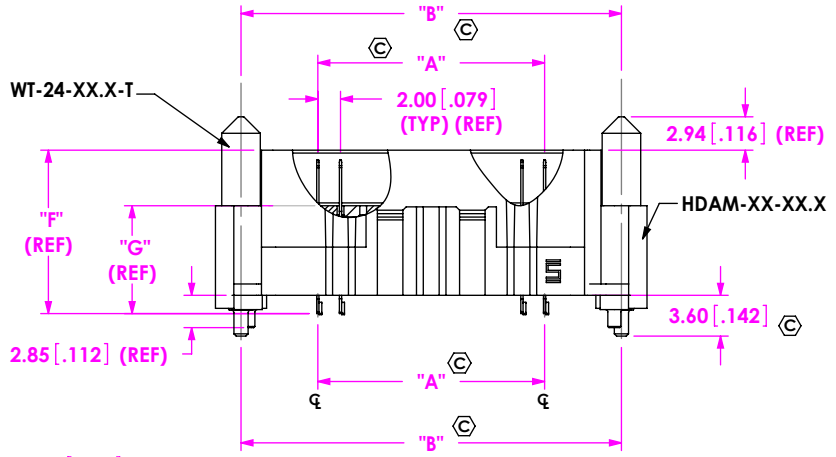
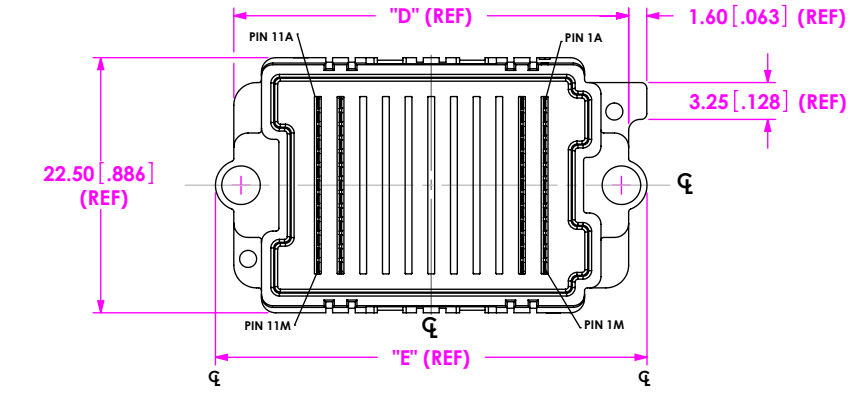

No OF POSITIONS
(13 ROW PER POSITION)
-11
-15
-23

LEAD STYLE
-12.0: 12MM
-17.0: 17MM

PLATING SPECIFICATION
-S: SELECTIVE, .000030 INCHES GOLD IN MATING AREA, MATTE TIN ON TAIL AND GUIDE PINS

OPTION
-P: PICK & PLACE PAD (USE MPP-26-01-N)

SOLDER CHARGE MATERIAL
-1: 63%TIN / 37% LEAD
-2: 95.5% TIN / 3.8% SILVER 0.7% COPPER (LEAD FREE)

No OF ROWS
-13

TABLE 1

STYLE	"BODY CALLOUT"	"TERMINAL WAFER"	"GUIDE PIN"
-12.0	HDAM-XX-12.0	SUB-IM-T-1M35-12.0-S-X	WT-24-12.0-T
-17.0	HDAM-XX-17.0	SUB-IM-T-1M35-17.0-S-X	WT-24-17.0-T

TABLE 2
STACK HEIGHT

HDAM LEAD STYLE	HDAF LEAD STYLE	
	-08.0	-18.0
-12.0	20.0MM	30.0MM
-17.0	25.0MM	35.0MM

TABLE 3

No. OF POS.	LEAD STYLE	"A"	"B"	"C"	"D"	"E"	"F"	"G"
11	12	20.0 [1.787]	33.55 [1.321]	32.30 [1.272]	34.82 [1.371]	38.06 [1.498]	14.41 [1.567]	9.51 [1.374]
15	12	28.0 [1.102]	41.55 [1.636]	40.30 [1.587]	42.82 [1.686]	46.06 [1.813]	14.41 [1.567]	9.51 [1.374]
23	12	44.0 [1.732]	57.55 [2.266]	56.30 [2.217]	58.82 [2.316]	62.06 [2.493]	14.41 [1.567]	9.51 [1.374]
11	17	20.0 [1.787]	33.55 [1.321]	32.30 [1.272]	34.82 [1.371]	38.06 [1.498]	19.41 [1.764]	14.51 [1.571]
15	17	28.0 [1.102]	41.55 [1.636]	40.30 [1.587]	42.82 [1.686]	46.06 [1.813]	19.41 [1.764]	14.51 [1.571]
23	17	44.0 [1.732]	57.55 [2.266]	56.30 [2.217]	58.82 [2.316]	62.06 [2.443]	19.41 [1.764]	14.51 [1.571]

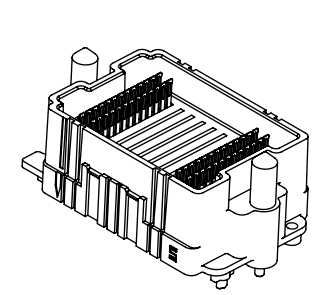

(-12.0 SHOWN)

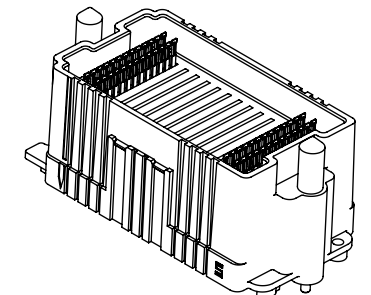

(-17.0 SHOWN)

- NOTES:
1. © REPRESENTS A CRITICAL DIMENSION.
 2. MINIMUM PUSHOUT FORCE: 2.22N[.5 LB]. FOR WAFERS
 3. CONNECTORS TO BE PACKAGED IN TRAYS.
 4. USE THESE SURFACES TO MEASURE "G" DIMENSION.
 5. DIMENSION FROM Ɔ OF END TAIL TO Ɔ OF -A PIN.

FIG 1
-11: 1T POSITION
(HDAM-11-12.0-X-13-X-X SHOWN)
(SOME WAFERS NOT SHOWN FOR CLARITY)

CPC FREQUENCY THIS SHEET

A	C1, C2, C3, C4, C5, C6, C7, C8
B	
C	
D	

UNLESS OTHERWISE SPECIFIED, DIMENSIONS ARE IN MILLIMETERS [INCHES].

TOLERANCES ARE:
DECIMALS ANGLES
X: ±0.3 [0.1]
.XX: ±0.13 [0.05]
.XXX: ±0.051 [0.020]

PROPRIETARY NOTE
THIS DOCUMENT CONTAINS INFORMATION CONFIDENTIAL AND PROPRIETARY TO SAMTEC, INC. AND SHALL NOT BE REPRODUCED OR TRANSFERRED TO OTHER DOCUMENTS OR DISCLOSED TO OTHERS OR USED FOR ANY PURPOSE OTHER THAN THAT WHICH IT WAS OBTAINED WITHOUT THE EXPRESSED WRITTEN CONSENT OF SAMTEC, INC.

MATERIAL: DO NOT SCALE DRAWING SHEET SCALE: 1.5:1

INSULATOR: LCP. COLOR: BLACK
CONTACT: COPPER ALLOY
WAFER MATERIAL: LCP. COLOR: BLACK
GUIDE PIN MATERIAL: BRASS
PICK AND PLACE PAD: COPPER ALLOY

520 PARK EAST BLVD. NEW ALBANY, IN 47150
PHONE: 812-944-6733 FAX: 812-948-5047
e-Mail info@SAMTEC.com code 55322

DESCRIPTION:
2.0MM PITCH HD ARRAY TERMINAL ASSEMBLY

DWG. NO.
HDAM-XX-XX.X-X-13-X-X

BY: D KNOWLDEN 7/15/2005 SHEET 1 OF 2

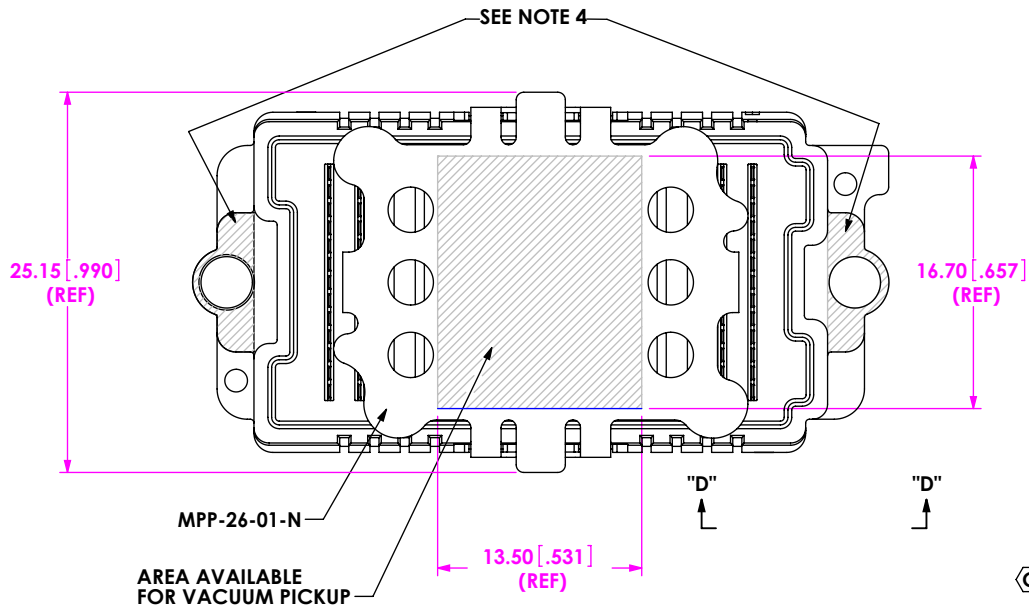
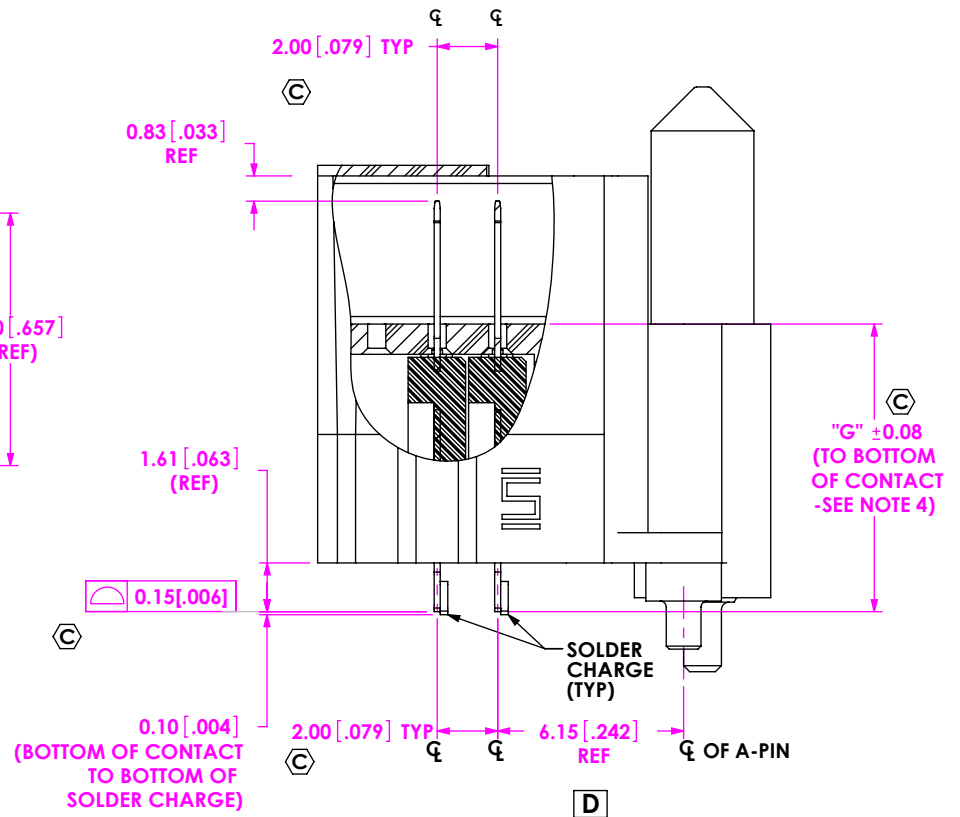
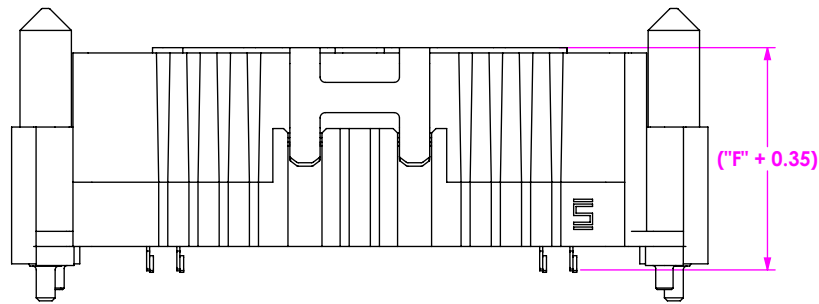

FIG 2
-15: 15 POSITION
(HDAM-15-12.0-X-13-X-P SHOWN)
(SOME WAFERS NOT SHOWN FOR CLARITY)



VIEW D-D
SCALE 4:1

CRITICAL DIMENSION INSPECTION INSTRUCTION TABLE

ASSEMBLY OPERATION	IN-PROCESS INSPECTION
FILL WAFERS	C1, C2, C6, C7, C8, C9, C10, C12, C13
FILL WELD TABS	C3, 10
INSTALL PAD	
FINISHED ASSEMBLY	C13

CPC FREQUENCY THIS SHEET	
A	
B	C13
C	
D	

PROPRIETARY NOTE
THIS DOCUMENT CONTAINS INFORMATION CONFIDENTIAL AND PROPRIETARY TO SAMTEC, INC. AND SHALL NOT BE REPRODUCED OR DISCLOSED TO OTHERS OR USED FOR ANY PURPOSE OTHER THAN THAT WHICH IT WAS OBTAINED WITHOUT THE EXPRESSED WRITTEN CONSENT OF SAMTEC, INC.

DO NOT SCALE DRAWING

SHEET SCALE: 2:1



520 PARK EAST BLVD, NEW ALBANY, IN 47150
PHONE: 812-944-6733 FAX: 812-948-5047
e-Mail info@SAMTEC.com code 55322

DESCRIPTION:
2.0MM PITCH HD ARRAY TERMINAL ASSEMBLY

DWG. NO.
HDAM-XX-XX.X-X-13-X-X

BY:D KNOWLDEN 7/15/2005 SHEET 2 OF 2