

IPS1-1XX-XX-XX-D-RA-XXX

- No OF POS PER ROW  
-02 THRU -25
- LEAD STYLE  
-01
- PLATING SPECIFICATION
- M** -S: SELECTIVE GOLD, MATTE TIN TAILS (USE C-08-XX-S)
  - H: HEAVY GOLD (USE C-08-XX-H)
  - SM: SELECTIVE GOLD, MATTE TIN TAIL (USE C-08-XX-S)
  - M** -L: LIGHT SELECTIVE GOLD, MATTE TIN TAIL (USE C-08-XX-L)
- OPTION
- POL: POSITION #1 REMOVED (USE IPS1-XX-D-P)
  - \* -FL: FRICTION LOCK (USE IPS1-XX-D-FL-X) [POSITIONS -05 THRU -25]
- TAIL OPTION  
-RA: RIGHT ANGLE
- ROW SPECIFICATION  
-D: DOUBLE (USE IPS1-XX-D)
- \* = NOT RELEASED

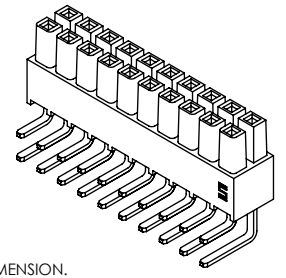
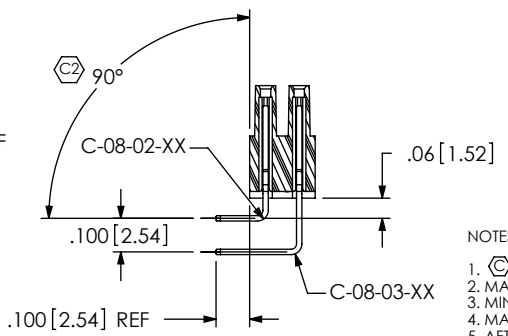
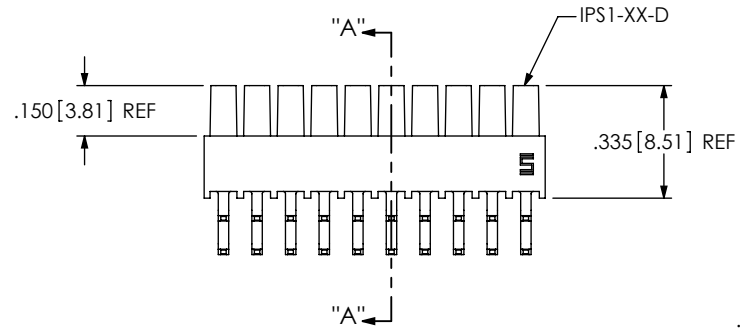

- NOTES:
- $\text{C1}$  REPRESENTS A CRITICAL DIMENSION.
  - MAXIMUM ALLOWABLE CUT FLASH: .010.
  - MINIMUM CONTACT PUSH OUT FORCE: 1.5 lbs.
  - MAXIMUM ALLOWABLE BOW: .003 INCH/INCH AFTER ASSEMBLY.
  - AFTER REVISION N OF COMPONENT IPS1-XX-D-XX-X, SAMTEC LOGO TO APPEAR ON POSITION #1.
  - SAMTEC LOGO INDICATES THE FIRST ROW TO BE FILLED FOR -RA APPLICATION.

SECTION "A"-"A"

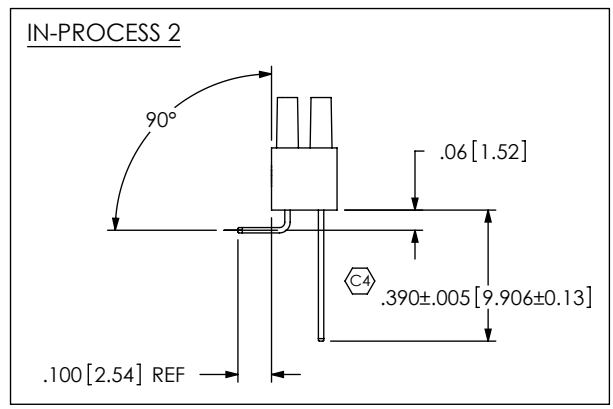
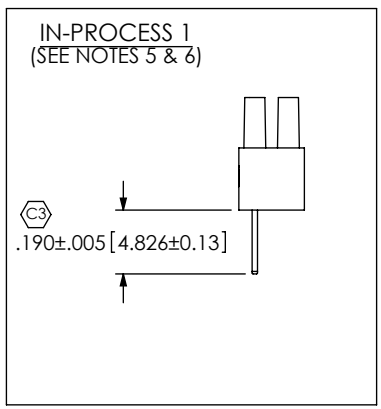

-FL: FRICTION LOCK OPTION  
IPS1-110-01-X-D-RA-FL SHOWN  
\* NOT RELEASED

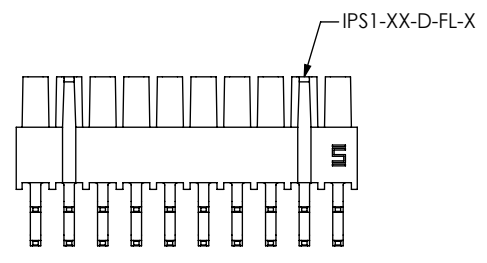

-POL: POLARIZED OPTION  
IPS1-110-01-X-D-RA-POL SHOWN

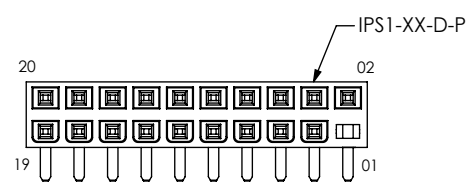

PACKAGING VIEW

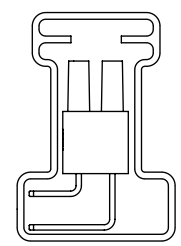

TUBE: PT-1-24-03-44  
PLUG: TP-03

UNLESS OTHERWISE SPECIFIED, DIMENSIONS ARE IN INCHES.  
TOLERANCES ARE:  
DECIMALS ANGLES  
.XX:  $\pm$ .01  $\pm$  2°  
.XXX:  $\pm$ .005  
.XXXX:  $\pm$ .0020

PROPRIETARY NOTE  
THIS DOCUMENT CONTAINS INFORMATION CONFIDENTIAL AND PROPRIETARY TO SAMTEC, INC. AND SHALL NOT BE REPRODUCED OR TRANSFERRED TO OTHER DOCUMENTS OR DISCLOSED TO OTHERS OR USED FOR ANY PURPOSE OTHER THAN THAT WHICH IT WAS OBTAINED WITHOUT THE EXPRESSED WRITTEN CONSENT OF SAMTEC, INC.

520 PARK EAST BLVD, NEW ALBANY, IN 47150  
PHONE: 812-944-6733 FAX: 812-948-5047  
e-Mail: info@SAMTEC.com code: 55322

MATERIAL: DO NOT SCALE DRAWING SHEET SCALE: 1.75:1  
INSULATOR: VECTRA E130i, COLOR: BLACK  
CONTACT: PHOS BRONZE, 510 SPRING TEMPER

DESCRIPTION:  
.100 DOUBLE ROW SHROUDED SOCKET ASSEMBLY  
DWG. NO.  
IPS1-1XX-XX-XX-D-RA-XXX