

DO NOT SCALE FROM THIS PRINT

QMS-XXX-XX-XX-D-RA-XX-XXX-XX

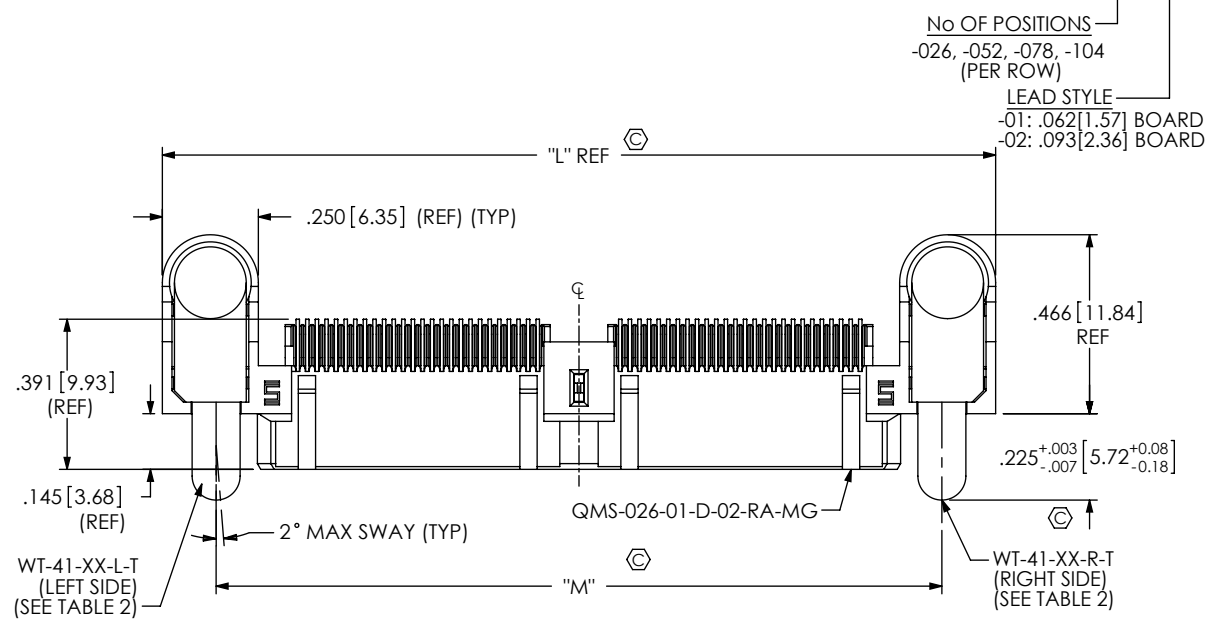

- PACKAGING OPTION
 - TR: TAPE & REEL PACKAGING (-026 & -052 WITH NO OPTIONS)
 - (-026 & -052 WITH -PC4)
 - (-026 WITH -PC8)
- OPTION
 - K: KAPTON PAD (USE K-850-650)
 - PC4: 4 POWER PINS (SEE FIG. 2, SHEET 5) (NOT AVAILABLE WITH -104 POS) (NOT AVAILABLE WITH -MG)
 - PC8: 8 POWER PINS (SEE FIG. 3, SHEET 5) (NOT AVAILABLE WITH -104 POS) (NOT AVAILABLE WITH -MG)
- GUIDE POST
 - MG: METAL GUIDE POST (LEAVE BLANK FOR PLASTIC OR PCX. PLASTIC AVAILABLE AS ASO ONLY.)
- RA: RIGHT ANGLE
- ROW SPECIFICATION
 - D: DOUBLE (USE QMS-XXX-01-D-XX-RA)
- PLATING SPECIFICATION (SEE TABLE 6, SHEET 4)
 - SL: 10μ" GOLD IN CONTACT AREA, MATTE TIN TAIL
 - S: 30μ" GOLD IN CONTACT AREA, MATTE TIN TAIL
 - L: 10μ" GOLD IN CONTACT AREA, 3μ" GOLD ON TAIL
 - H: 30μ" GOLD IN CONTACT AREA, 3μ" GOLD ON TAIL

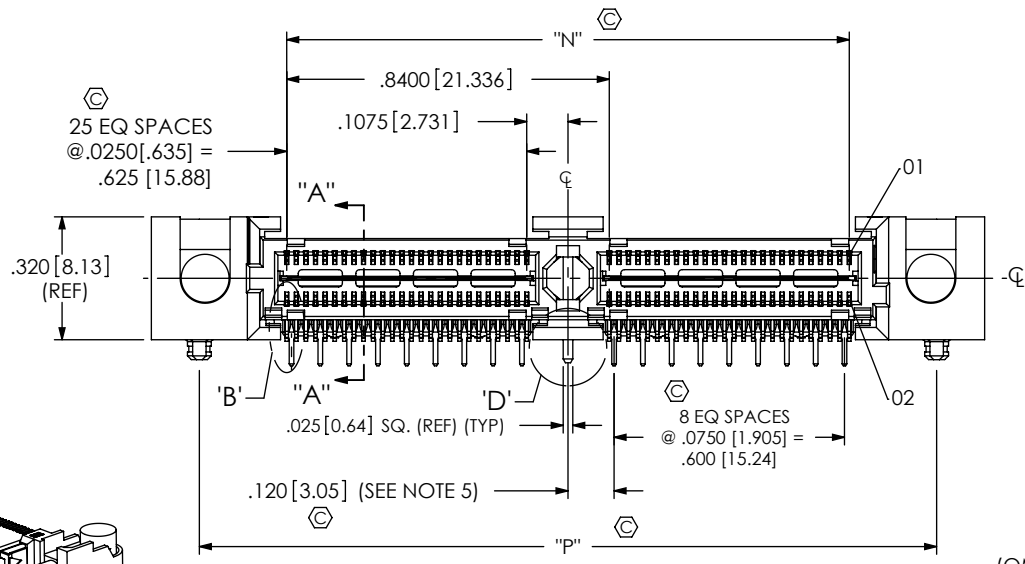
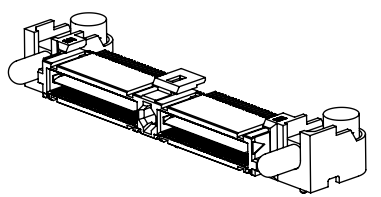

TABLE 5

POSITION	"L"	"M"	"N"	"P"
-026	1.330 [33.78]	1.050 [26.67]	.625 [15.88]	1.080 [27.43]
-052	2.170 [55.12]	1.890 [48.01]	1.465 [37.21]	1.920 [48.77]
-078	3.010 [76.45]	2.730 [69.34]	2.305 [58.55]	2.760 [70.10]
-104	3.850 [97.79]	3.570 [90.68]	3.145 [79.88]	3.600 [91.44]

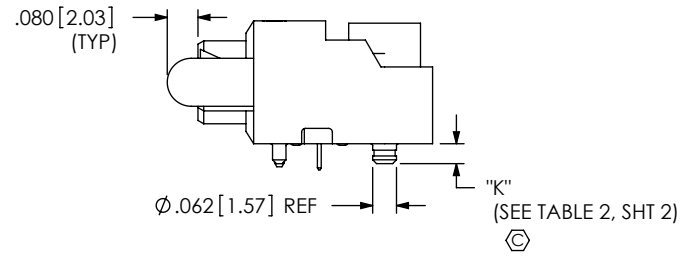

FIG. 1 (QMS-052-XX-XX-D-RA-MG SHOWN)

- NOTES:
- REPRESENTS A CRITICAL DIMENSION.
 - MAXIMUM BURR ALLOWANCE: .0010 [0.02]
 - MINIMUM PUSHOUT FORCE: SIGNAL: .5 LB. [2.22N] SHIELD/GROUND, POWER PIN, COUNTERWEIGHT AND METAL GUIDE POST: 1 LB. [4.45N]
 - PARTS TO BE PACKAGED IN TRAYS AS STANDARD.
 - DOES NOT APPLY TO 1 BANK.
 - WT-28-XX-T NOT PRESENT ON SINGLE BANK WITH THE -MG OPTION
 - USE -Z- DATUM ZONE ONLY FOR MEASUREMENTS.

UNLESS OTHERWISE SPECIFIED, DIMENSIONS ARE IN INCHES. TOLERANCES ARE: DECIMALS ANGLES .XX: ±.01 [.3] 2° .XXX: ±.005 [.13] .XXXX: ±.0020 [.051]	PROPRIETARY NOTE THIS DOCUMENT CONTAINS INFORMATION CONFIDENTIAL AND PROPRIETARY TO SAMTEC, INC. AND SHALL NOT BE REPRODUCED OR TRANSFERRED TO OTHER DOCUMENTS OR DISCLOSED TO OTHERS OR USED FOR ANY PURPOSE OTHER THAN THAT WHICH IT WAS OBTAINED WITHOUT THE EXPRESSED WRITTEN CONSENT OF SAMTEC, INC.		
		520 PARK EAST BLVD. NEW ALBANY, IN 47150 PHONE: 812-944-6733 FAX: 812-948-5047 e-Mail: info@SAMTEC.com code 55322	
MATERIAL: DO NOT SCALE DRAWING SHEET SCALE: 2:1 INSULATOR: LCP, COLOR BLACK CONTACT, POWER PIN, & GROUND PLANE: PHOS BRONZE COUNTERWEIGHT: BRASS METAL GUIDE POST: ZINC	DESCRIPTION: .635mm DUAL ROW RIGHT ANGLE PLUG ASSEMBLY DWG. NO. QMS-XXX-XX-XX-D-RA-XX-XXX-XX		
	BY: KNOWLDEN 8/25/2006 SHEET 1 OF 6		

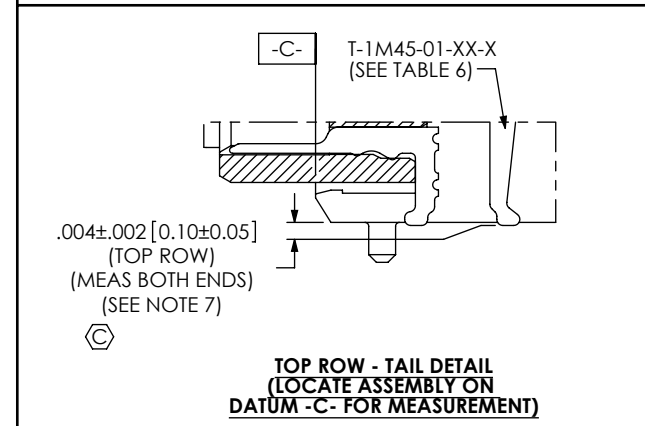
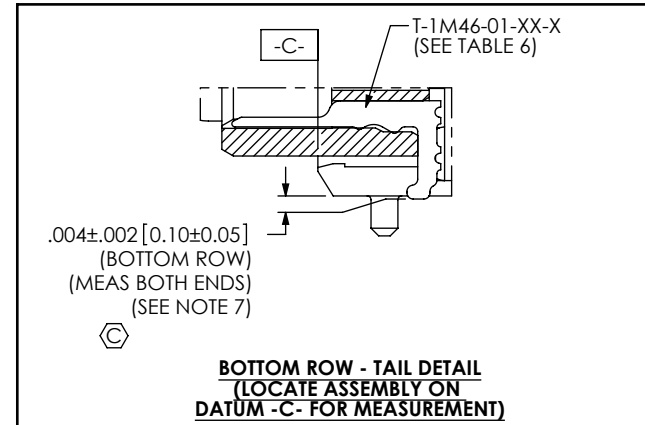
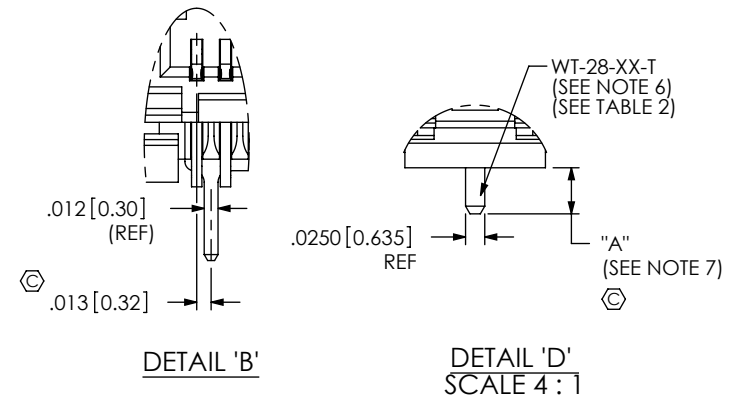
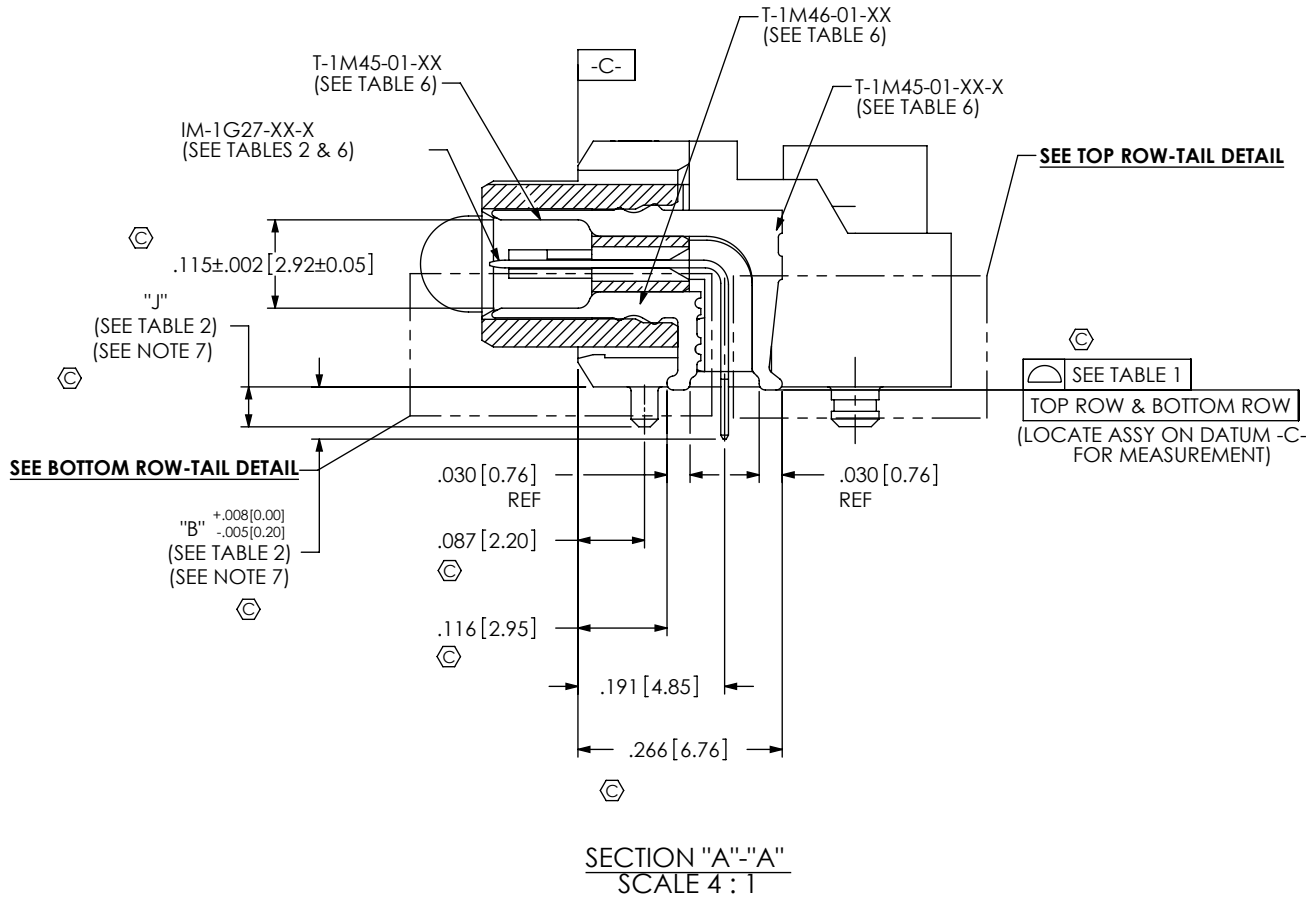

TABLE 1

No OF POSITIONS	COPLANARITY	STRAIGHTNESS ROW 1	STRAIGHTNESS ROW 2
-026 THRU -052	.004[.10]	.004[.10]	.004[.10]
-078 THRU -104	.006[.15]	.006[.15]	.006[.15]

TABLE 2

LEAD STYLE	"A"	"B"	"C"	"J"	"K"	WT-28-XX-T	IM-1G27-XX-L	T-1R37-XX-T	WT-41-XX-X-T
-01	.060 [1.52]	.068 [1.73]	.055 [1.40]	.052 [1.32]	.052 [1.32]	WT-28-01-T	IM-1G27-01-L	T-1R37-01-T	WT-41-01-X-T
-02	.091 [2.31]	.099 [2.51]	.086 [2.18]	.083 [2.11]	.083 [2.11]	WT-28-02-T	IM-1G27-02-L	T-1R37-02-T	WT-41-02-X-T

PROPRIETARY NOTE
THIS DOCUMENT CONTAINS INFORMATION CONFIDENTIAL AND PROPRIETARY TO SAMTEC, INC. AND SHALL NOT BE REPRODUCED OR TRANSFERRED TO OTHER DOCUMENTS OR DISCLOSED TO OTHERS OR USED FOR ANY PURPOSE OTHER THAN THAT WHICH IT WAS OBTAINED WITHOUT THE EXPRESSED WRITTEN CONSENT OF SAMTEC, INC.

DO NOT SCALE DRAWING
SHEET SCALE: 1:0.166667

520 PARK EAST BLVD, NEW ALBANY, IN 47150
PHONE: 812-944-6733 FAX: 812-948-5047
e-Mail: info@SAMTEC.com code 55322

DESCRIPTION:
.635mm DUAL ROW RIGHT ANGLE PLUG ASSEMBLY
DWG. NO.
QMS-XXX-XX-XX-D-RA-XX-XXX-XX
BY: KNOWLDEN 8/25/2006 SHEET 2 OF 6

INSPECTION VIEW 1
(FILL BOTTOM ROW)

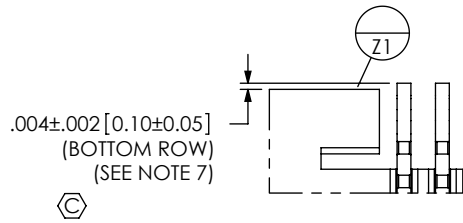
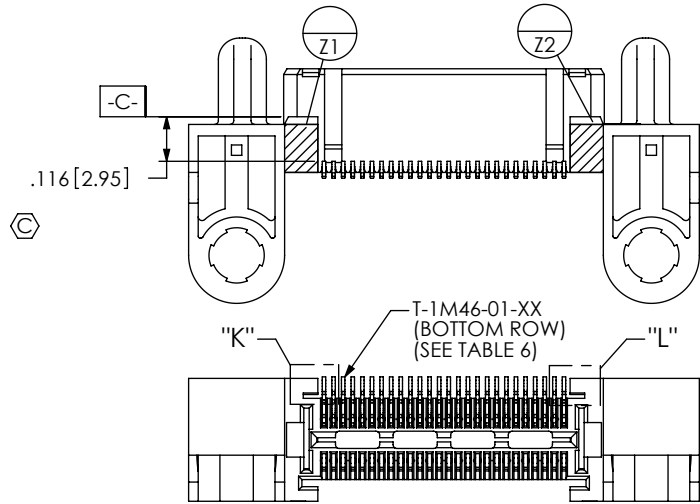

DETAIL "K"
SCALE 8 : 1

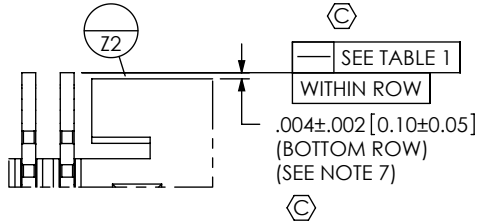

DETAIL "L"
SCALE 8 : 1

INSPECTION VIEW 2
(FILL IM-1G27)

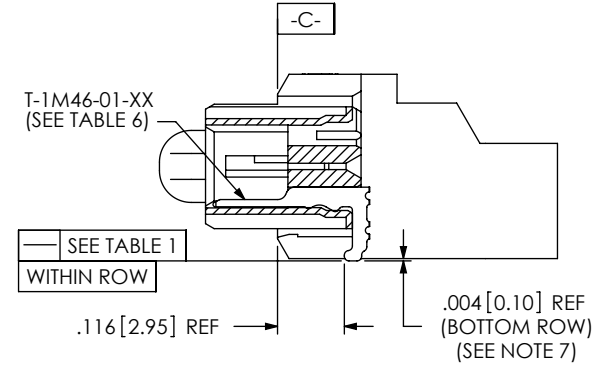
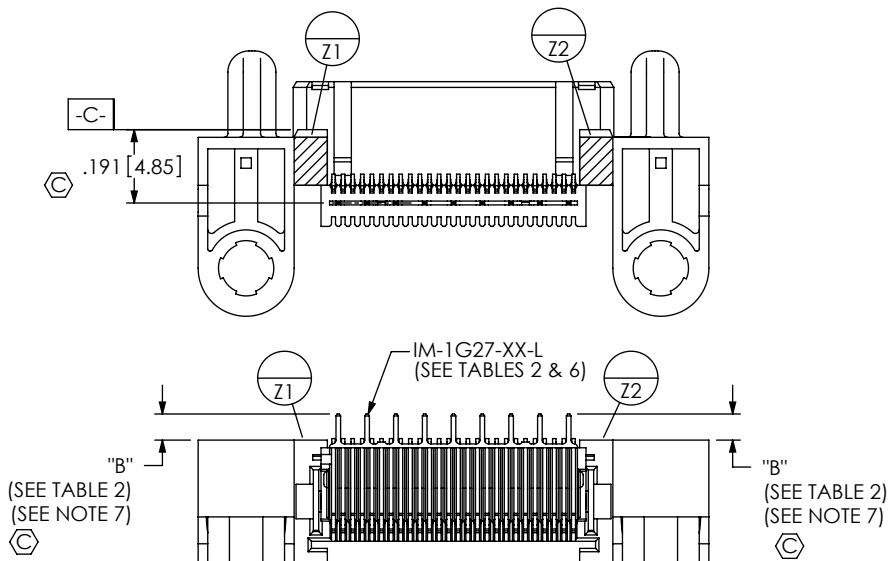

IN-PROCESS 1
(FILL BOTTOM ROW)
(SEE INSPECTION VIEW 1 FOR ORIENTATION AND CPC'S)

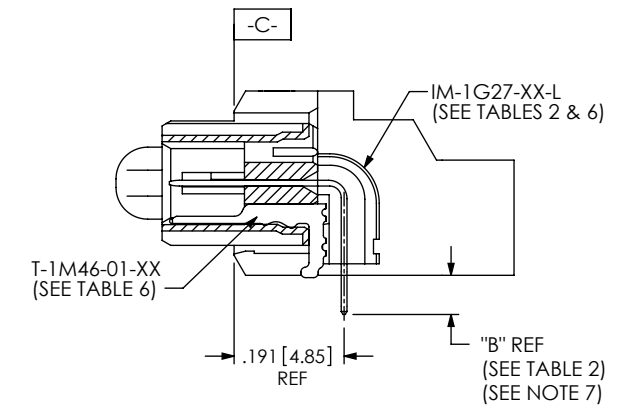

IN-PROCESS 2
(FILL IM-1G27)
(SEE INSPECTION VIEW 2 FOR ORIENTATION AND CPC'S)

PROPRIETARY NOTE
THIS DOCUMENT CONTAINS INFORMATION CONFIDENTIAL AND PROPRIETARY TO SAMTEC, INC. AND SHALL NOT BE REPRODUCED OR TRANSFERRED TO OTHER DOCUMENTS OR DISCLOSED TO OTHERS OR USED FOR ANY PURPOSE OTHER THAN THAT WHICH IT WAS OBTAINED WITHOUT THE EXPRESSED WRITTEN CONSENT OF SAMTEC, INC.

DO NOT SCALE DRAWING

SHEET SCALE: 1:0.166667



520 PARK EAST BLVD, NEW ALBANY, IN 47150
PHONE: 812-944-6733 FAX: 812-948-5047
e-Mail: info@SAMTEC.com code 55322

DESCRIPTION:
.635mm DUAL ROW RIGHT ANGLE PLUG ASSEMBLY

DWG. NO.
QMS-XXX-XX-XX-D-RA-XX-XXX-XX

BY: KNOWLDEN 8/25/2006 SHEET 3 OF 6

INSPECTION VIEW 3
(FILL TOP ROW)

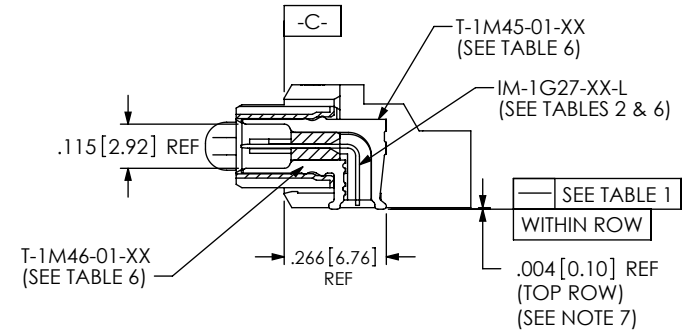
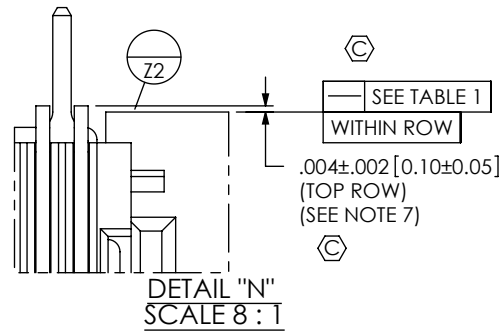
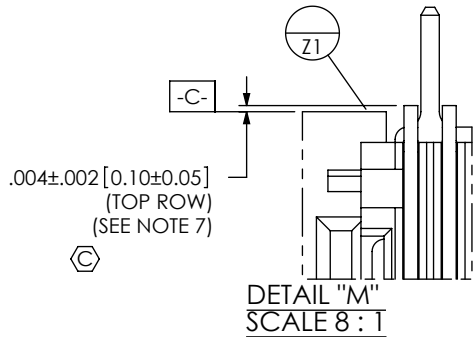
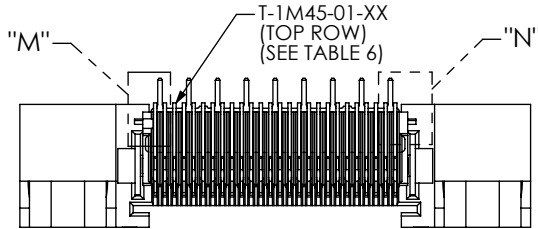
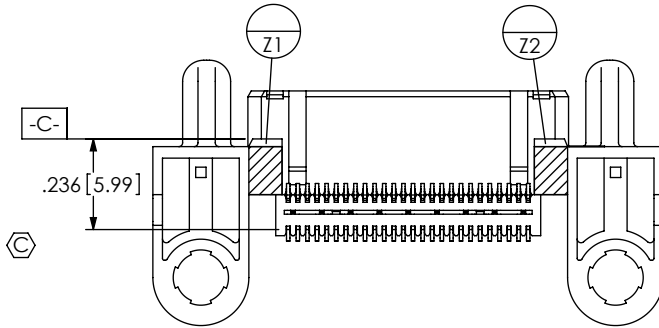
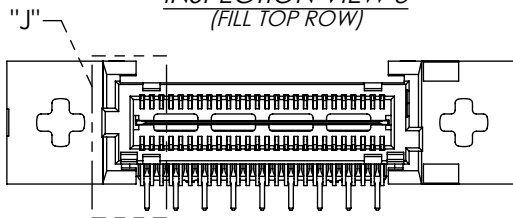

IN-PROCESS 3
(FILL TOP ROW)
(SEE INSPECTION VIEW 3 FOR ORIENTATION AND CPC'S)

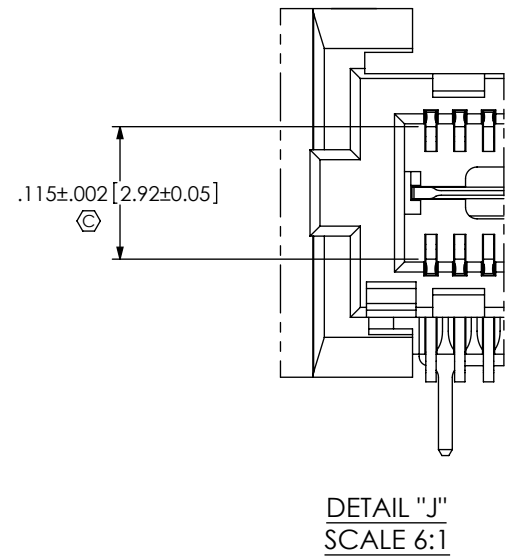

TABLE 6: PLATING SPECIFICATIONS

	CONTACT	CONTACT	GROUND PLANE	PCX CONTACTS
-SL	T-1M45-01-SL: 10µ" GOLD CONTACT, MATTE TIN TAIL	T-1M46-01-SL: 10µ" GOLD CONTACT, MATTE TIN TAIL	IM-1G27-XX-L: 10µ" GOLD CONTACT, MATTE TIN TAIL	T-1S69-XX-SL: 10µ" GOLD CONTACT, MATTE TIN TAIL
-S	T-1M45-01-S: 30µ" GOLD CONTACT, MATTE TIN TAIL	T-1M46-01-S: 30µ" GOLD CONTACT, MATTE TIN TAIL	IM-1G27-XX-L: 10µ" GOLD CONTACT, MATTE TIN TAIL	T-1S69-XX-S: 30µ" GOLD CONTACT, MATTE TIN TAIL
-L	T-1M45-01-L: 10µ" GOLD CONTACT, 3µ" GOLD TAIL	T-1M46-01-L: 10µ" GOLD CONTACT, 3µ" GOLD TAIL	IM-1G27-XX-L: 10µ" GOLD CONTACT, MATTE TIN TAIL	T-1S69-XX-SL: 10µ" GOLD CONTACT, MATTE TIN TAIL
-H	T-1M45-01-H: 30µ" GOLD CONTACT, 3µ" GOLD TAIL	T-1M46-01-H: 30µ" GOLD CONTACT, 3µ" GOLD TAIL	IM-1G27-XX-L: 10µ" GOLD CONTACT, MATTE TIN TAIL	T-1S69-XX-S: 30µ" GOLD CONTACT, MATTE TIN TAIL

PROPRIETARY NOTE

THIS DOCUMENT CONTAINS INFORMATION CONFIDENTIAL AND PROPRIETARY TO SAMTEC, INC. AND SHALL NOT BE REPRODUCED OR TRANSFERRED TO OTHER DOCUMENTS OR DISCLOSED TO OTHERS OR USED FOR ANY PURPOSE OTHER THAN THAT WHICH IT WAS OBTAINED WITHOUT THE EXPRESSED WRITTEN CONSENT OF SAMTEC, INC.

DO NOT SCALE DRAWING

SHEET SCALE: 1:0.166667



520 PARK EAST BLVD, NEW ALBANY, IN 47150
PHONE: 812-944-6733 FAX: 812-948-5047
e-Mail: info@SAMTEC.com code 55322

DESCRIPTION:
.635mm DUAL ROW RIGHT ANGLE PLUG ASSEMBLY

DWG. NO.
QMS-XXX-XX-XX-D-RA-XX-XXX-XX

BY: KNOWLDEN 8/25/2006 SHEET 4 OF 6

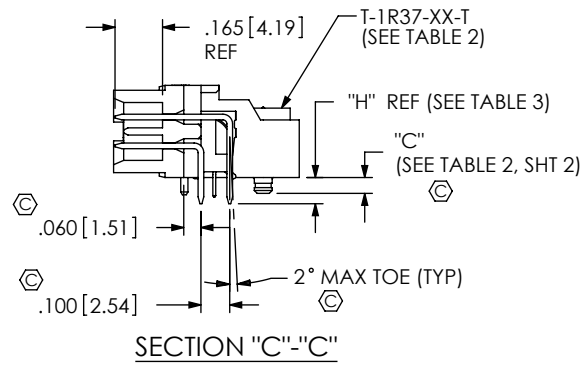
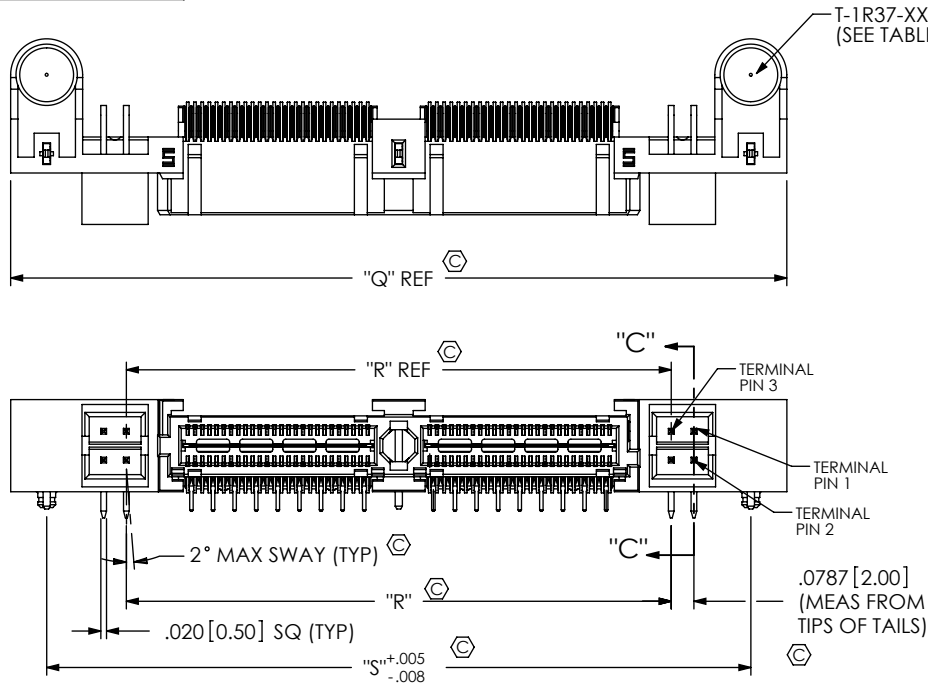
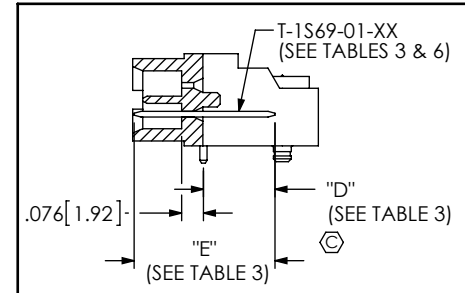
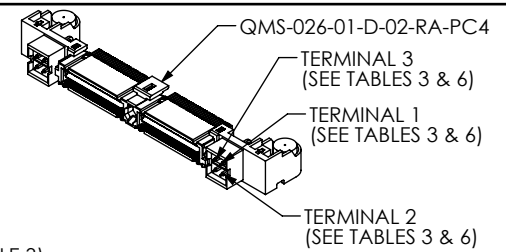
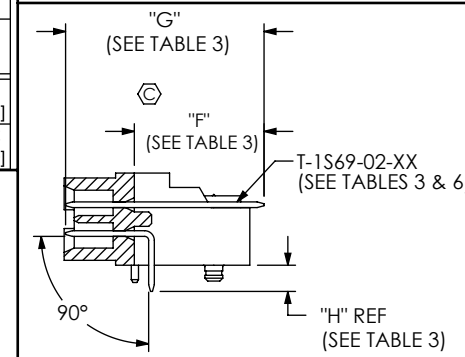

FIG 2
(QMS-052-XX-XX-D-RA-PC4 SHOWN)
(SAME AS FIG 1, DIFFERENT AS SHOWN)

LEAD STYLE	TERMINAL 1	TERMINAL 2	"D"	"E"	"F"	"G"	"H"
-01	T-1S69-01-XX	T-1S69-02-XX	.248 [6.30]	.489 [12.42]	.450 [11.43]	.689 [17.50]	.091 [2.31]
-02	T-1S69-03-XX	T-1S69-04-XX	.279 [7.09]	.520 [13.21]	.481 [12.22]	.720 [18.29]	.122 [3.10]



IN-PROCESS 4



IN-PROCESS 5

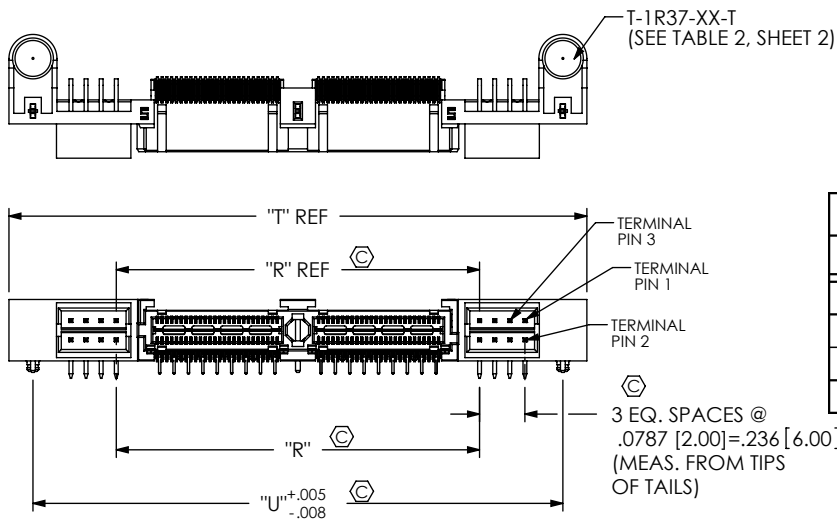
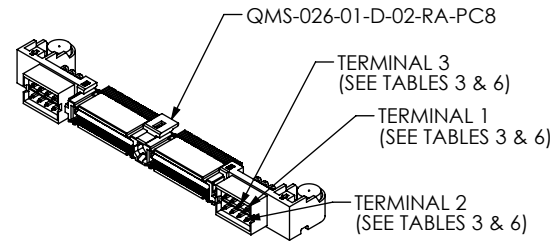

FIG 3
(QMS-052-XX-XX-D-RA-PC8 SHOWN)
(SAME AS FIG 2, DIFFERENT AS SHOWN)



POSITION	"Q"	"R"	"S"	"T"	"U"	"V"	"W"
-026	1.855 [47.12]	1.052 [26.72]	1.605 [40.77]	2.170 [55.12]	1.920 [48.77]	1.050 [26.67]	1.080 [27.43]
-052	2.695 [68.45]	1.892 [48.06]	2.445 [62.10]	3.010 [76.45]	2.760 [70.10]	1.890 [48.01]	1.920 [48.77]
-078	3.535 [89.79]	2.732 [69.39]	3.285 [83.44]	3.850 [97.79]	3.600 [91.44]	2.730 [69.34]	2.760 [70.10]
-104	4.375 [111.13]	3.572 [90.73]	4.125 [104.78]	4.690 [119.13]	4.440 [112.78]	3.570 [90.68]	3.600 [91.44]

PROPRIETARY NOTE
THIS DOCUMENT CONTAINS INFORMATION
CONFIDENTIAL AND PROPRIETARY TO
SAMTEC, INC. AND SHALL NOT BE REPRODUCED
OR TRANSFERRED TO OTHER DOCUMENTS OR
DISCLOSED TO OTHERS OR USED FOR ANY
PURPOSE OTHER THAN THAT WHICH IT WAS
OBTAINED WITHOUT THE EXPRESSED WRITTEN
CONSENT OF SAMTEC, INC.

DO NOT SCALE DRAWING

SHEET SCALE: 1.5:1



520 PARK EAST BLVD, NEW ALBANY, IN 47150
PHONE: 812-944-6733 FAX: 812-948-5047
e-Mail info@SAMTEC.com code 55322

DESCRIPTION:
.635mm DUAL ROW RIGHT ANGLE PLUG ASSEMBLY

DWG. NO.
QMS-XXX-XX-XX-D-RA-XX-XXX-XX

BY: KNOWLDEN 8/25/2006 SHEET 5 OF 6

REVISION Z

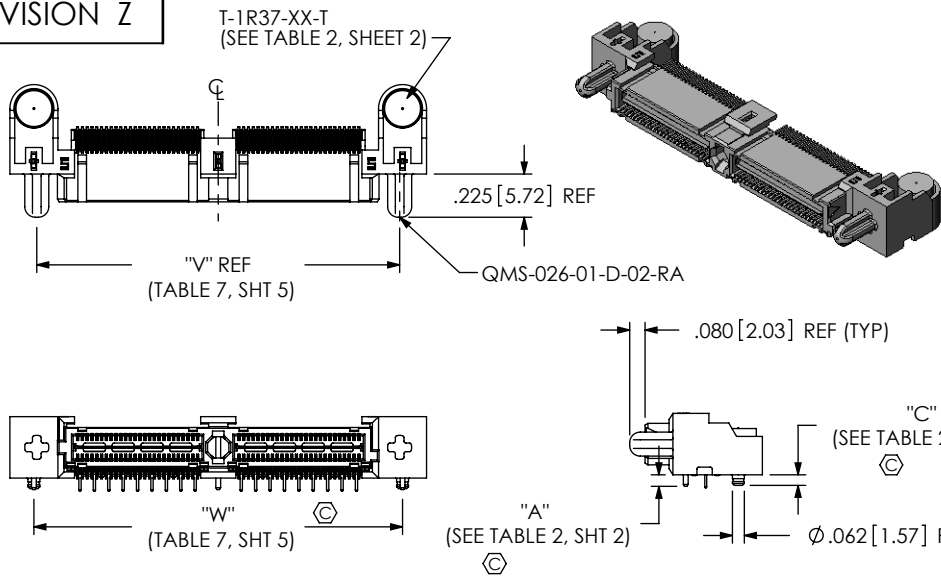
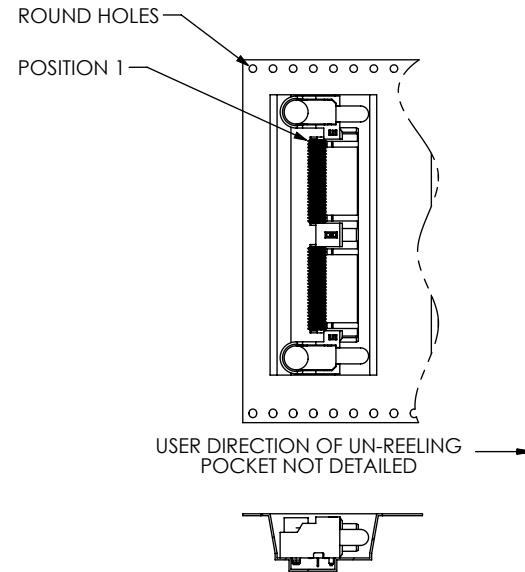

FIG 4
(QMS-052-01-XX-D-RA SHOWN)
(SAME AS FIG 1, DIFFERENT AS SHOWN)
AVAILABLE AS ASO ONLY

PACKAGING VIEW
-TR: TAPE & REEL OPTION
(QMS-052-01-XX-D-RA-MG-TR SHOWN)



-K: KAPTON PAD
QMS-026-01-XX-D-RA-MG-K SHOWN
(USE K-850-650)
(FOR 1 AND 3 BANKS ONLY)

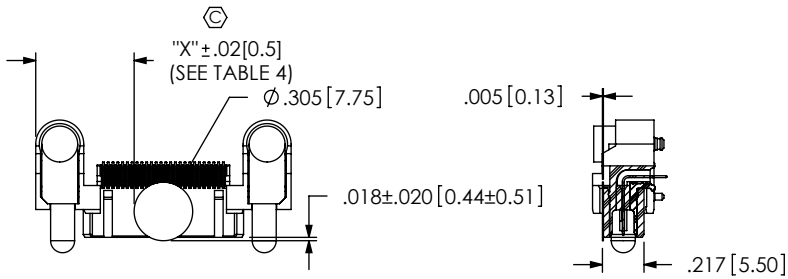
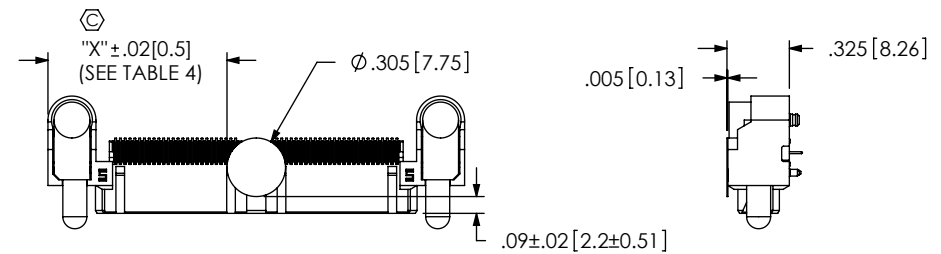

TABLE 4			
	STANDARD & -MG	-PC4	-PC8
POS.	"X"		
-026	0.513 [13.03]	0.776 [19.71]	0.934 [23.71]
-052	0.933 [23.70]	1.196 [30.38]	1.354 [34.38]
-078	1.353 [34.37]	1.616 [41.05]	1.774 [45.05]
-104	1.773 [45.03]	2.036 [51.71]	2.194 [55.71]

-K: KAPTON PAD
QMS-052-01-XX-D-RA-MG-K SHOWN
(USE K-850-650)
(FOR 2 AND 4 BANKS ONLY)



PROPRIETARY NOTE
THIS DOCUMENT CONTAINS INFORMATION
CONFIDENTIAL AND PROPRIETARY TO
SAMTEC, INC. AND SHALL NOT BE REPRODUCED
OR TRANSFERRED TO OTHER DOCUMENTS OR
DISCLOSED TO OTHERS OR USED FOR ANY
PURPOSE OTHER THAN THAT WHICH IT WAS
OBTAINED WITHOUT THE EXPRESSED WRITTEN
CONSENT OF SAMTEC, INC.

DO NOT SCALE DRAWING
SHEET SCALE: 1:1



520 PARK EAST BLVD, NEW ALBANY, IN 47150
PHONE: 812-944-6733 FAX: 812-948-5047
e-Mail: info@SAMTEC.com code 55322

DESCRIPTION:
.635mm DUAL ROW RIGHT ANGLE PLUG ASSEMBLY

DWG. NO.
QMS-XXX-XX-XX-D-RA-XX-XXX-XX

BY: KNOWLDEN 8/25/2006 SHEET 6 OF 6