

DO NOT SCALE FROM THIS PRINT

QFSS-XXX-XX.XX-X-D-X-XXX-XX

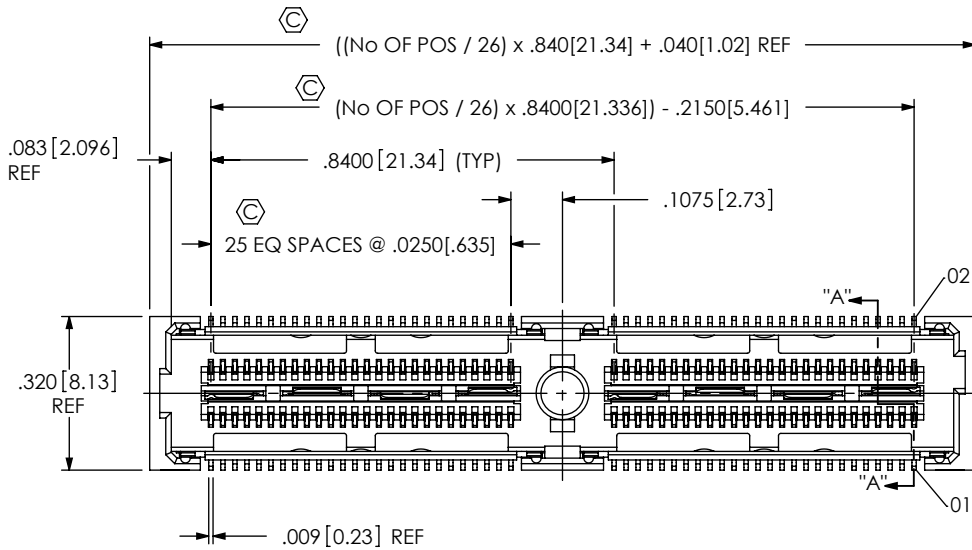

No OF POSITIONS
 -026, -052, -078, -104, * -130 (PER ROW)

LEAD STYLE
 -04.25 (SEE NOTE 10)

PLATING SPECIFICATION
 -L: LIGHT GOLD (USE C-181-04.25-L)
 -H: HEAVY GOLD (USE C-181-04.25-H)
 (ALL PLATING STYLES USE SH2-01-L & T-1G20-04.25-L)

ROW SPECIFICATION
 -D: DOUBLE

* = NOT TOOLED

PACKAGING OPTION
 -TR: TAPE & REEL PACKAGING (-026 THRU -078 WITHOUT OPTIONS)
 -GP OR -PXX, -026 THRU -052 WITH OPTIONS-GP OR -PXX

OPTION
 -BM: BLIND MATE SHIELD (USE ASP-126355-02-P-L)
 -GP: GUIDE HOLES (SEE FIG 2, SHEET 2) [NOT AVAILABLE WITH -PXX]
 -PC4: 4 POWER POS PER END (.062" THICK BOARD) (SEE FIG 3, SHEET 3) (USE C-79-06-S)
 -PC8: 8 POWER POS PER END (.062" THICK BOARD) (SEE FIG 3, SHEET 3) (USE C-79-06-S)
 -PT4: 4 POWER POS PER END (.093" THICK BOARD) (SEE FIG 3, SHEET 3) (USE C-79-09-S)
 -PT8: 8 POWER POS PER END (.093" THICK BOARD) (SEE FIG 3, SHEET 3) (USE C-79-09-S)
 -P: PICK & PLACE PAD (USE PPP-51, SEE FIG 4, SHEET 4)
[-PXX NOT AVAILABLE WITH -GP]
[-PXX AVAILABLE ON POSITIONS -026, -052 & -078 ONLY]

OPTION
 -A: ALIGNMENT PIN [NOT AVAILABLE WITH -PXX]

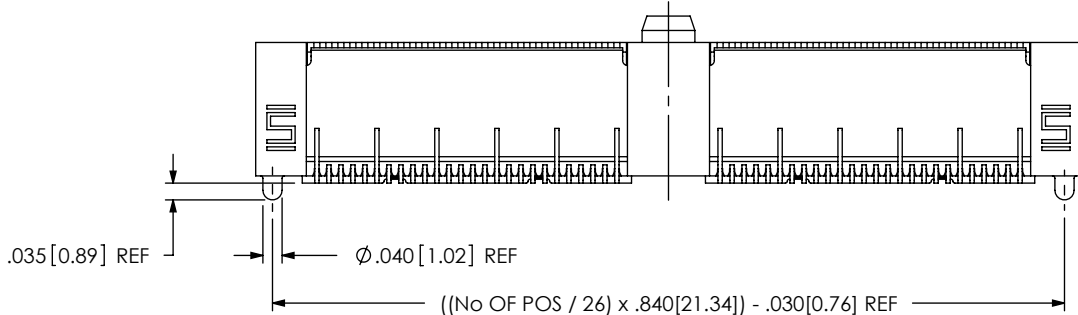
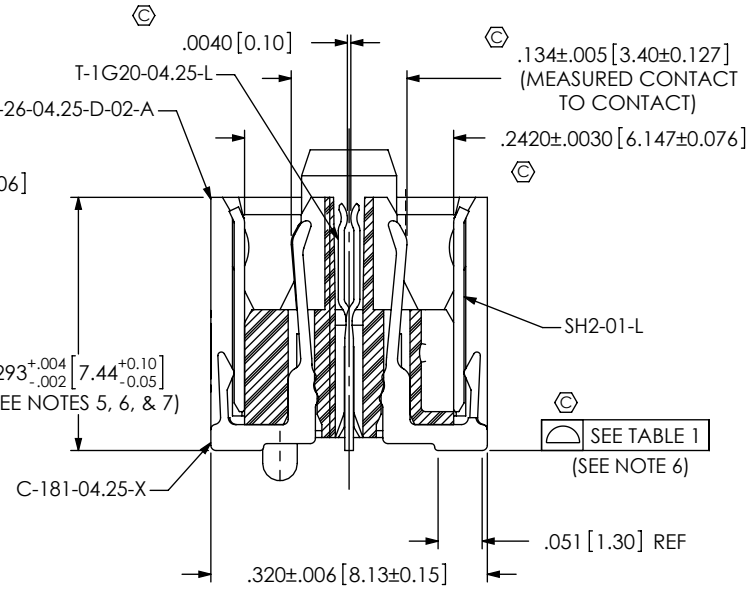
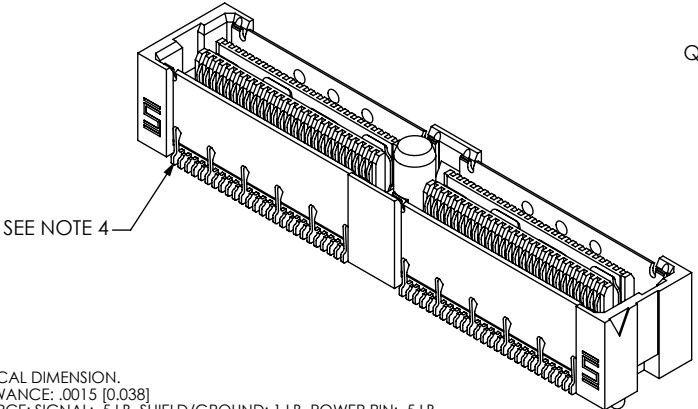

FIG 1
 QFSS-052-04.25-X-D-A SHOWN



SECTION "A"- "A"
 SCALE 4.5 : 1

TABLE 1		
No OF POSITIONS	No OF BANKS	COPLANARITY
-026 THRU -078	1 THRU 3	.004 [.10]
-104 AND -130	4 AND 5	.006 [.15]



NOTES:

1. \odot REPRESENTS A CRITICAL DIMENSION.
2. MAXIMUM BURR ALLOWANCE: .0015 [0.038]
3. MINIMUM PUSHOUT FORCE: SIGNAL: .5 LB, SHIELD/GROUND: 1 LB, POWER PIN: .5 LB.
4. TERMINALS IN THE FIRST ROW OF EACH BANK AND EVERY FIFTH ROW AFTER THAT WILL NOT BE SHEARED.
5. MAXIMUM VARIANCE: .002 [0.05].
6. DIMENSION APPLIES TO CONTACTS & GROUND PLANE.
7. GROUND PLANE PRESS HEIGHT MUST BE .003 [.08] LESS THAN THE MAX HEIGHT OR .001 [.03] GREATER THAN THE MINIMUM HEIGHT OF THE TERMINAL.
8. DISREGARD ANY BREAK-OFF BURRS FOR THIS DIMENSION.
9. PARTS TO BE PACKAGED IN TRAYS AS STANDARD
10. LEADSTYLE -01 MAY BE SUBSTITUTED IN PART CALLOUT FOR -04.25 FOR EXISTING CUSTOMERS ONLY

PATENT NUMBERS
 6739884/ 7165994
 7121849

UNLESS OTHERWISE SPECIFIED, DIMENSIONS ARE IN INCHES. TOLERANCES ARE:
 DECIMALS ANGLES
 .XX: ±.01 [.3] 2°
 .XXX: ±.005 [.13]
 .XXXX: ±.0020 [.051]

PROPRIETARY NOTE
 THIS DOCUMENT CONTAINS INFORMATION CONFIDENTIAL AND PROPRIETARY TO SAMTEC, INC. AND SHALL NOT BE REPRODUCED OR TRANSFERRED TO OTHER DOCUMENTS OR DISCLOSED TO OTHERS OR USED FOR ANY PURPOSE OTHER THAN THAT WHICH IT WAS OBTAINED WITHOUT THE EXPRESSED WRITTEN CONSENT OF SAMTEC, INC.

520 PARK EAST BLVD. NEW ALBANY, IN 47150
 PHONE: 812-944-6733 FAX: 812-948-5047
 e-Mail: info@SAMTEC.com code: 55322

MATERIAL: DO NOT SCALE DRAWING SHEET SCALE: 2.5:1
 INSULATOR: VECTRA E130, COLOR: BLACK
 TERMINAL, GROUND PLANE, & SHIELD: PHOS BRONZE:

DESCRIPTION:
 .635mm DOUBLE ROW SHIELDED TERMINAL STRIP
 DWG. NO.
QFSS-XXX-XX.XX-X-D-X-XXX-XX

IN-PROCESS 1

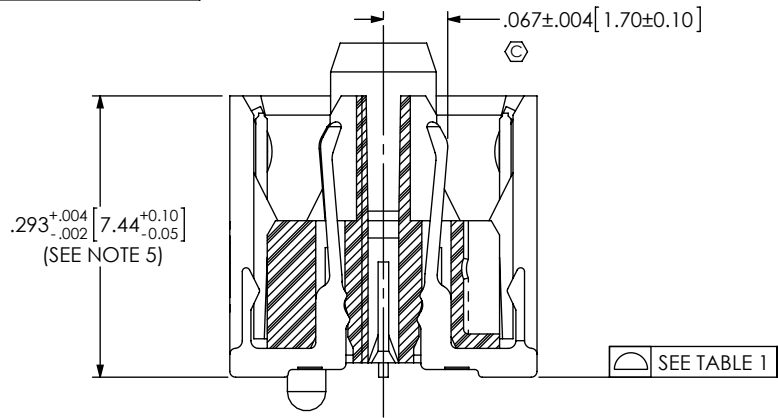

CONTACT DETAILS

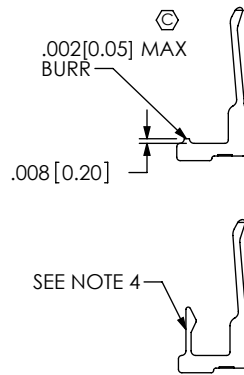

TABLE 2

ASSEMBLY	"A"	"B"
QFSS-026-04.25-X-D-A-GP	1.050[26.67]	1.330[33.78]
QFSS-052-04.25-X-D-A-GP	1.890[48.00]	2.170[55.12]
QFSS-078-04.25-X-D-A-GP	2.730[69.34]	3.010[76.45]
QFSS-104-04.25-X-D-A-GP	3.570[90.68]	3.850[97.79]
* QFSS-130-04.25-X-D-A-GP	4.410[112.01]	4.690[119.13]

* NOT TOOLED

IN-PROCESS 2

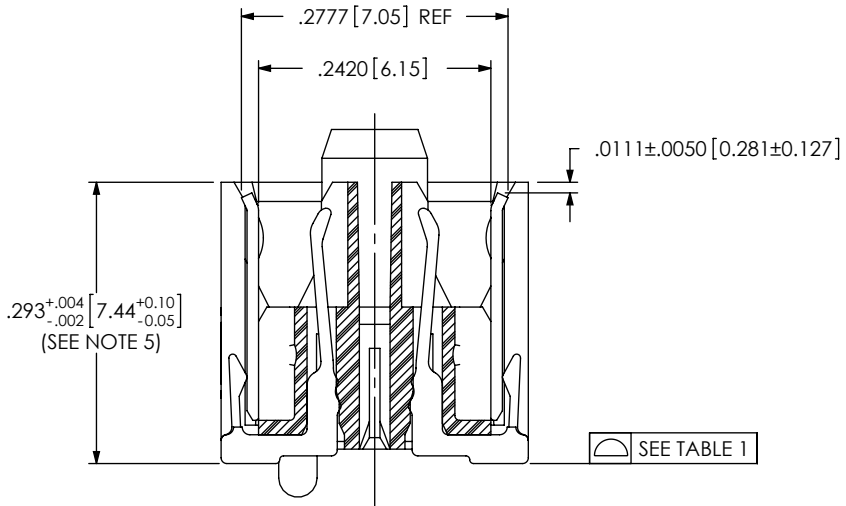
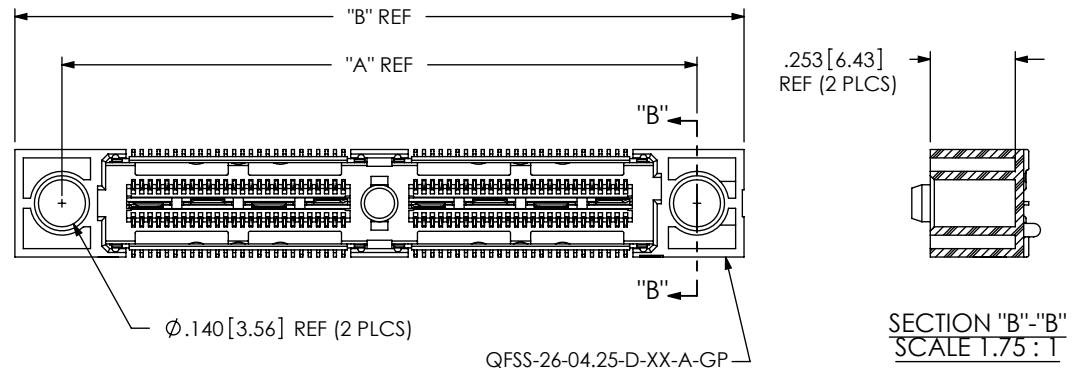

FIG 2

-GP: GUIDE HOLE OPTION
(QFSS-052-04.25-X-D-A-GP SHOWN)
[NOT AVAILABLE WITH -PXX OPTIONS]



PROPRIETARY NOTE

THIS DOCUMENT CONTAINS INFORMATION CONFIDENTIAL AND PROPRIETARY TO SAMTEC, INC. AND SHALL NOT BE REPRODUCED OR TRANSFERRED TO OTHER DOCUMENTS OR DISCLOSED TO OTHERS OR USED FOR ANY PURPOSE OTHER THAN THAT WHICH IT WAS OBTAINED WITHOUT THE EXPRESSED WRITTEN CONSENT OF SAMTEC, INC.

DO NOT SCALE DRAWING

SHEET SCALE: 2.5:1



520 PARK EAST BLVD, NEW ALBANY, IN 47150
PHONE: 812-944-6733 FAX: 812-948-5047
e-Mail: info@SAMTEC.com code: 55322

DESCRIPTION:
.635mm DOUBLE ROW SHIELDED TERMINAL STRIP

DWG. NO.
QFSS-XXX-XX.XX-X-D-X-XXX-XX

BY: CHAD F 05/28/2002 SHEET 2 OF 4

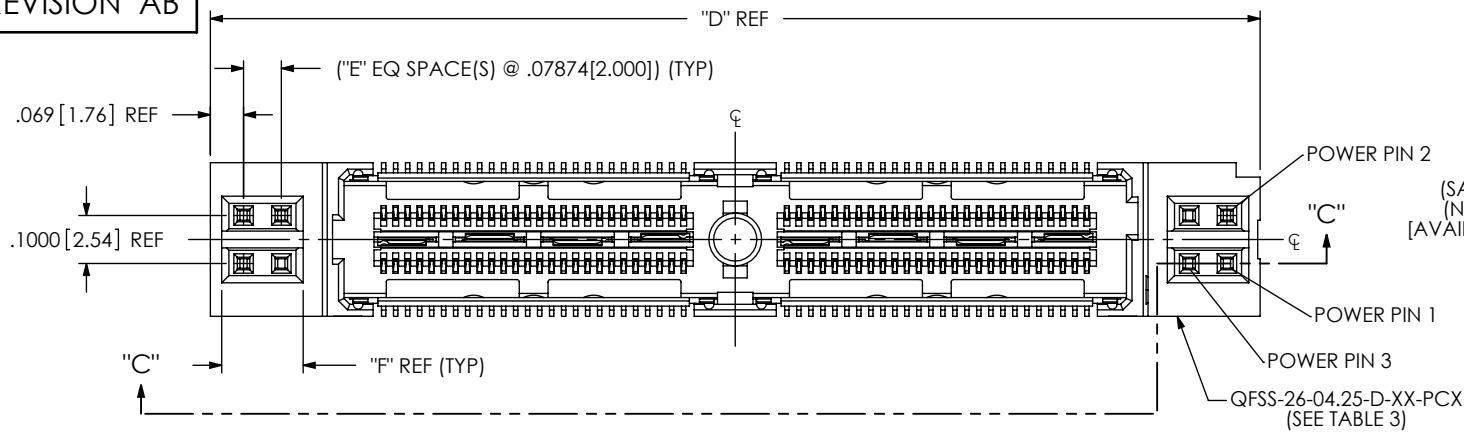
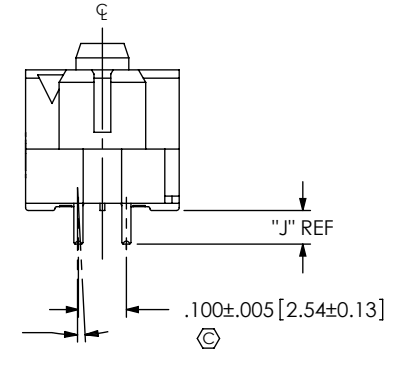
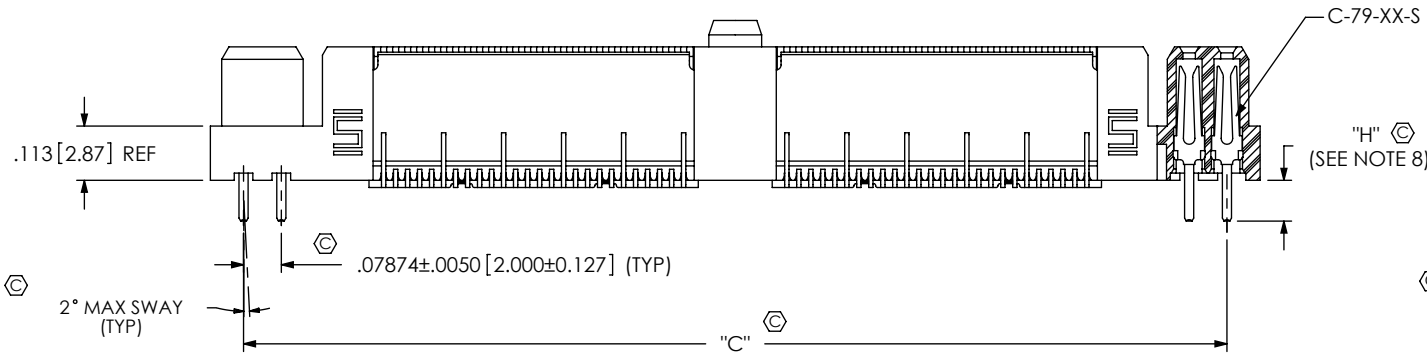
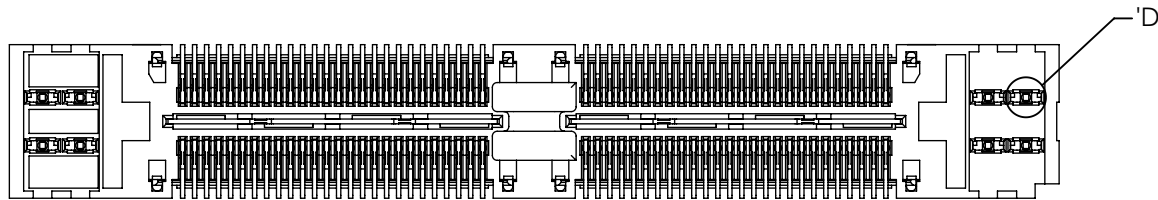

FIG 3
 POWER COMBO OPTIONS
 (QFSS-052-04.25-X-D-PC4 SHOWN)
 (SAME AS FIG 1, UNLESS OTHERWISE STATED)
 (NOT AVAILABLE WITH -A OR -GP OPTIONS)
 [AVAILABLE ON -026, -052 & -078 POSITIONS ONLY]



SECTION "C"-"C"



DETAIL 'D'
 SCALE 8 : 1

POWER OPTION	CONTACT	"H"	"J"
PC4/PC8	C-79-06-S	.085[2.16]	.070[1.78]
PT4/PT8	C-79-09-S	.125[3.18]	.110[2.79]

ASSEMBLY	QFSS-26-04.25-D-XX-PCX	"C"	"D"	"E"	"F"
QFSS-026-01-X-D-X-PX4	QFSS-26-04.25-D-01-PC4	1.209[30.70]	1.347[34.21]	1	.170[4.31]
QFSS-026-01-X-D-X-PX8	QFSS-26-04.25-D-01-PC8	1.524[38.70]	1.662[42.21]	3	.327[8.31]
QFSS-052-01-X-D-X-PX4	QFSS-26-04.25-D-02-PC4	2.049[52.04]	2.187[55.55]	1	.170[4.31]
QFSS-052-01-X-D-X-PX8	QFSS-26-04.25-D-02-PC8	2.364[60.04]	2.502[63.55]	3	.327[8.31]
QFSS-078-01-X-D-X-PX4	QFSS-26-04.25-D-03-PC4	2.889[73.37]	3.027[76.89]	1	.170[4.31]
QFSS-078-01-X-D-X-PX8	QFSS-26-04.25-D-03-PC8	3.204[81.37]	3.342[84.89]	3	.327[8.31]

PROPRIETARY NOTE
 THIS DOCUMENT CONTAINS INFORMATION CONFIDENTIAL AND PROPRIETARY TO SAMTEC, INC. AND SHALL NOT BE REPRODUCED OR TRANSFERRED TO OTHER DOCUMENTS OR DISCLOSED TO OTHERS OR USED FOR ANY PURPOSE OTHER THAN THAT WHICH IT WAS OBTAINED WITHOUT THE EXPRESSED WRITTEN CONSENT OF SAMTEC, INC.

DO NOT SCALE DRAWING
 SHEET SCALE: 2.5:1



520 PARK EAST BLVD, NEW ALBANY, IN 47150
 PHONE: 812-944-6733 FAX: 812-948-5047
 e-Mail: info@SAMTEC.com code: 55322

DESCRIPTION:
 .635mm DOUBLE ROW SHIELDED TERMINAL STRIP
 DWG. NO.
QFSS-XXX-XX.XX-X-D-X-XXX-XX
 BY: CHAD F 05/28/2002 SHEET 3 OF 4

FIG 4
-P: PICK & PLACE PAD OPTION

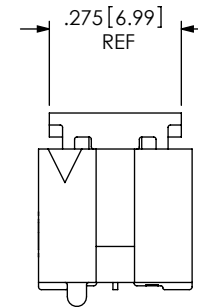
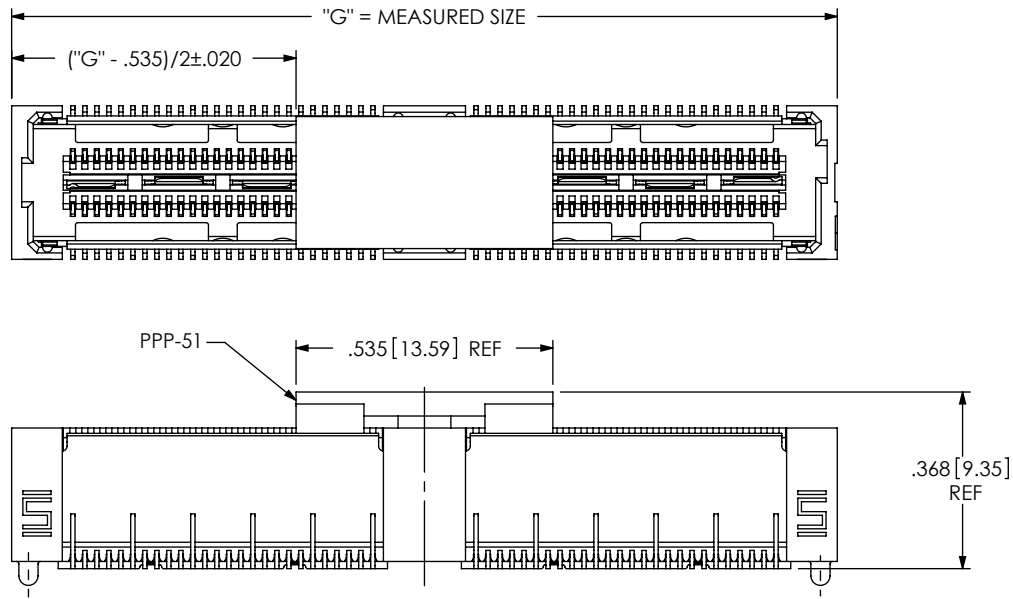
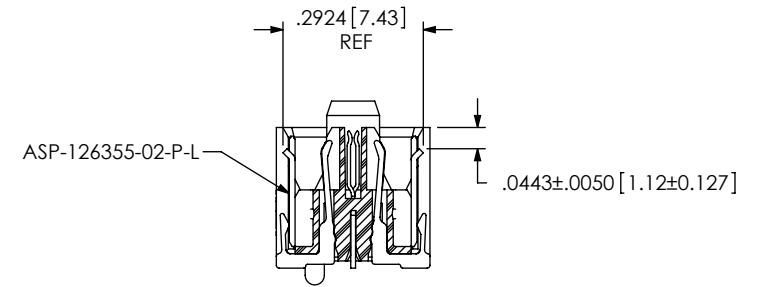
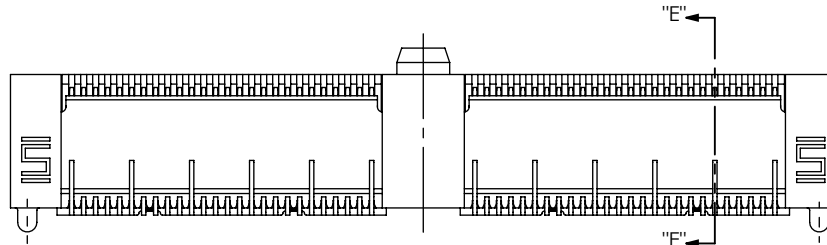

FIG 5
-BM: BLIND MATE SHIELD OPTION
QFSS-052-04.25-X-D-A-BM SHOWN
(SAME AS FIG 1, UNLESS OTHERWISE STATED)



SECTION "E"-"E"

PROPRIETARY NOTE
THIS DOCUMENT CONTAINS INFORMATION
CONFIDENTIAL AND PROPRIETARY TO
SAMTEC, INC. AND SHALL NOT BE REPRODUCED
OR TRANSFERRED TO OTHER DOCUMENTS OR
DISCLOSED TO OTHERS OR USED FOR ANY
PURPOSE OTHER THAN THAT WHICH IT WAS
OBTAINED WITHOUT THE EXPRESSED WRITTEN
CONSENT OF SAMTEC, INC.

DO NOT SCALE DRAWING
SHEET SCALE: 2.5:1



520 PARK EAST BLVD, NEW ALBANY, IN 47150
PHONE: 812-944-6733 FAX: 812-948-5047
e-Mail: info@SAMTEC.com code: 55322

DESCRIPTION:
.635mm DOUBLE ROW SHIELDED TERMINAL STRIP

DWG. NO.
QFSS-XXX-XX.XX-X-D-X-XXX-XX

BY: CHAD F 05/28/2002 SHEET 4 OF 4