

DO NOT SCALE FROM THIS PRINT

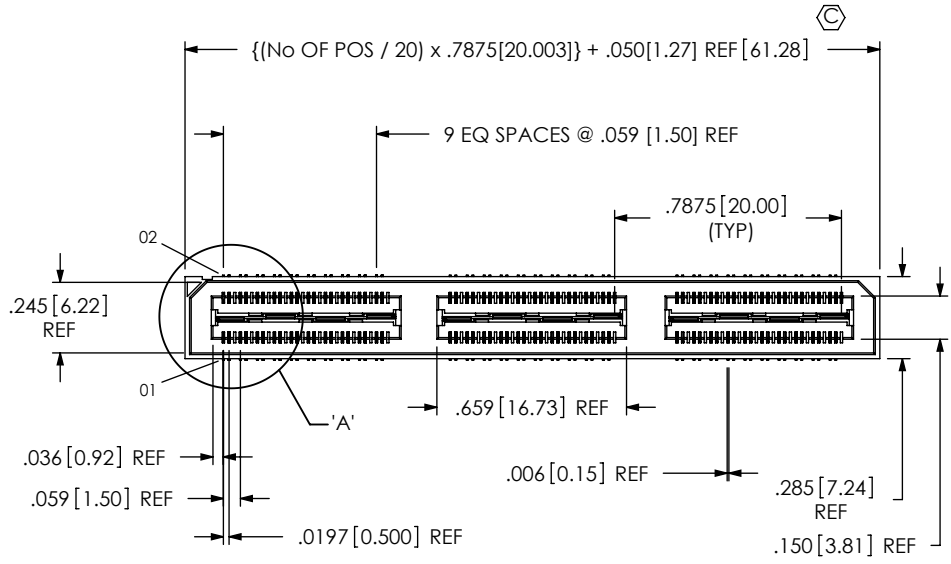

QSH-XXX-XX-X-D-DP-XXX

- No OF POSITIONS  
-020, -040, -060, \*\*080, \*\*100 (PER ROW)  
LEAD STYLE  
-01: .1280 [3.251]
- PLATING SPECIFICATION  
(SEE NOTE 11)  
-F: 3u" FLASH SELECTIVE IN CONTACT AREA, MATTE TIN ON TAIL (USE T-1G2-01-F) (SEE NOTE 9)  
-L: 10u" LIGHT SELECTIVE GOLD IN CONTACT AREA, MATTE TIN ON TAIL (USE T-1G2-01-L) (SEE NOTE 9)  
-H: 30u" HEAVY GOLD IN CONTACT AREA, 3u" GOLD ON TAIL (USE T-1G2-01-G)  
-C: 50u" ELECTRO-POLISHED SELECTIVE GOLD IN CONTACT AREA, MATTE TIN ON TAIL (USE T-1G2-01-L) (SEE NOTE 9)
- OPTION  
-A: ALIGNMENT PINS (USE QSH-30-01-D-XX-A, SEE FIG 2)  
-GP: GUIDE POSTS (USE QSH-30-01-D-XX-GP, SEE FIG 4)  
-LC: LOCKING CLIPS (SEE NOTE 12) (USE LC-08-TM-01, SEE FIG 1)  
-K: POLYIMIDE FILM PAD (USE K-DOT-.325-450-.005, SEE FIG. 3)  
-TR: TAPE & REEL (60 POS MAX)  
-TY: TRAY PACKAGING (NOT AVAILABLE WITH -TR)  
-FL: FRICTION LOCKS (SEE FIG 5, SHEET 3) (NOT AVAILABLE WITH -GP)  
-RTI: RETENTION (MUST USE -A OPTION) (USE QSH-30-01-D-XX-A-RTI & SUB-SC-05-01-FF) (SEE FIG 6, SHEET 3) (NOT AVAILABLE WITH -LC, -GP, OR -FL) (NOT AVAILABLE WITH -080 & -100 POS)  
-L: LATCHING (SEE FIG 7, SHEET 4) (USE QSH-30-01-D-XX-A-L) (NOT AVAILABLE WITH -LC, -GP, -FL, OR -RTI)
- DIFFERENTIAL PAIRS  
-ROW SPECIFICATION  
-D: DOUBLE (USE QSH-30-01-D-XX)  
No OF BANKS
- C-126-01-X CAN BE SUBBED FOR C-126-21-X**  
**\*\* = SEE NOTE 10**

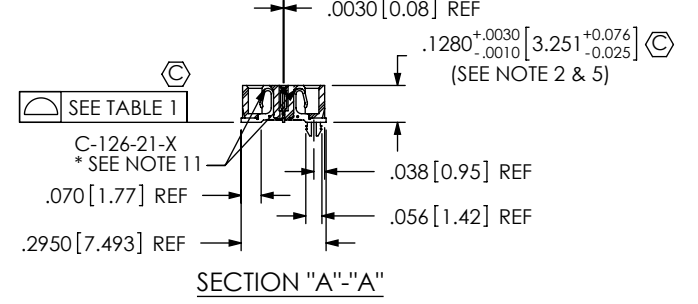
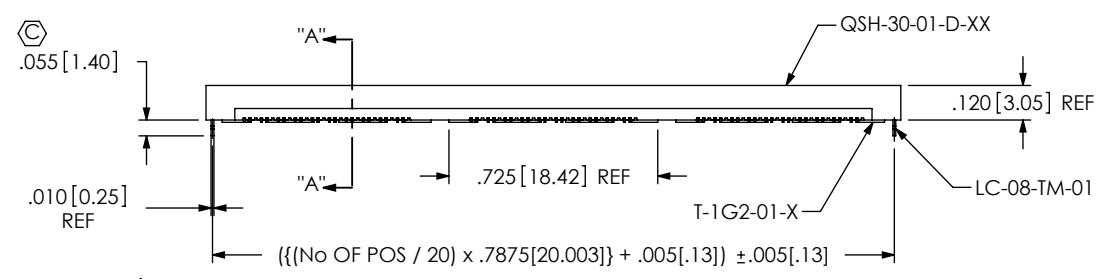

FIG 1  
-LC: LOCKING CLIP OPTION SHOWN

**TABLE 1**

No OF POS	COPLANARITY (INCLUDES GROUND PLANE)
-020 THRU -060	.0040[.102]
-080 THRU -100	.0060[.152]

- NOTES:
- ⊙ REPRESENTS A CRITICAL DIMENSION.
  - MAX VARIANCE: .002 [0.05]
  - MAX BURR ALLOWANCE: .0015 [0.038]
  - MINIMUM PUSHOUT FORCE: 4 OZ
  - DIM APPLIES TO GROUND PLANE AND CONTACT.
  - MINIMUM GROUND PLANE RETENTION: 8 OZ
  - L PLATING CAN BE SUBSTITUTED FOR -F PLATING.
  - SUB-SC-05-01-XX RETENTION TO BE 1.0 LBF IN BODY.
  - MAY SUB C-126-01-X for C-126-21-X.
  - FOR NEW APPLICATIONS REQUIRING THESE POSITIONS PLEASE CONTACT SAMTEC INTERCONNECT PROCESSING GROUP.
  - FOR -80, -100 POSITIONS USE C-269-11-X. DO NOT SUB C-126.
  - DUE TO THE HIGH AMOUNT OF INSERTION FORCE NEEDED, THE -LC OPTION IS NOT COMPATIBLE WITH AUTO PLACEMENT. SAMTEC RECOMMENDS MANUAL PLACEMENT FOR ALL ASSEMBLIES WITH THE -LC OPTION."

<p>UNLESS OTHERWISE SPECIFIED, DIMENSIONS ARE IN INCHES. TOLERANCES ARE: DECIMALS ANGLES .XX: ±.01 [.3] 2° .XXX: ±.005 [.13] .XXXX: ±.0020 [.051]</p>	<p>PROPRIETARY NOTE THIS DOCUMENT CONTAINS INFORMATION CONFIDENTIAL AND PROPRIETARY TO SAMTEC, INC. AND SHALL NOT BE REPRODUCED OR TRANSFERRED TO OTHER DOCUMENTS OR DISCLOSED TO OTHERS OR USED FOR ANY PURPOSE OTHER THAN THAT WHICH IT WAS OBTAINED WITHOUT THE EXPRESSED WRITTEN CONSENT OF SAMTEC, INC.</p>		
		<p>520 PARK EAST BLVD, NEW ALBANY, IN 47150 PHONE: 812-944-6733 FAX: 812-948-5047 e-Mail info@SAMTEC.com code 55322</p>	
<p>MATERIAL: DO NOT SCALE DRAWING SHEET SCALE: 3:2 INSULATOR: BLACK, LCP FLAMMABILITY RATING: UL94V0 TERMINAL: PHOS BRONZE GROUND PLANE: PHOS BRONZE</p>	<p>DESCRIPTION: .5mm DIFFERENTIAL PAIRS HS SOCKET ASSEMBLY</p>		
	<p>DWG. NO. QSH-XXX-XX-X-D-DP-XXX</p>		
	<p>BY: KEVIN B 06/13/00 SHEET 1 OF 4</p>		

F:\DWG\MISC\MKTG\QSH-XXX-XX-X-D-DP-XXX-MKT.SLDDRW

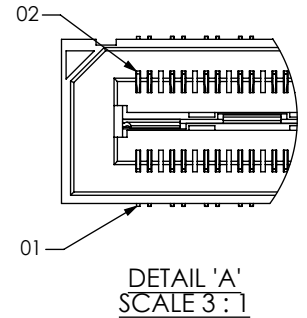
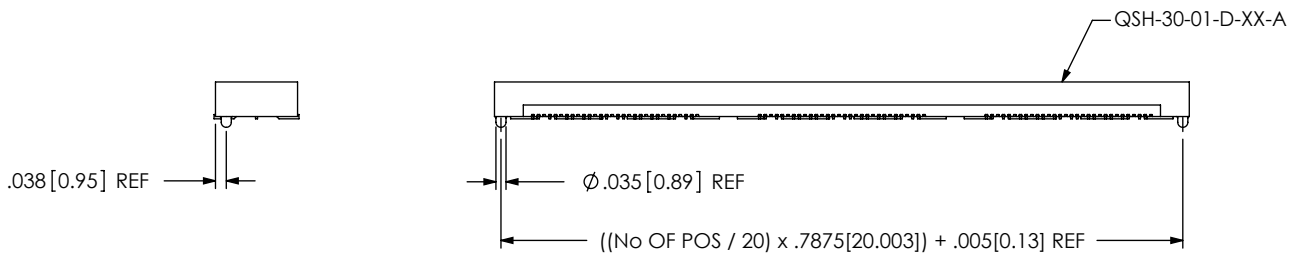

FIG 2  
-A: ALIGNMENT PIN OPTION SHOWN

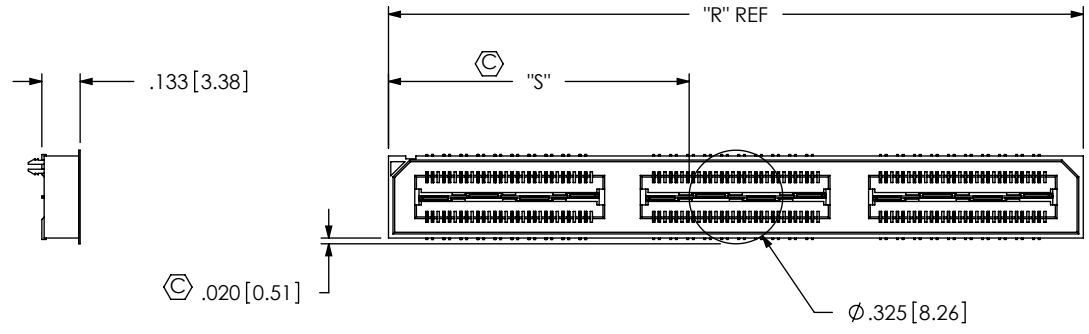

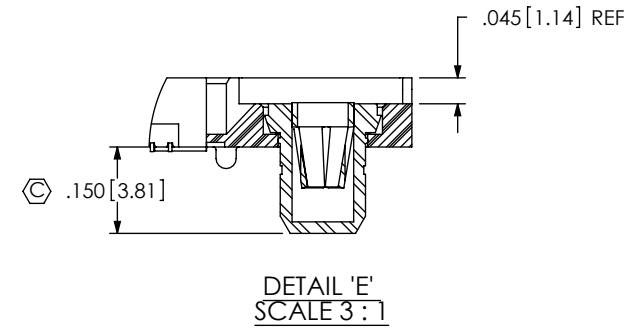
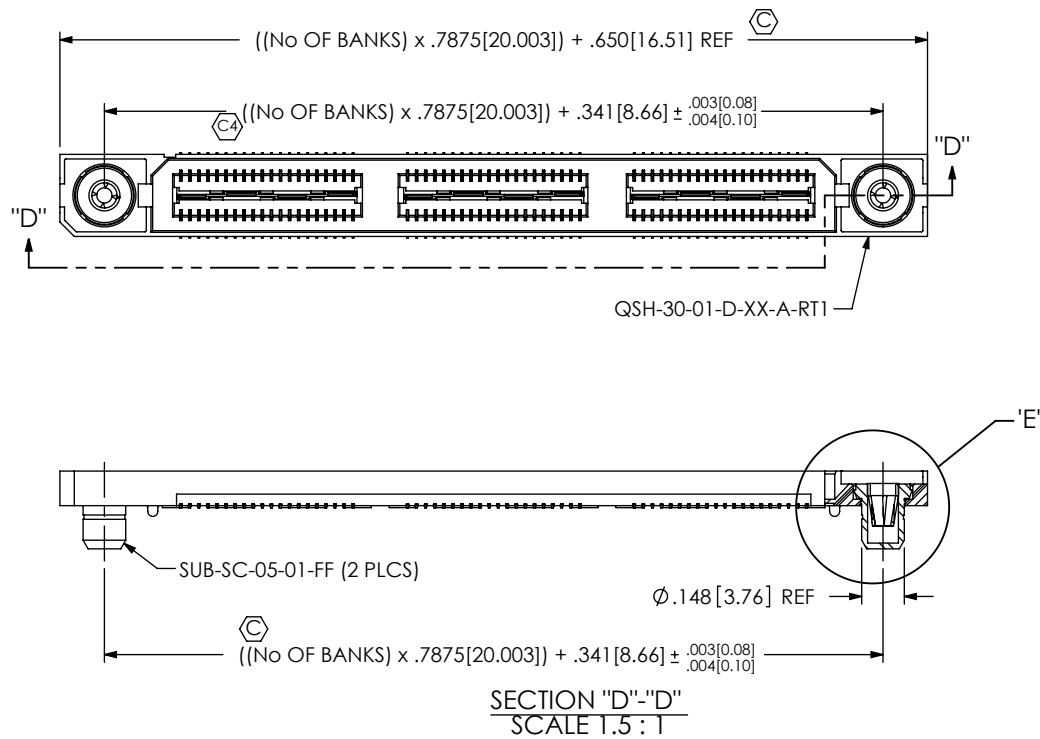
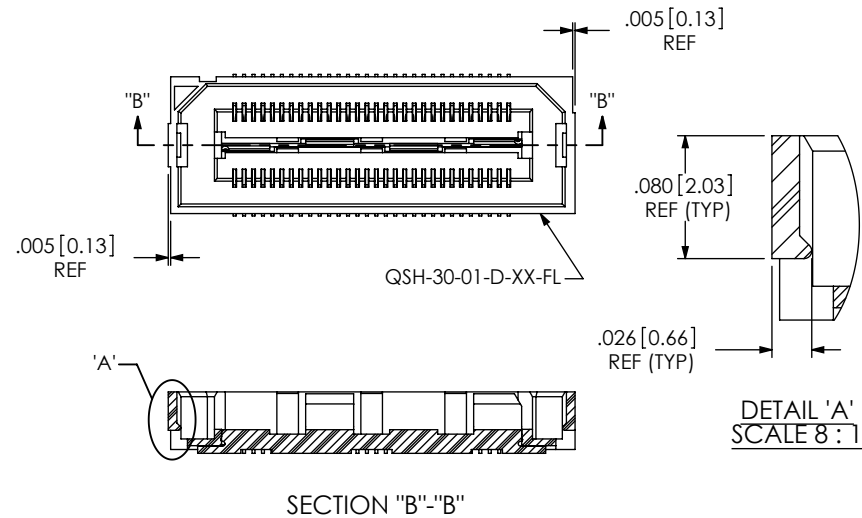
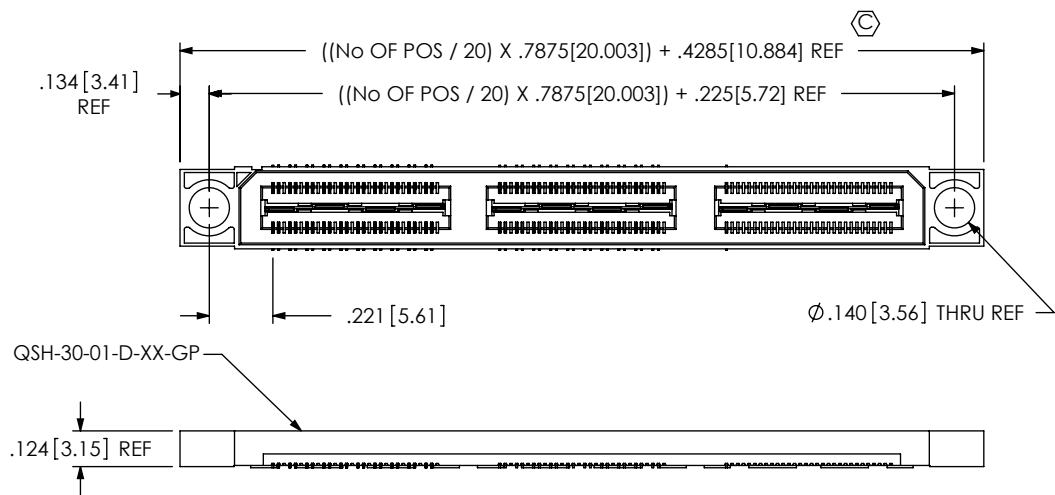

FIG 3  
-K: POLYIMIDE FILM PAD

NOTE: "R" = ((No OF POSITIONS / 20) x .7875[20.003]) + .050[1.27]  
 "S" = (("R" - .325[8.26]) / 2) ±.020[.51]

<p><b>PROPRIETARY NOTE</b>                  THIS DOCUMENT CONTAINS INFORMATION CONFIDENTIAL AND PROPRIETARY TO SAMTEC, INC. AND SHALL NOT BE REPRODUCED OR TRANSFERRED TO OTHER DOCUMENTS OR DISCLOSED TO OTHERS OR USED FOR ANY PURPOSE OTHER THAN THAT WHICH IT WAS OBTAINED WITHOUT THE EXPRESSED WRITTEN CONSENT OF SAMTEC, INC.</p> <p>DO NOT SCALE DRAWING</p> <p>SHEET SCALE: 1.5:1</p>		
	<p>520 PARK EAST BLVD, NEW ALBANY, IN 47150                  PHONE: 812-944-6733 FAX: 812-948-5047                  e-Mail info@SAMTEC.com code 55322</p>	
	<p>DESCRIPTION:                  .5mm DIFFERENTIAL PAIRS HS SOCKET ASSEMBLY</p>	
	<p>DWG. NO.  <b>QSH-XXX-XX-X-D-DP-XXX</b></p>	
<p>BY: KEVIN B</p>	<p>06/13/00</p>	<p>SHEET 2 OF 4</p>



<p><b>PROPRIETARY NOTE</b>                  THIS DOCUMENT CONTAINS INFORMATION CONFIDENTIAL AND PROPRIETARY TO SAMTEC, INC. AND SHALL NOT BE REPRODUCED OR TRANSFERRED TO OTHER DOCUMENTS OR DISCLOSED TO OTHERS OR USED FOR ANY PURPOSE OTHER THAN THAT WHICH IT WAS OBTAINED WITHOUT THE EXPRESSED WRITTEN CONSENT OF SAMTEC, INC.</p> <p>DO NOT SCALE DRAWING</p> <p>SHEET SCALE: 1.25:1</p>		
	<p>520 PARK EAST BLVD. NEW ALBANY, IN 47150                  PHONE: 812-944-6733 FAX: 812-948-5047                  e-Mail: info@SAMTEC.com code 55322</p>	
	<p>DESCRIPTION:                  .5mm DIFFERENTIAL PAIRS HS SOCKET ASSEMBLY</p>	
	<p>DWG. NO.  <b>QSH-XXX-XX-X-D-DP-XXX</b></p>	
<p>BY: KEVIN B 06/13/00</p>		<p>SHEET 3 OF 4</p>

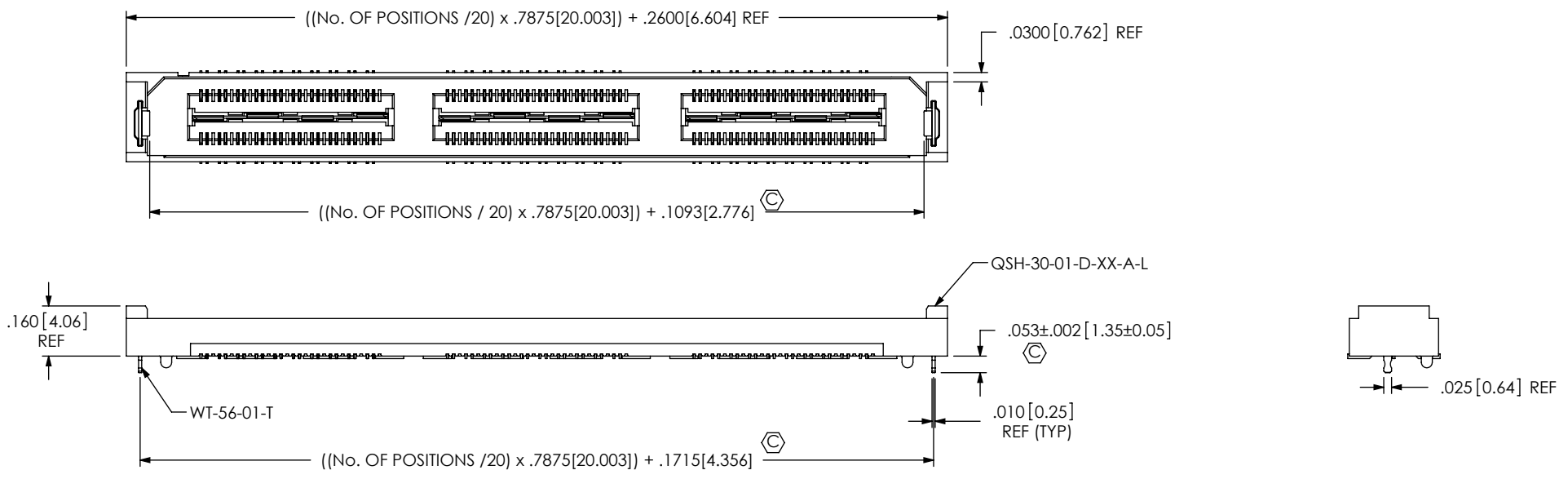



FIG 7  
 -L: RETENTION OPTION  
 (NOT AVAILABLE WITH -LC, -GP, -FL, OR -RT1 OPTIONS)  
 (SAME AS FIG 1, UNLESS OTHERWISE STATED)

<p>PROPRIETARY NOTE</p> <p>THIS DOCUMENT CONTAINS INFORMATION CONFIDENTIAL AND PROPRIETARY TO SAMTEC, INC. AND SHALL NOT BE REPRODUCED OR TRANSFERRED TO OTHER DOCUMENTS OR DISCLOSED TO OTHERS OR USED FOR ANY PURPOSE OTHER THAN THAT WHICH IT WAS OBTAINED WITHOUT THE EXPRESSED WRITTEN CONSENT OF SAMTEC, INC.</p> <p>DO NOT SCALE DRAWING</p> <p>SHEET SCALE: 2:1</p>		
	<p>520 PARK EAST BLVD, NEW ALBANY, IN 47150                  PHONE: 812-944-6733 FAX: 812-948-5047                  e-Mail info@SAMTEC.com code 55322</p>	
	<p>DESCRIPTION:                  .5mm DIFFERENTIAL PAIRS HS SOCKET ASSEMBLY</p>	
	<p>DWG. NO.                  QSH-XXX-XX-X-D-DP-XXX</p>	
<p>BY: KEVIN B</p>	<p>06/13/00</p>	<p>SHEET 4 OF 4</p>