

◇ = ASO ONLY (APPLICATION SPECIFIC ORDER)

STYLE	"B"	"C"	BODY	GROUND PLANE	TERMINAL	MATED HEIGHT WITH QSE-DP-01
-01	.1680 [4.267]	.1600 [4.064]	QTE-20-01-D-XX	T-1G1-01-XXX	T-1S39-01-XXX	.197 [5.00] REF
-02	.2861 [7.267]	.2781 [7.064]	QTE-20-02-D-XX	T-1G1-02-XXX	T-1S59-02-XXX	.315 [8.00] REF
-03	.4042 [10.267]	.3962 [10.063]	QTE-20-03-D-XX	T-1G1-03-XXX	T-1S39-03-XXX	.433 [11.00] REF

No OF POS	"A"	"D"
-014	.788 [20.00]	.728 [18.48]
-028	1.575 [40.01]	1.515 [38.48]
-042	2.363 [60.01]	2.303 [58.48]
*-056	3.150 [80.01]	3.090 [78.49]
*-070	3.938 [100.01]	3.878 [98.49]

* = SEE NOTES 12 & 15

No OF POSITIONS	COPLANARITY (INCLUDES GROUND PLANE)
-014 THRU -042	.004 [0.10]
*-056 THRU *-070	.006 [0.15]

* = SEE NOTES 12 & 15

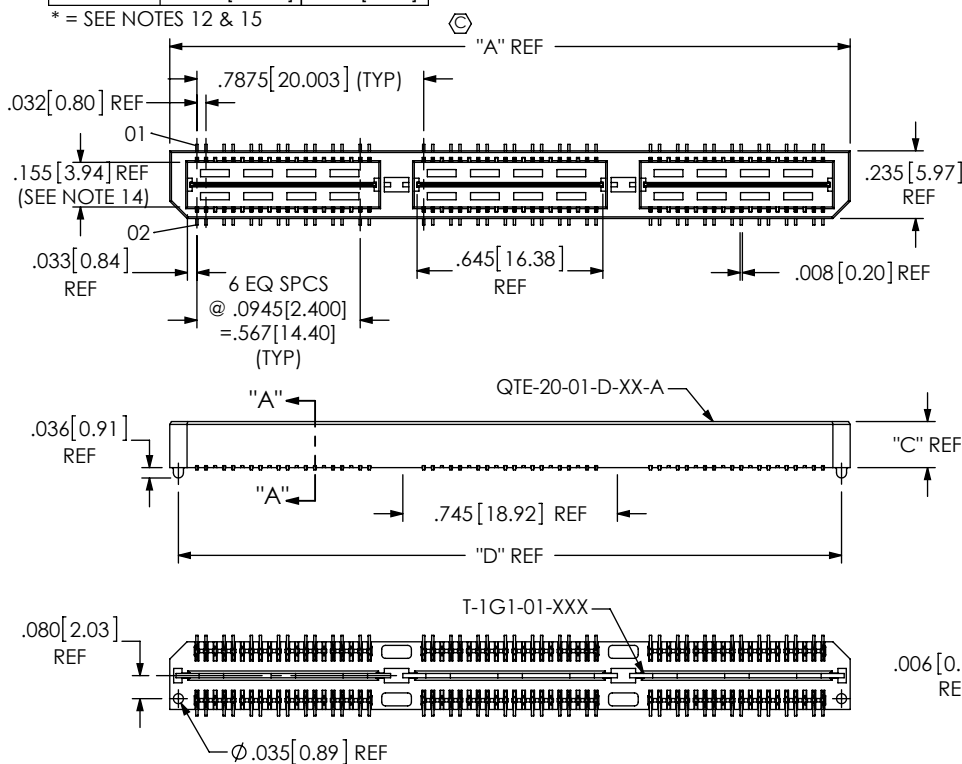

FIG 1

-A: ALIGNMENT PIN OPTION (QTE-042-01-XXX-D-DP-A SHOWN) (STYLE -01, -02 & -03 ONLY)

DETAIL 'B' SCALE 6:1

QTE-XXX-XX-XXX-D-DP-XXX

- No OF POSITIONS**
 -014, -028, -042, *-056, *-070 (PER ROW)
 (*SEE NOTES 12 & 15)
- LEAD STYLE**
 -01: .1680 [4.267] (SEE FIG. 1)
 -02: .2861 [7.264] (SEE FIG. 1)
 -03: .4042 [1.123] (SEE FIG. 1)
 ◇ -04: .600 [15.24] (SEE FIG. 4, SHT. 3)
 ◇ -05: .718 [18.237] (SEE FIG. 4, SHT. 3)
 ◇ -06: .835 [21.209] (SEE FIG. 4, SHT. 3)
 ◇ -07: .954 [24.232] (SEE FIG. 4, SHT. 3)
 ◇ -08: 1.151 [29.24] (SEE FIG. 4, SHT. 3)
 ◇ -09: .522 [13.258] (SEE FIG. 4, SHT. 3)
 ◇ -10: .5606 [14.239] (SEE FIG. 4, SHT. 3)
- PLATING SPECIFICATION**
 -F: 3µ" FLASH GOLD IN CONTACT AREA, MATTE TIN ON TAIL (USE T-1SXX-XX-F, T-1G1-XX-F) (SEE NOTE 9)
 -L: 10µ" LIGHT GOLD IN CONTACT AREA, MATTE TIN ON TAIL (USE T-1SXX-XX-L, T-1G1-XX-L)
 -H: 30µ" HEAVY GOLD IN CONTACT AREA, 3µ" GOLD ON TAIL (USE T-1SXX-XX-H, T-1G1-XX-G)
 -C: 50µ" ELECTRO-POLISHED SELECTIVE IN CONTACT AREA, MATTE TIN ON TAIL (USE T-1SXX-XX-C, T-1G1-XX-L)
 -STL: 30µ" HEAVY SELECTIVE GOLD IN CONTACT AREA, TIN LEAD ON TAIL (USE T-1SXX-XX-STL, T-1G1-XX-STL)
 -FTL: 3µ" FLASH SELECTIVE GOLD IN CONTACT AREA, TIN LEAD ON TAIL (USE T-1SXX-XX-FTL, T-1G1-XX-FTL)
- OPTION**
 -A: ALIGNMENT PINS
 -LC: LOCKING CLIPS (SEE NOTE 13) (USE LC-08-TM-01) (SEE FIG 2, SHT 2)
 -K: POLYIMIDE FILM (USE K-DOT-276-.375-.005) (SEE FIG 3, SHT 2) (N/A ON STYLES -07 & -08)
 -GP: GUIDE POSTS (AVAILABLE ON -01 ONLY) (USE QTE-20-01-D-XX-X-GP) (SEE FIG 4, SHT 3)
 -TR: TAPE & REEL (42 POS. MAX) (NOT AVAILABLE ON -05, -06, -07, -08 LEAD STYLES) (028 POS MAX FOR -GP OPTION)
 -RT1: RETENTION OPTION (SEE FIG 9, SHT 5) (ONLY AVAILABLE ON -01 LEAD STYLE) (MUST USE -A OPTION) (USE QTE-20-01-D-XX-A-RT1 & T-1R36-01-F) (NOT AVAILABLE WITH -LC, -GP, OR -L) (NOT AVAILABLE ON -056 & -070 POS)
 -L: LATCHING OPTION (28 POS. MAX.) (SEE FIG 10, SHT 5) (MUST USE -A OPTION) (AVAILABLE ON -01 ONLY) (NOT AVAILABLE WITH -LC, -GP, OR -RT1)
- BODY STYLE**
 -DP: DIFFERENTIAL PAIRS
- ROW SPECIFICATION**
 -D: DOUBLE (USE QTE-20-XX-D-XX & QTEH-20-XX-D-XX)
 No OF BANKS

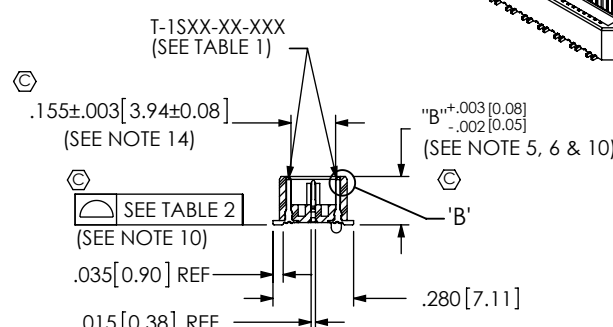
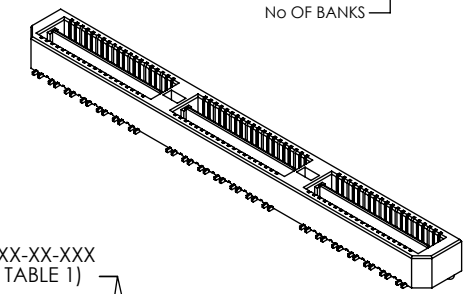

SECTION "A"-"A"

NOTES:

1. Ⓢ REPRESENTS A CRITICAL DIMENSION.
2. MINIMUM TERMINAL RETENTION: 5 OZ.
3. MINIMUM GROUND PLANE RETENTION: 1 LB
4. PARTS TO BE MOLDED TO POSITION.
5. MAXIMUM VARIANCE OF .002 [0.05]
6. DIMENSION APPLIES TO TERMINALS AND GROUND PLANE.
7. DELETED.
8. DELETED.
9. -L PLATING CAN BE SUBSTITUTED FOR -F PLATING.
10. GROUND PLANE PRESS HEIGHT MUST BE .003 [0.08] LESS THAN THE MAX HEIGHT OR .001 [0.03] GREATER THAN THE MINIMUM HEIGHT OF THE TERMINALS.
11. T-1R36 RETENTION TO BODY TO BE 1.0 LBF.
12. FOR NEW APPLICATIONS REQUIRING THESE POSITIONS, PLEASE CONTACT SAMTEC INTERCONNECT PROCESSING GROUP.
13. DUE TO THE HIGH AMOUNT OF INSERTION FORCE NEEDED, THE -LC OPTION IS NOT COMPATIBLE WITH AUTO PLACEMENT. SAMTEC RECOMMENDS MANUAL PLACEMENT FOR ALL ASSEMBLIES WITH THE -LC OPTION.
14. MAXIMUM PIN CAN EXTEND PAST WALL: .003 [0.08]
15. AVAILABLE FOR EXISTING CUSTOMERS ONLY.

UNLESS OTHERWISE SPECIFIED, DIMENSIONS ARE IN INCHES. TOLERANCES ARE: DECIMALS: .XX: ±.01 [3] .XXX: ±.005 [13] .XXXX: ±.0020 [051]	PROPRIETARY NOTE THIS DOCUMENT CONTAINS INFORMATION CONFIDENTIAL AND PROPRIETARY TO SAMTEC, INC. AND SHALL NOT BE REPRODUCED OR TRANSFERRED TO OTHER DOCUMENTS OR DISCLOSED TO OTHERS OR USED FOR ANY PURPOSE OTHER THAN THAT WHICH IT WAS OBTAINED WITHOUT THE EXPRESSED WRITTEN CONSENT OF SAMTEC, INC.		
		520 PARK EAST BLVD. NEW ALBANY, IN 47150 PHONE: 812-944-6733 FAX: 812-948-5047 e-Mail: info@SAMTEC.com code 53322	
MATERIAL: DO NOT SCALE DRAWING SHEET SCALE: 1.5:1	INSULATOR: LCP, UL94V-0; COLOR: BLACK TERMINAL: PHOS BRONZE GROUND PLANE: PHOS BRONZE	DESCRIPTION: .8mm DIFFERENTIAL PAIRS HS TERMINAL ASSEMBLY	DWG. NO. QTE-XXX-XX-XXX-D-DP-XXX
BY: DEAN P 4/28/2000		SHEET 1 OF 5	

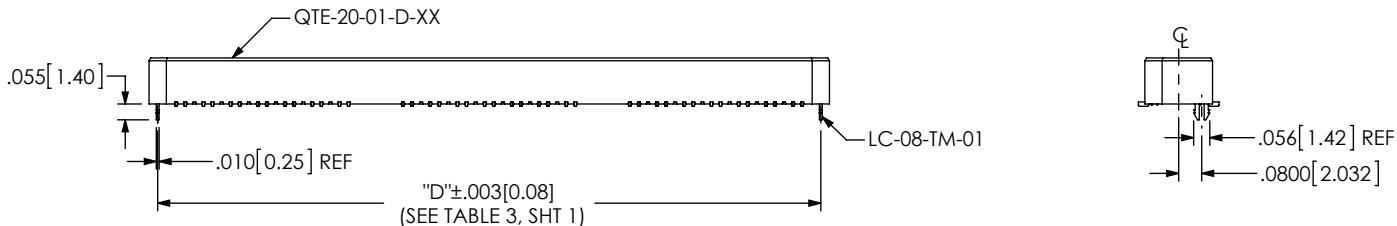

FIG 2
 -LC: LOCKING CLIP OPTION
 (QTS-042-01-XXX-D-DP-LC SHOWN)
 (DIFFERENT AS SHOWN, OTHERWISE SAME AS FIG 1)

No OF POS	"R"				"S"			
	-LC, -A, -FL	-GP, -SD	-RT1	-L	-LC, -A, -FL	-GP, -SD	-RT1	-L
-014	.788 [20.00]	1.305 [33.15]	1.438 [36.53]	.906 [23.00]	.256 [6.50]	.515 [13.07]	.581 [14.76]	.315 [7.99]
-028	1.575 [40.01]	2.093 [53.15]	2.226 [56.53]	1.693 [43.00]	.650 [16.50]	.908 [23.07]	.975 [24.76]	.709 [18.00]
-042	2.363 [60.01]	2.880 [73.15]	3.013 [76.53]	N/A	1.043 [26.50]	1.302 [33.07]	1.369 [34.76]	N/A
*-056	3.150 [80.01]	3.668 [93.15]	N/A	N/A	1.437 [36.50]	1.696 [43.07]	N/A	N/A
*-070	3.938 [100.01]	4.455 [113.16]	N/A	N/A	1.831 [46.50]	2.090 [53.07]	N/A	N/A

STYLE	"T"
-01	.173[4.39]
-02	.291[7.39]
-03	.409[10.39]
-04	.605[15.37]
-05	.723[18.36]
-06	.841[21.36]
-09	.527[13.39]
-10	.567[14.37]

* = SEE NOTES 12 & 15

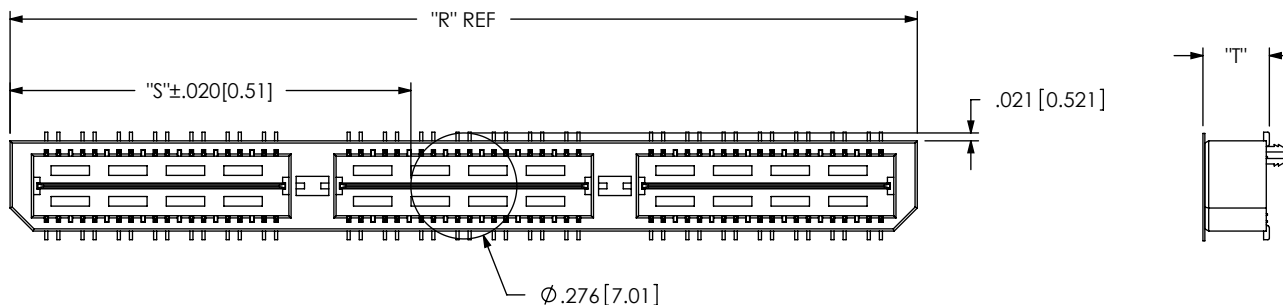



FIG 3
 -K: POLYIMIDE FILM PAD
 (USE K-DOT-.276-.375-.005)

<p>PROPRIETARY NOTE</p> <p>THIS DOCUMENT CONTAINS INFORMATION CONFIDENTIAL AND PROPRIETARY TO SAMTEC, INC. AND SHALL NOT BE REPRODUCED OR TRANSFERRED TO OTHER DOCUMENTS OR DISCLOSED TO OTHERS OR USED FOR ANY PURPOSE OTHER THAN THAT WHICH IT WAS OBTAINED WITHOUT THE EXPRESSED WRITTEN CONSENT OF SAMTEC, INC.</p> <p>DO NOT SCALE DRAWING</p> <p>SHEET SCALE: 2:1</p>		
	<p>520 PARK EAST BLVD, NEW ALBANY, IN 47150 PHONE: 812-944-6733 FAX: 812-948-5047 e-Mail: info@SAMTEC.com code 55322</p>	
	<p>DESCRIPTION: .8mm DIFFERENTIAL PAIRS HS TERMINAL ASSEMBLY</p>	
	<p>DWG. NO. QTE-XXX-XX-XXX-D-DP-XXX</p>	
<p>BY: DEAN P 4/28/2000</p>		<p>SHEET 2 OF 5</p>

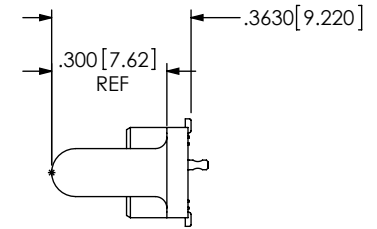
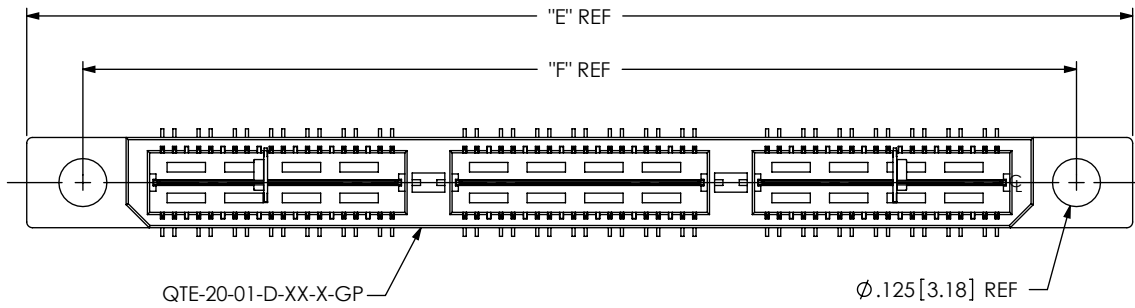

FIG 4
 -GP: GUIDE POST OPTION
 (QTE-042-01-XXX-D-DP-GP SHOWN)
 (DIFFERENT AS SHOWN, OTHERWISE SAME AS FIG 1)
 (AVAILABLE ON STYLE -01 ONLY)

POS	"E"	"F"
-014	1.305 [33.15]	1.013 [25.72]
-028	2.093 [53.15]	1.800 [45.72]
-042	2.880 [73.15]	2.588 [65.72]
*-056	3.668 [93.15]	3.375 [85.73]
*-070	4.455 [113.16]	4.163 [105.73]

* = SEE NOTES 12 & 15

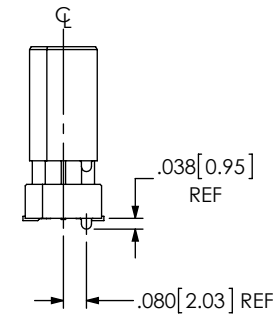
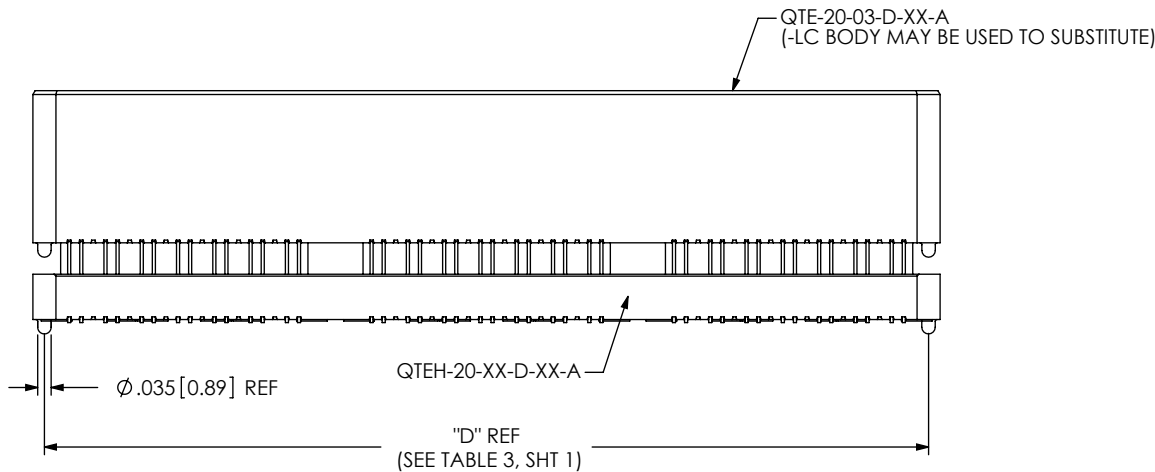

FIG 5
 (QTE-020-04-XXX-D-A SHOWN)
 (DIFFERENT AS SHOWN, OTHERWISE SAME AS FIG 1)
 (STYLES -04, -05, -06, -07, -08, -09 & -10, SEE TABLE 7, SHT 4)

<p>PROPRIETARY NOTE THIS DOCUMENT CONTAINS INFORMATION CONFIDENTIAL AND PROPRIETARY TO SAMTEC, INC. AND SHALL NOT BE REPRODUCED OR TRANSFERRED TO OTHER DOCUMENTS OR DISCLOSED TO OTHERS OR USED FOR ANY PURPOSE OTHER THAN THAT WHICH IT WAS OBTAINED WITHOUT THE EXPRESSED WRITTEN CONSENT OF SAMTEC, INC.</p> <p>DO NOT SCALE DRAWING</p> <p>SHEET SCALE: 2:1</p>	
	<p>520 PARK EAST BLVD, NEW ALBANY, IN 47150 PHONE: 812-944-6733 FAX: 812-948-5047 e-Mail info@SAMTEC.com code 55322</p>
	<p>DESCRIPTION: .8mm DIFFERENTIAL PAIRS HS TERMINAL ASSEMBLY</p>
	<p>DWG. NO. QTE-XXX-XX-XXX-D-DP-XXX</p>
<p>BY: DEAN P 4/28/2000</p>	<p>SHEET 3 OF 5</p>

TABLE 7						MATED HEIGHT WITH QSE-DP-01
STYLE	"B"	GROUND PLANE	TERMINAL	FILLER BODY	SPACER BODY	
-04	.600[15.24]	T-1G1-04-XXX	T-1S41-04-XXX	QTE-20-03-D-XX	QTEH-20-01-D-XX-X	.630 [16.00] REF
-05	.718[18.237]	T-1G1-05-XXX	T-1S41-05-XXX	QTE-20-03-D-XX	QTEH-20-01-D-XX-X	.748 [19.00] REF
-06	.835[21.209]	T-1G1-06-XXX	T-1S41-06-XXX	QTE-20-03-D-XX	QTEH-20-02-D-XX-X	.866 [22.00] REF
-07	.954[24.232]	T-1G17-01-XXX	T-1S61-21-XXX	QTEH-20-04-D-XX-X	QTE-20-02-D-XX-X	.984 [25.00] REF
-08	1.151[29.24]	T-1G17-02-XXX	T-1S61-22-XXX	QTEH-20-04-D-XX-X	QTE-20-02-D-XX-X	1.181 [30.00] REF
-09	.522[13.259]	T-1G1-09-XXX	T-1S60-09-XXX	QTEH-20-01-D-XX-X	QTE-20-02-D-XX-X	.551[14.00] REF
-10	.5606[14.239]	T-1G1-10-XXX	T-1S60-10-XXX	QTEH-20-01-D-XX-X	QTE-20-02-D-XX-X	.591[15.00] REF

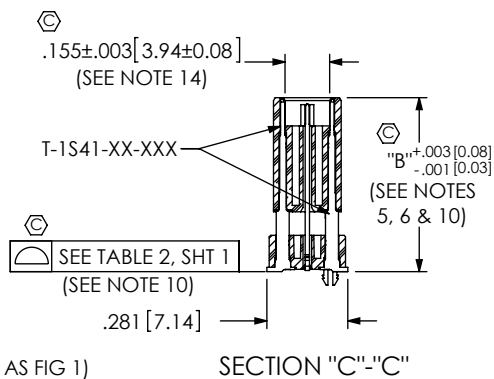
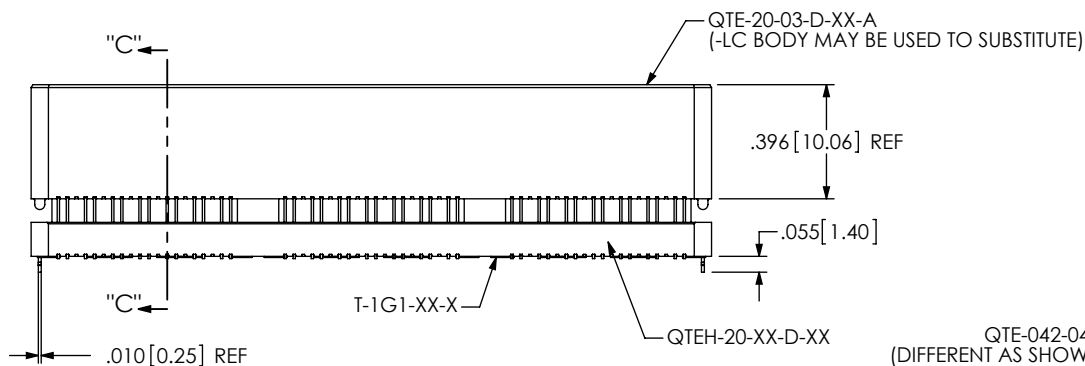
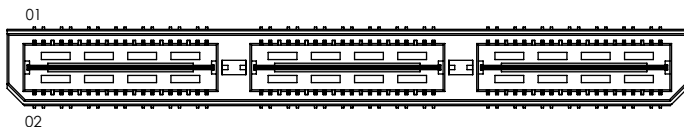

FIG 6
QTE-042-04-X-D-DP-LC SHOWN
(DIFFERENT AS SHOWN, OTHERWISE SAME AS FIG 1)
(STYLES -04, -05 & -06)

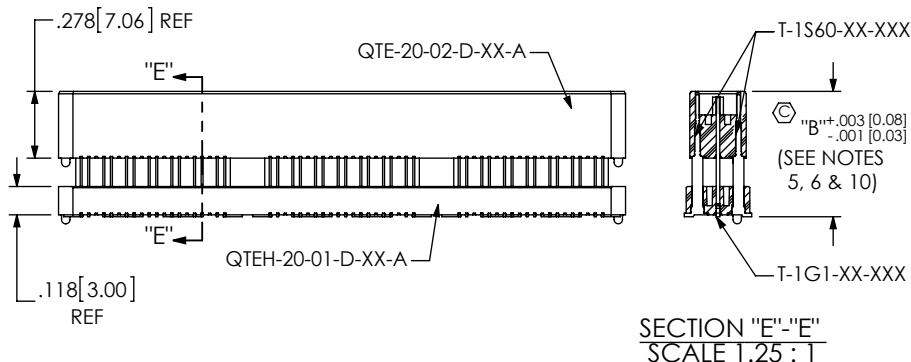
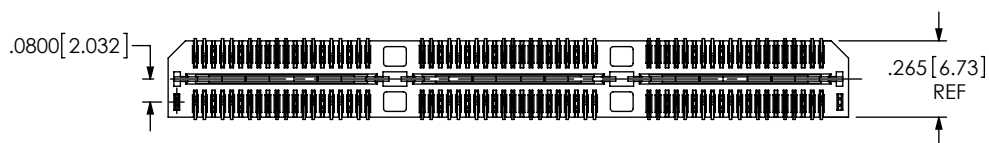

FIG 8
QTE-042-09-X-D-DP-A SHOWN
(DIFFERENT AS SHOWN, OTHERWISE SAME AS FIG 6)
(STYLES -09 & -10)

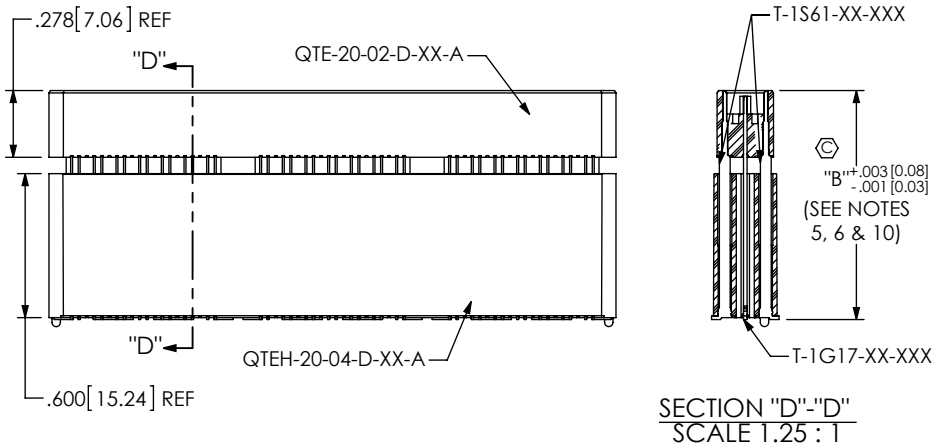

FIG 7
QTE-042-07-X-D-DP-A SHOWN
(DIFFERENT AS SHOWN, OTHERWISE SAME AS FIG 6)
(STYLES -07 & -08)

SECTION "D"-"D"
SCALE 1.25 : 1

C:\EnterpriseVault\DWG\MISC\MKTG\QTE-XXX-XX-XXX-D-DP-XXX-MKT.SLDDRW

PROPRIETARY NOTE
THIS DOCUMENT CONTAINS INFORMATION
CONFIDENTIAL AND PROPRIETARY TO
SAMTEC, INC. AND SHALL NOT BE REPRODUCED
OR TRANSFERRED TO OTHER DOCUMENTS OR
DISCLOSED TO OTHERS OR USED FOR ANY
PURPOSE OTHER THAN THAT WHICH IT WAS
OBTAINED WITHOUT THE EXPRESSED WRITTEN
CONSENT OF SAMTEC, INC.

DO NOT SCALE DRAWING
SHEET SCALE: 1.5:1



520 PARK EAST BLVD, NEW ALBANY, IN 47150
PHONE: 812-944-6733 FAX: 812-948-5047
e-Mail: info@SAMTEC.com code 55322

DESCRIPTION:
.8mm DIFFERENTIAL PAIRS HS TERMINAL ASSEMBLY

DWG. NO.
QTE-XXX-XX-XXX-D-DP-XXX

BY: DEAN P 4/28/2000 SHEET 4 OF 5

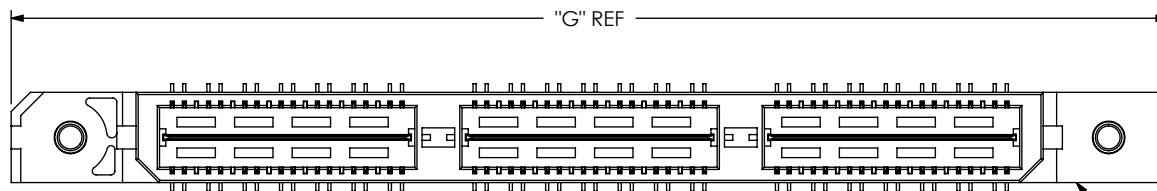

POS	"G"	"H"
-014	1.438 [36.53]	1.129 [28.68]
-028	2.226 [56.53]	1.917 [48.68]
-042	3.013 [76.53]	2.704 [68.68]
*-056	N/A	N/A
*-070	N/A	N/A

* = SEE NOTES 12 & 15

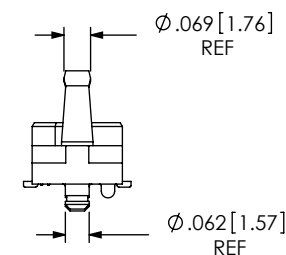
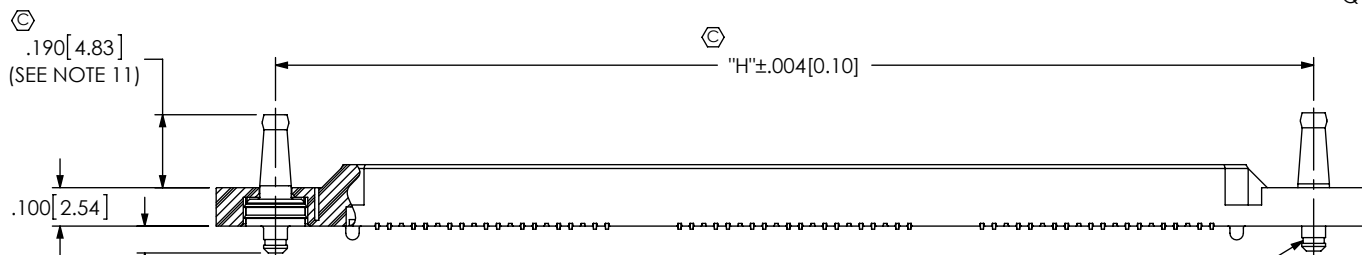
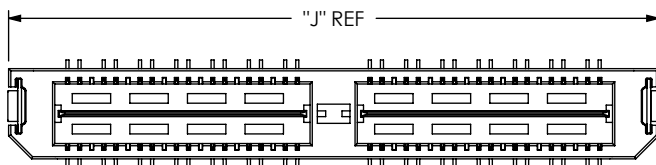

FIG 9
 -RT1: RETENTION OPTION
 (QTE-042-01-XXX-D-DP-A-RT1 SHOWN)
 (DIFFERENT AS SHOWN, OTHERWISE SAME AS FIG 1)
 (ONLY AVAILABLE ON -01 LEAD STYLE) (MUST USE -A OPTION)
 (NOT AVAILABLE WITH -LC, -GP, OR -L OPTIONS)
 (NOT AVAILABLE ON *-056 & *-070 POSITIONS)
 * = SEE NOTES 12 & 15



POS	"J"	"K"	"L"
-014	.906 [23.00]	.915 [23.24]	.854 [21.69]
-028	1.693 [43.00]	1.703 [43.24]	1.642 [41.69]
-042	N/A	N/A	N/A
*-056	N/A	N/A	N/A
*-070	N/A	N/A	N/A

* = SEE NOTES 12 & 15

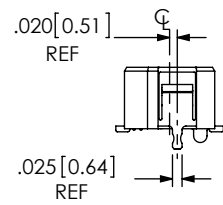
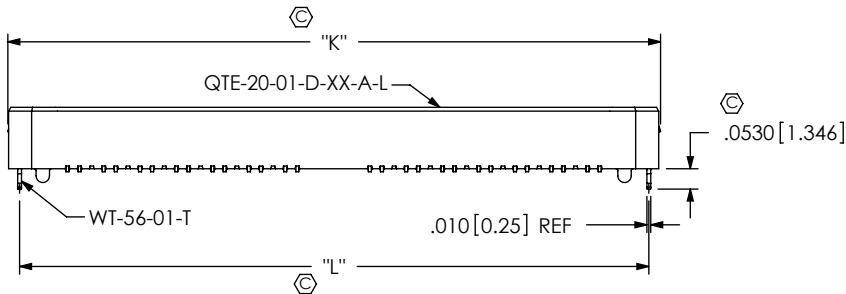

FIG 10
 -L: LATCHING OPTION
 (QTE-028-01-XXX-D-DP-A-L SHOWN)
 (DIFFERENT AS SHOWN, OTHERWISE SAME AS FIG 1)
 (28 POS MAX) (MUST USE -A OPTION)
 (AVAILABLE ON -01 LEAD STYLE ONLY)
 (NOT AVAILABLE WITH -LC, -GP, OR -RT1)

ASSEMBLY OPERATION	IN PROCESS INSPECTION
FILL T-1SXX	C1, C2, C3, C4, C5, C11, C12
ADD -LC OPTION	C13
ADD -RT1 OPTION	C6, C7
ADD -L OPTION	C8, C9, C10
ADD -K OPTION	C14, C15

PROPRIETARY NOTE
 THIS DOCUMENT CONTAINS INFORMATION CONFIDENTIAL AND PROPRIETARY TO SAMTEC, INC. AND SHALL NOT BE REPRODUCED OR TRANSFERRED TO OTHER DOCUMENTS OR DISCLOSED TO OTHERS OR USED FOR ANY PURPOSE OTHER THAN THAT WHICH IT WAS OBTAINED WITHOUT THE EXPRESSED WRITTEN CONSENT OF SAMTEC, INC.
 DO NOT SCALE DRAWING
 SHEET SCALE: 2:1

samtec
 520 PARK EAST BLVD, NEW ALBANY, IN 47150
 PHONE: 812-944-6733 FAX: 812-948-5047
 e-Mail: info@SAMTEC.com code 55322

DESCRIPTION:
 .8mm DIFFERENTIAL PAIRS HS TERMINAL ASSEMBLY

DWG. NO.
QTE-XXX-XX-XXX-D-DP-XXX

BY: DEAN P 4/28/2000 SHEET 5 OF 5