

DO NOT SCALE FROM THIS PRINT

TABLE 1							MATED HEIGHT WITH QSH-01
STYLE	"B"	"C"	BODY (-LC)	BODY (-A)	GROUND PLANE	TERMINAL	
-01	.1680 [4.267]	.1600 [4.064]	QTH-30-01-D-XX	QTH-30-01-D-XX-A	T-1G1-01-X	T-1S39-01-X	.197 [5.00] REF
-02	.2861 [7.267]	.2781 [7.064]	QTH-30-02-D-XX	QTH-30-02-D-XX-A	T-1G1-02-X	T-1S59-02-X	.3150 [8.00] REF

TABLE 2		
POS	"A"	"D"
-030	.788 [20.00]	.728 [18.48]
-060	1.575 [40.01]	1.515 [38.48]
-090	2.363 [60.01]	2.303 [58.48]
-120	3.150 [80.01]	3.090 [78.49]
-150	3.938 [100.01]	3.878 [98.49]

TABLE 3	
No OF POSITIONS	COPLANARITY INCLUDING GROUND PLANE
-030 THRU -060	.004 [0.10]
-090 THRU -150	.006 [0.15]

QTH-XXX-XX-X-D-XXX

No OF POSITIONS
-030, -060, -090,
* -120, * -150 (PER ROW)
* (SEE NOTE 11)

LEAD STYLE
-01: .1680[4.267]
-02: .2861[7.264]
-03: .4043[10.269]
-04: .6001[15.246]
-05: .7181[18.240]
-06: .8361[21.237]
-07: .9542[24.237]
-08: 1.1511[29.238]
-09: .5224[13.269]
-10: .5618[14.269]
□ = SEE TABLE 6, SHT 3

OPTION
-LC: LOCKING CLIPS (USE LC-08-TM-01, SEE FIG 2, SHT 2)
-A: ALIGNMENT PINS (USE QTH-30-XX-D-XX-A FOR -01 & -02) (FOR -03 THRU -10 SEE TABLE 6, SHT 3)
-K: POLYIMIDE FILM (USE K-DOT-276-.375-.005) (AVAILABLE ON -01 THRU -04, -09 & -10 ONLY) (SEE FIG 3, SHT 2)
-TR: TAPE & REEL (-090 POS MAX) (-060 POS MAX W/ -GP OPTION) (N/A ON -05 THRU -08) (SEE FIG 12, SHT 6)
-GP: GUIDE POSTS (AVAILABLE ON -01 & -02 ONLY) (USE QTH-30-XX-D-XX-GP) (SEE FIG 8, SHT 4)
-FL: FRICTION LOCKS (SEE FIG 8, SHT 4) (NOT AVAILABLE WITH -GP)
-RT1: RETENTION OPTION (SEE FIG 10, SHT 5) (ONLY AVAILABLE ON -01 LEAD STYLE) (MUST USE -A OPTION) (USE QTH-30-01-D-XX-A-RT1 & T-1R36-01-F) (NOT AVAILABLE WITH -LC, -GP, OR -FL)
-L: LATCHING OPTION (SEE FIG 11, SHT 5) (ONLY AVAILABLE ON -01 LEAD STYLE) (USE QTH-30-01-D-XX-L) (NOT AVAILABLE WITH -LC, -GP, -FL, OR -RT1) (-060 POS MAX)

PLATING SPECIFICATION

-F: 3 μ" SELECTIVE GOLD IN CONTACT AREA, MATTE TIN ON TAIL (USE T-1SXX-XX-F & T-1GXX-XX-F) (SEE NOTE 7)
-L: 10 μ" SELECTIVE GOLD IN CONTACT AREA, MATTE TIN ON TAIL (USE T-1SXX-XX-L & T-1GXX-XX-L)
-H: 30 μ" GOLD IN CONTACT AREA, 3 μ" GOLD ON TAIL (USE T-1SXX-XX-H & T-1GXX-XX-G)
-C: 50 μ" SELECTIVE GOLD IN CONTACT AREA, MATTE TIN ON TAIL (USE T-1SXX-XX-C, T-1GXX-XX-L)

ROW SPECIFICATION
-D: DOUBLE (USE QTH-30-XX-D-XX & QTHH-30-XX-D-XX)

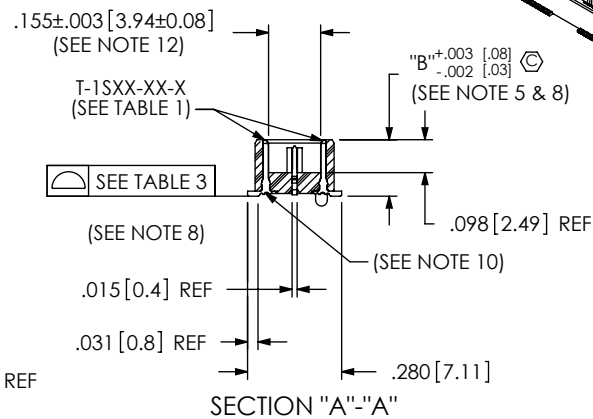
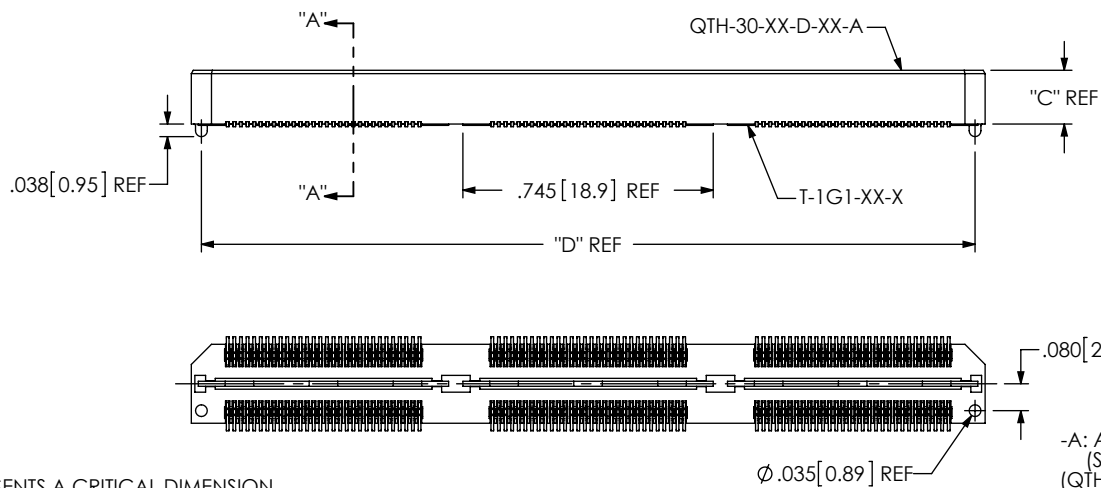
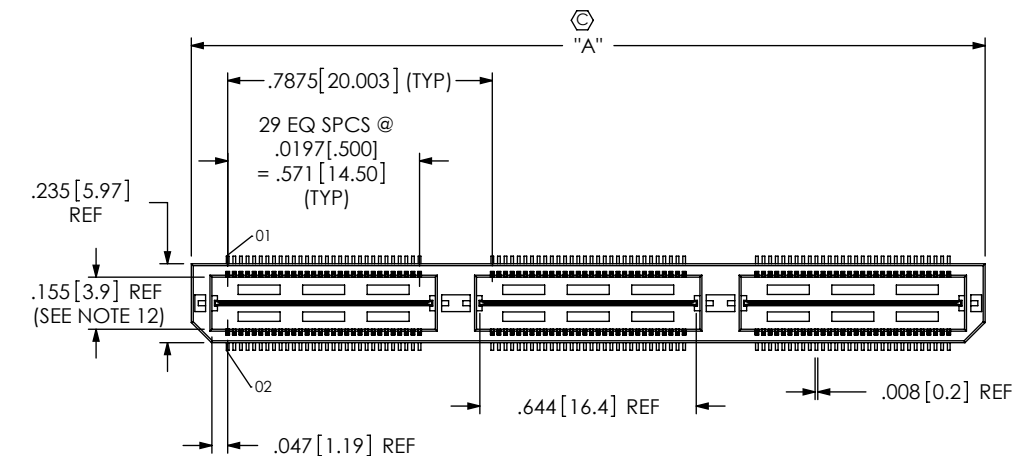

FIG 1
-A: ALIGNMENT PIN OPTION (STYLE -01 & -02 ONLY) (QTH-090-01-X-D-A SHOWN)

- NOTES:
- ① REPRESENTS A CRITICAL DIMENSION.
 - MINIMUM PUSHOUT FORCE: 6 OZ FOR -01 & -02, 8 OZ FOR -03 THRU -10.
 - MINIMUM GROUND PLANE RETENTION: 1 LB.
 - PARTS TO BE MOLDED TO POSITION.
 - MAXIMUM VARIANCE OF .002 [0.05]. APPLIES TO SIGNAL OR GROUNDS INDEPENDENT OF THE GROUND OR SIGNAL PINS RESPECTIVELY.
 - LEAD STYLES -03 THRU -10: TOP BODY (QTH) CANNOT HAVE -A OPTION.
 - L PLATING CAN BE SUBSTITUTED FOR -F PLATING.
 - GROUND PLANE PRESS HEIGHT MUST BE .003 [0.07] LESS THAN THE MAXIMUM HEIGHT OR .002 [0.05] GREATER THAN THE MINIMUM HEIGHT OF SIGNAL PIN.
 - T-1R36 RETENTION TO BODY TO BE 1.0 LBF.
 - CUT OFF BURR NOT TO EXCEED .003 [0.08] IN ANY DIRECTION, BURR PLUS TAB HEIGHT NOT TO EXCEED .006 [0.15].
 - FOR NEW APPLICATIONS REQUIRING THESE POSITIONS, PLEASE CONTACT SAMTEC INTERCONNECT PROCESSING GROUP.
 - PIN CAN EXTEND PAST WALL .003 [0.08] MAX.

UNLESS OTHERWISE SPECIFIED, DIMENSIONS ARE IN INCHES.
TOLERANCES ARE:
DECIMALS ANGLES
.XX: ±.01 [0.3] 2°
.XXX: ±.005 [0.13]
.XXXX: ±.0020 [0.051]

PROPRIETARY NOTE
THIS DOCUMENT CONTAINS INFORMATION CONFIDENTIAL AND PROPRIETARY TO SAMTEC, INC. AND SHALL NOT BE REPRODUCED OR TRANSFERRED TO OTHER DOCUMENTS OR DISCLOSED TO OTHERS OR USED FOR ANY PURPOSE OTHER THAN THAT WHICH IT WAS OBTAINED WITHOUT THE EXPRESSED WRITTEN CONSENT OF SAMTEC, INC.



520 PARK EAST BLVD, NEW ALBANY, IN 47150
PHONE: 812-944-6733 FAX: 812-948-5047
e-Mail: info@SAMTEC.com code 55322

MATERIAL: DO NOT SCALE DRAWING SHEET SCALE: 1.75:1
INSULATOR: LCP UL94V-0, COLOR: BLACK
TERMINAL & GROUND PLANE: PHOS BRONZE

DESCRIPTION: .5mm DOUBLE ROW HS TERMINAL ASSEMBLY
DWG. NO. QTH-XXX-XX-X-D-XXX

FIG 2
-LC LOCKING CLIP OPTION
(QTH-090-01-X-D-LC SHOWN)
(SAME AS FIG 1, EXCEPT AS SHOWN)

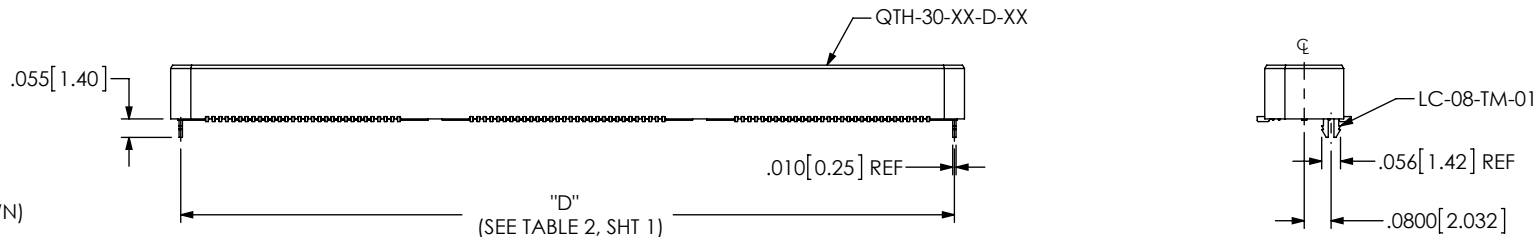
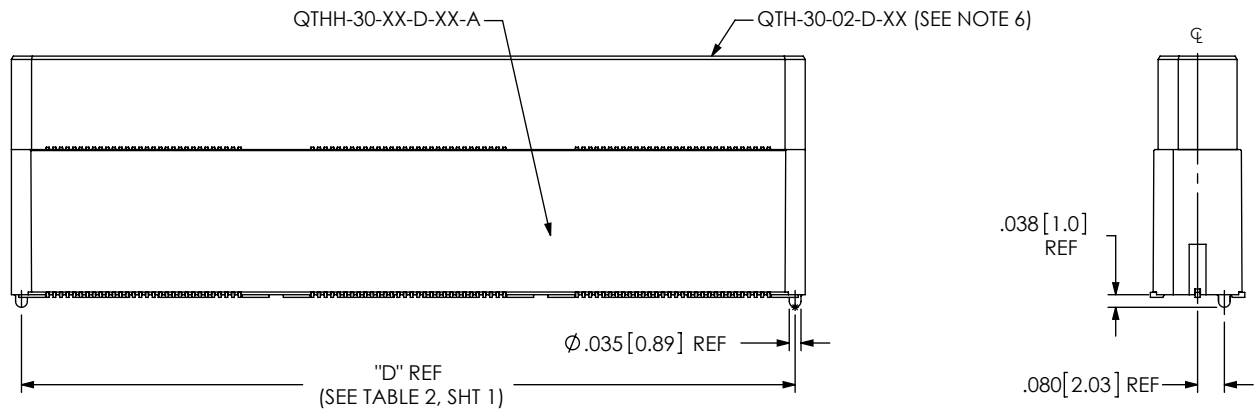

FIG 3
-A: ALIGNMENT PIN OPTION
(QTH-090-05-X-D-A SHOWN)
(SAME AS FIG 1, EXCEPT AS SHOWN)
(STYLES -03 THRU -09, SEE TABLE 6, SHT 3)



No OF POS	"R"				"S"			
	-LC, -A, -FL	-GP	-RT1	-L	-LC, -A, -FL	-GP	-RT1	-L
-030	.788 [20.00]	1.305 [33.15]	1.438 [36.53]	.906 [23.00]	.256 [6.50]	.515 [13.07]	.581 [14.76]	.315 [7.99]
-060	1.575 [40.01]	2.093 [53.15]	2.226 [56.53]	1.693 [43.00]	.650 [16.50]	.908 [23.07]	.975 [24.76]	.709 [18.00]
-090	2.363 [60.01]	2.880 [73.15]	3.013 [76.53]	2.481 [63.00]	1.043 [26.50]	1.302 [33.07]	1.369 [34.76]	1.102 [28.00]
-120	3.150 [80.01]	3.668 [93.15]	3.801 [96.53]	3.268 [83.01]	1.437 [36.50]	1.696 [43.07]	1.762 [44.76]	1.496 [38.00]
-150	3.938 [100.01]	4.455 [113.16]	4.588 [116.54]	4.056 [103.01]	1.831 [46.50]	2.090 [53.07]	2.156 [54.76]	1.890 [48.00]

STYLE	"T"
-01	.173 [4.39]
-02	.290 [7.37]
-03	.409 [10.39]
-04	.605 [15.37]
-09	.527 [13.39]
-10	.566 [14.38]

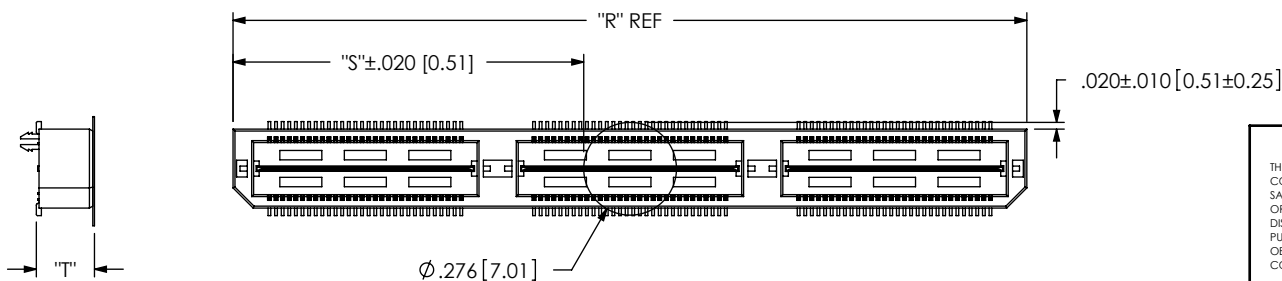

FIG 4
-K: POLYIMIDE FILM PAD OPTION
(USE K-DOT-.276-.375-.005)

PROPRIETARY NOTE

THIS DOCUMENT CONTAINS INFORMATION CONFIDENTIAL AND PROPRIETARY TO SAMTEC, INC. AND SHALL NOT BE REPRODUCED OR TRANSFERRED TO OTHER DOCUMENTS OR DISCLOSED TO OTHERS OR USED FOR ANY PURPOSE OTHER THAN THAT WHICH IT WAS OBTAINED WITHOUT THE EXPRESSED WRITTEN CONSENT OF SAMTEC, INC.

DO NOT SCALE DRAWING

SHEET SCALE: 1:75:1



520 PARK EAST BLVD, NEW ALBANY, IN 47150
PHONE: 812-944-6733 FAX: 812-948-5047
e-Mail: info@SAMTEC.com code 55322

DESCRIPTION:
.5mm DOUBLE ROW HS TERMINAL ASSEMBLY

DWG. NO. QTH-XXX-XX-X-D-XXX

BY: DEAN P 09-14-2010 SHEET 2 OF 6

REVISION BE

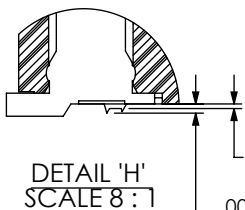

		TABLE 6							MATED HEIGHT WITH QSH-01
STYLE	SEE FIGURE	"E" OVERALL HEIGHT	GROUND PLANE	TERMINAL	TOP BODY (SEE NOTE 6)	BOTTOM SPACER BODY (-LC OR NONE)	BOTTOM SPACER BODY (-A)		
-03	5	.4043 [10.269]	T-1G1-03-X	T-1S60-03-X	QTH-30-02-D-XX	QTHH-30-01-D-XX	QTHH-30-01-D-XX-A	.433 [11.00] REF	
-04	5	.6001 [15.243]	T-1G1-04-X	T-1S60-04-X	QTH-30-02-D-XX	QTHH-30-01-D-XX	QTHH-30-01-D-XX-A	.630 [16.00] REF	
-05	6	.7181 [18.240]	T-1G1-05-X	T-1S60-05-X	QTH-30-02-D-XX	QTHH-30-03-D-XX	QTHH-30-03-D-XX-A	.748 [19.00] REF	
-06	6	.8361 [21.237]	T-1G1-06-X	T-1S60-06-X	QTH-30-02-D-XX	QTHH-30-03-D-XX	QTHH-30-03-D-XX-A	.866 [22.00] REF	
-07	7	.9542 [24.237]	T-1G1-07-1-X	T-1S61-21-X	QTH-30-02-D-XX	QTHH-30-04-D-XX	QTHH-30-04-D-XX-A	.984 [24.99] REF	
-08	7	1.1511 [29.238]	T-1G1-07-2-X	T-1S61-22-X	QTH-30-02-D-XX	QTHH-30-04-D-XX	QTHH-30-04-D-XX-A	1.181 [30.00] REF	
-09	5	.5224 [13.269]	T-1G1-09-X	T-1S60-09-X	QTH-30-02-D-XX	QTHH-30-01-D-XX	QTHH-30-01-D-XX-A	.551 [14.00] REF	
-10	5	.5618 [14.270]	T-1G1-10-X	T-1S60-10-X	QTH-30-02-D-XX	QTHH-30-01-D-XX	QTHH-30-01-D-XX-A	.591 [15.01] REF	

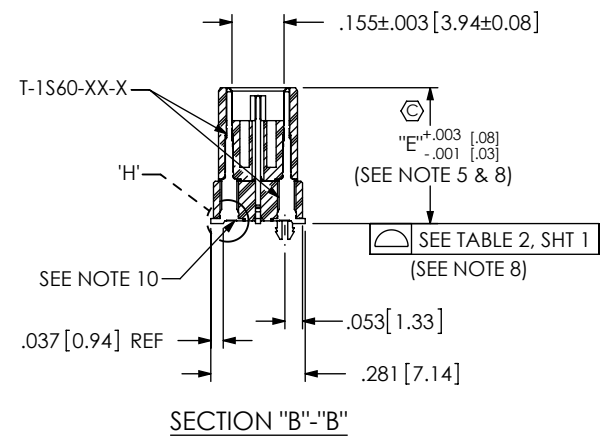
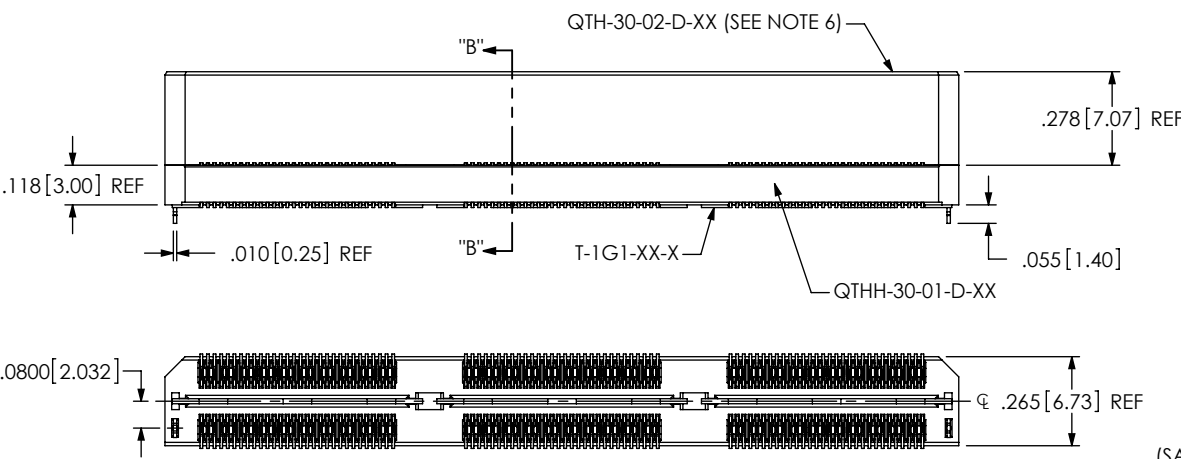

FIG 5
(QTH-090-03-X-D-LC SHOWN)
(SAME AS FIG 1, EXCEPT AS SHOWN)

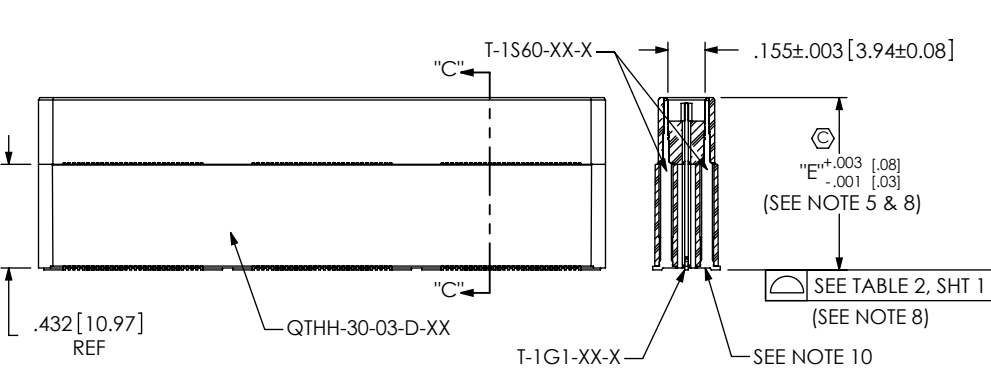

FIG 6
(QTH-090-05-X-D SHOWN)
(SAME AS FIG 5, EXCEPT AS SHOWN)

SECTION "C"-"C"
SCALE 1.25 : 1

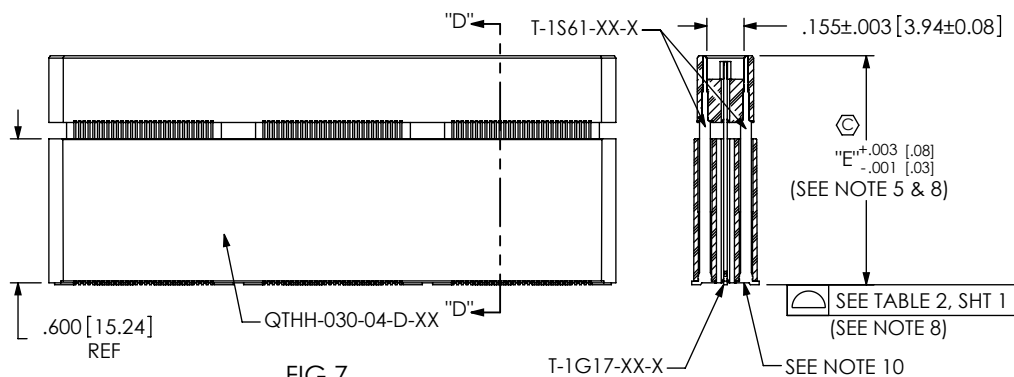

FIG 7
(QTH-090-07-X-D SHOWN)
(SAME AS FIG 5, EXCEPT AS SHOWN)

SECTION "D"-"D"
SCALE 1.25 : 1

PROPRIETARY NOTE
THIS DOCUMENT CONTAINS INFORMATION CONFIDENTIAL AND PROPRIETARY TO SAMTEC, INC. AND SHALL NOT BE REPRODUCED OR TRANSFERRED TO OTHER DOCUMENTS OR DISCLOSED TO OTHERS OR USED FOR ANY PURPOSE OTHER THAN THAT WHICH IT WAS OBTAINED WITHOUT THE EXPRESSED WRITTEN CONSENT OF SAMTEC, INC.

samtec
520 PARK EAST BLVD, NEW ALBANY, IN 47150
PHONE: 812-944-6733 FAX: 812-948-5047
e-Mail: info@SAMTEC.com code 55322

DO NOT SCALE DRAWING
SHEET SCALE: 1:0.571429

DESCRIPTION:
.5mm DOUBLE ROW HS TERMINAL ASSEMBLY
DWG. NO. QTH-XXX-XX-X-D-XXX

TABLE 7		
POS	"F"	"G"
-030	1.305 [33.15]	1.013 [25.72]
-060	2.093 [53.15]	1.800 [45.72]
-090	2.880 [73.15]	2.588 [65.72]
-120	3.668 [93.15]	3.375 [85.73]
-150	4.455 [113.16]	4.163 [105.73]

TABLE 8		
STYLE	"H"	BODY
-01	.3630 [9.220]	QTH-30-01-D-XX-X-GP
-02	.4810 [12.217]	QTH-30-02-D-XX-X-GP

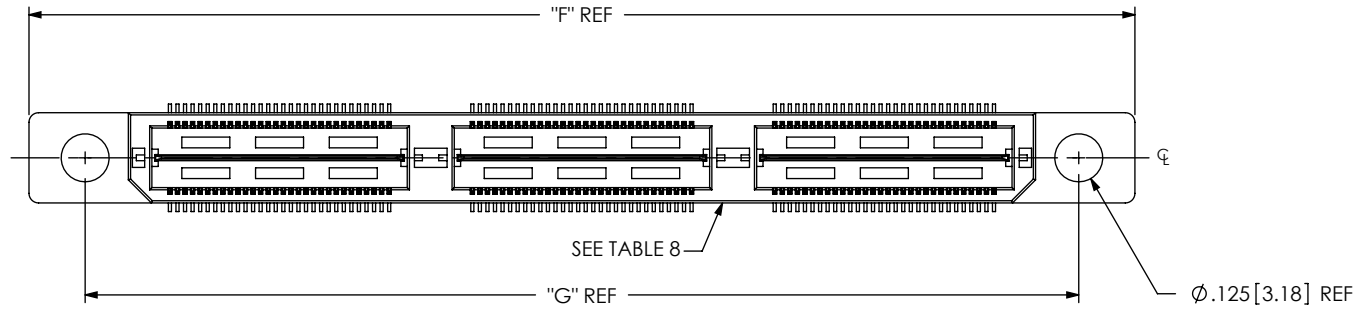

FIG 8
(QTH-090-01-X-D-GP SHOWN)
(SAME AS FIG 1, EXCEPT AS SHOWN)
(AVAILABLE ON -01 & -02 ONLY)

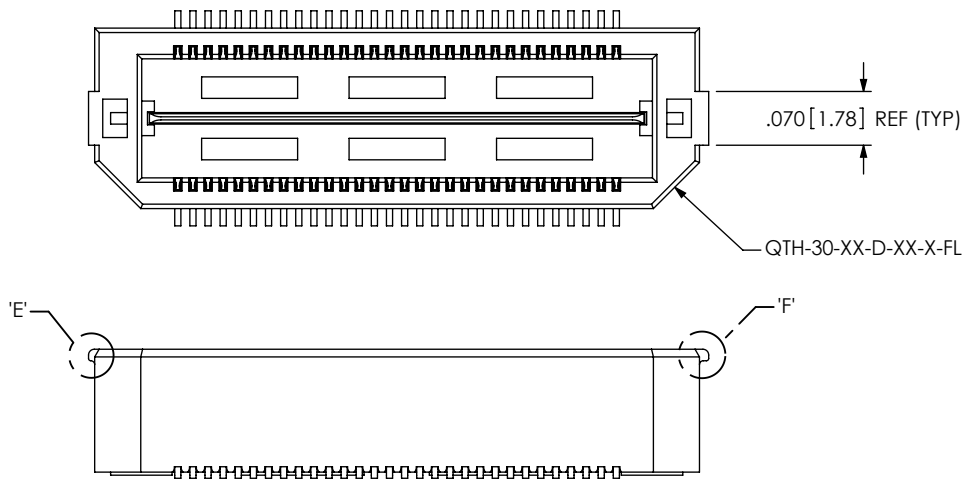
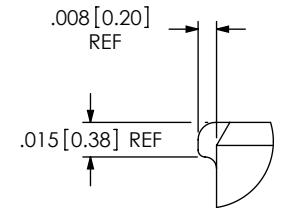
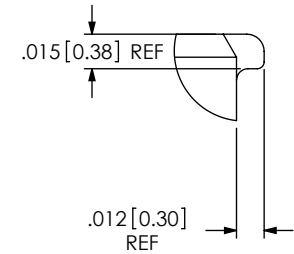

FIG 9
-FL: FRICTION LOCKS
(NOT AVAILABLE WITH -GP OPTION)
(SAME AS FIG 1, EXCEPT AS SHOWN)



DETAIL 'E'
SCALE 12:1



DETAIL 'F'
SCALE 12:1

PROPRIETARY NOTE
THIS DOCUMENT CONTAINS INFORMATION
CONFIDENTIAL AND PROPRIETARY TO
SAMTEC, INC. AND SHALL NOT BE REPRODUCED
OR TRANSFERRED TO OTHER DOCUMENTS OR
DISCLOSED TO OTHERS OR USED FOR ANY
PURPOSE OTHER THAN THAT WHICH IT WAS
OBTAINED WITHOUT THE EXPRESSED WRITTEN
CONSENT OF SAMTEC, INC.

DO NOT SCALE DRAWING

SHEET SCALE: 2:1

samtec

520 PARK EAST BLVD, NEW ALBANY, IN 47150
PHONE: 812-944-6733 FAX: 812-948-5047
e-Mail: info@SAMTEC.com code 55322

DESCRIPTION:
.5mm DOUBLE ROW HS TERMINAL ASSEMBLY

DWG. NO. QTH-XXX-XX-X-D-XXX

BY: DEAN P 09-14-2010 SHEET 4 OF 6

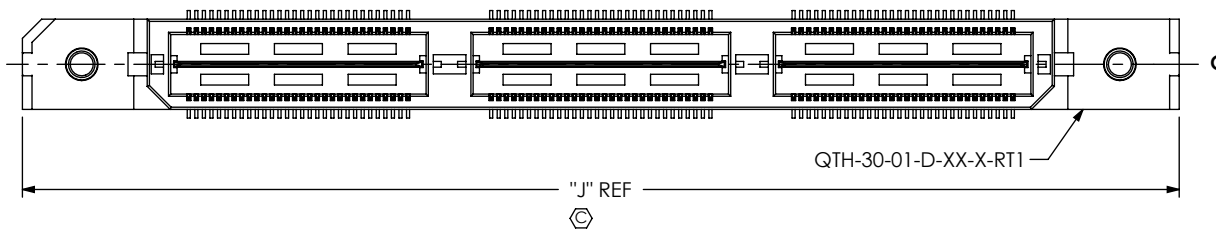

POS	"J"	"K"
-030	1.438 [36.53]	1.129 [28.68]
-060	2.226 [56.53]	1.917 [48.68]
-090	3.013 [76.53]	2.704 [68.68]
-120	3.801 [96.53]	3.492 [88.68]
-150	4.588 [116.54]	4.279 [108.69]

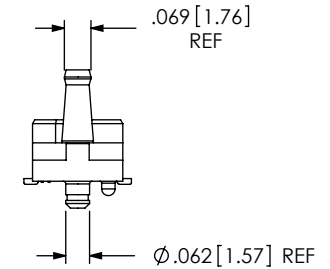
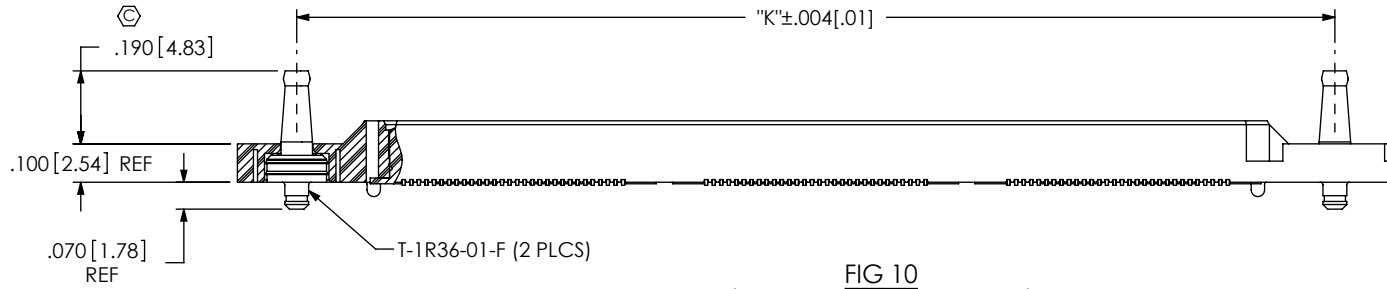
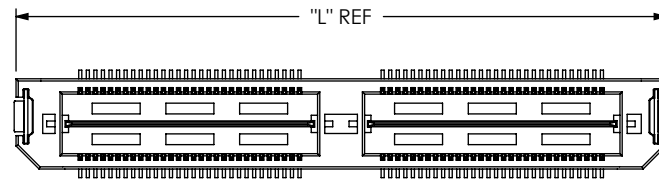

FIG 10
 (QTH-090-01-X-D-A-RT1 SHOWN)
 (NOT AVAILABLE WITH -LC, -GP, OR -FL OPTIONS)
 (AVAILABLE ON -01 ONLY)
 (SAME AS FIG 1, EXCEPT AS SHOWN)



POS	"L"	"M"	"N"
-030	.906 [23.00]	.915 [23.24]	.854 [21.69]
-060	1.693 [43.00]	1.703 [43.24]	1.642 [41.69]
*-090	2.481 [63.00]	2.490 [63.25]	2.429 [61.70]

(* = NOT RELEASED)

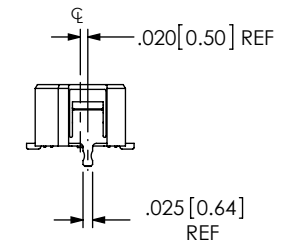
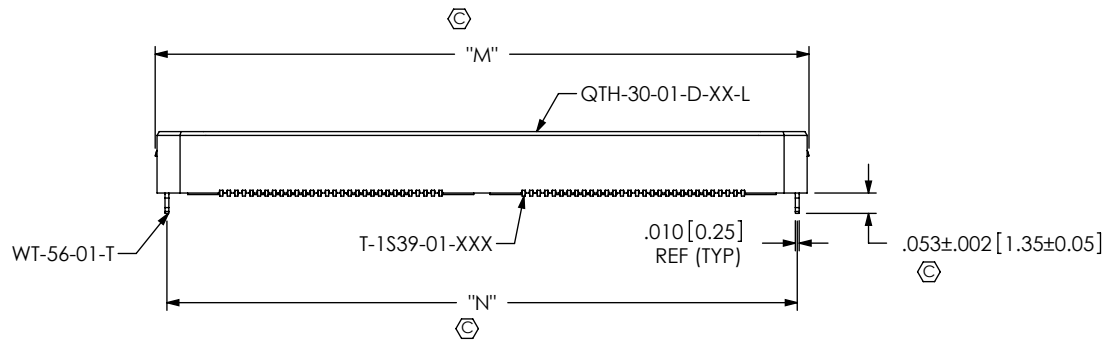

FIG 11
 L: LATCHING OPTION
 (QTH-060-01-X-D-L SHOWN)
 (AVAILABLE ON -01 LEAD STYLE ONLY)
 (NOT AVAILABLE WITH -LC, -GP, -FL, OR -RT1 OPTIONS)
 (SAME AS FIG 1, EXCEPT AS SHOWN)

PROPRIETARY NOTE
 THIS DOCUMENT CONTAINS INFORMATION
 CONFIDENTIAL AND PROPRIETARY TO
 SAMTEC, INC. AND SHALL NOT BE REPRODUCED
 OR TRANSFERRED TO OTHER DOCUMENTS OR
 DISCLOSED TO OTHERS OR USED FOR ANY
 PURPOSE OTHER THAN THAT WHICH IT WAS
 OBTAINED WITHOUT THE EXPRESSED WRITTEN
 CONSENT OF SAMTEC, INC.

DO NOT SCALE DRAWING

SHEET SCALE: 2:1

samtec

520 PARK EAST BLVD. NEW ALBANY, IN 47150
 PHONE: 812-944-6733 FAX: 812-948-5047
 e-Mail: info@SAMTEC.com code 55322

DESCRIPTION:
 .5mm DOUBLE ROW HS TERMINAL ASSEMBLY

DWG. NO. QTH-XXX-XX-X-D-XXX

BY: DEAN P 09-14-2010 SHEET 5 OF 6

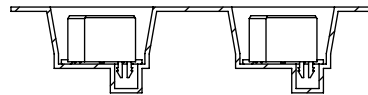
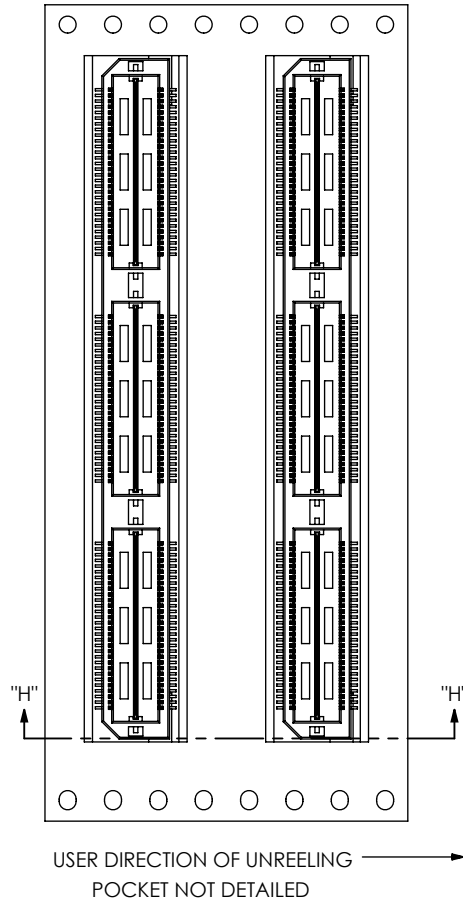

SECTION "H"-"H"
SCALE 1.5 : 1

FIG 12
-TR: TAPE & REEL
(QTH-090-01-X-D-LC-TR SHOWN)
(-090 POS MAX)
(-060 POS MAX W/-GP OPTION)
(N/A ON -05 THRU -08)
(SAME AS FIG 1, EXCEPT AS SHOWN)

<p>PROPRIETARY NOTE</p> <p>THIS DOCUMENT CONTAINS INFORMATION CONFIDENTIAL AND PROPRIETARY TO SAMTEC, INC. AND SHALL NOT BE REPRODUCED OR TRANSFERRED TO OTHER DOCUMENTS OR DISCLOSED TO OTHERS OR USED FOR ANY PURPOSE OTHER THAN THAT WHICH IT WAS OBTAINED WITHOUT THE EXPRESSED WRITTEN CONSENT OF SAMTEC, INC.</p> <p>DO NOT SCALE DRAWING</p> <p>SHEET SCALE: 1:1</p>	 <p>520 PARK EAST BLVD, NEW ALBANY, IN 47150 PHONE: 812-944-6733 FAX: 812-948-5047 e-Mail: info@SAMTEC.com code 55322</p>
	<p>DESCRIPTION: .5mm DOUBLE ROW HS TERMINAL ASSEMBLY</p> <p>DWG. NO. QTH-XXX-XX-X-D-XXX</p>
	<p>BY: DEAN P 09-14-2010 SHEET 6 OF 6</p>