

SECTION "A"- "A"  
SCALE 6:1

**TABLE 6**

POSITION	COPLANARITY
-10 TO -30	.006 [0.15]
-40	.009 [0.23]
-50	.009 [0.23]

**TABLE 7**

LEAD STYLE	"H"	"J"	"K"
-05.0	.0530 - .0590 [1.346] - [1.499]	.0410 - .0470 [1.041] - [1.194]	.011 [0.28]
-06.0	.0530 - .0620 [1.346] - [1.575]	.0380 - .0470 [1.041] - [1.194]	.011 [0.28]
-06.5	.0530 - .0645 [1.346] - [1.638]	.0355 - .0470 [1.041] - [1.194]	.011 [0.28]
*** -07.5	.0530 - .0645 [1.346] - [1.638]	.0355 - .0470 [1.041] - [1.194]	.011 [0.28]

(\*\*\*= NOT TOOLED)

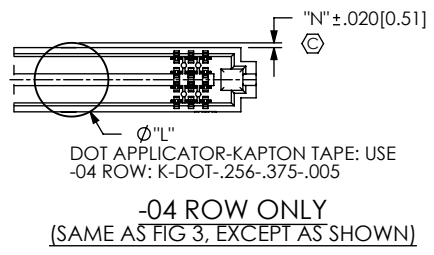
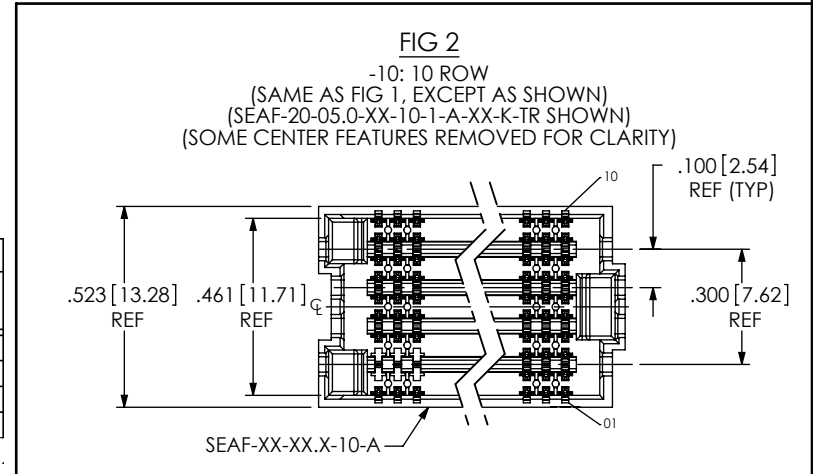

**TABLE 8**

ROWS	"L"	"M"								"N"
		□ 10 POS	⊠ 15 POS	** 19 POS	20 POS	∇ 25 POS	30 POS	40 POS	50 POS	
-04	.256 [6.50]	.254 [6.44]	.379 [9.62]	.479 [12.16]	.504 [12.79]	.629 [15.97]	.754 [19.14]	1.004 [25.49]	1.254 [31.84]	.017 [.43]
-05, -06	.256 [6.50]	.254 [6.44]	.379 [9.62]	.479 [12.16]	.504 [12.79]	.629 [15.97]	.754 [19.14]	1.004 [25.49]	1.254 [31.84]	.034 [.86]
-08	.325 [8.25]	.219 [5.57]	.344 [8.74]	.444 [11.28]	.469 [11.92]	.594 [15.09]	.719 [18.27]	.969 [24.62]	1.219 [30.97]	.049 [1.24]
-10	.404 [10.25]	.180 [4.57]	.305 [7.74]	.405 [10.28]	.430 [10.92]	.555 [14.09]	.680 [17.27]	.930 [23.62]	1.180 [29.97]	.060 [1.52]

**FIG 3**  
-K: POLYIMIDE PAD  
(SEAF-20-05.0-XX-08-1-A-XX-K-TR SHOWN)  
(SAME AS FIG. 1, EXCEPT AS SHOWN)  
(SOME CENTER FEATURES REMOVED FOR CLARITY)

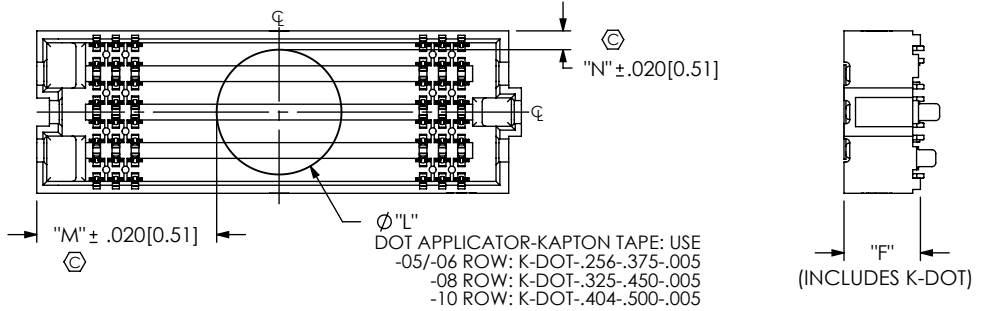

<p><b>PROPRIETARY NOTE</b> THIS DOCUMENT CONTAINS INFORMATION CONFIDENTIAL AND PROPRIETARY TO SAMTEC, INC. AND SHALL NOT BE REPRODUCED OR TRANSFERRED TO OTHER DOCUMENTS OR DISCLOSED TO OTHERS OR USED FOR ANY PURPOSE OTHER THAN THAT WHICH IT WAS OBTAINED WITHOUT THE EXPRESSED WRITTEN CONSENT OF SAMTEC, INC.</p> <p>DO NOT SCALE DRAWING</p> <p>SHEET SCALE: 2:1</p>	<p>520 PARK EAST BLVD. NEW ALBANY, IN 47150 PHONE: 812-944-6733 FAX: 812-948-5047 e-Mail: info@SAMTEC.com code 55322</p>
	<p>DESCRIPTION: .050 PITCH SOCKET ARRAY ASSEMBLY</p>
	<p>DWG. NO. SEAF-XX-XX.X-XX-XX-X-A-XX-K-TR</p>
	<p>BY: BRATCHER 05/27/2004 SHEET 2 OF 5</p>

FIG 4  
 -06: 6 ROW  
 (SAME AS FIG 1, EXCEPT AS SHOWN)  
 (SEAF-20-05.0-XX-06-1-A-XX-K-TR SHOWN)  
 (SOME CENTER FEATURES REMOVED FOR CLARITY)

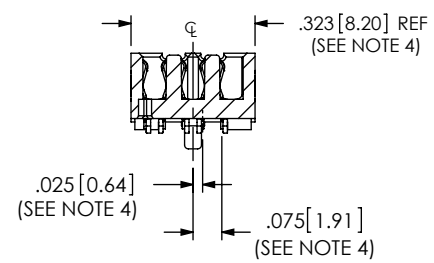
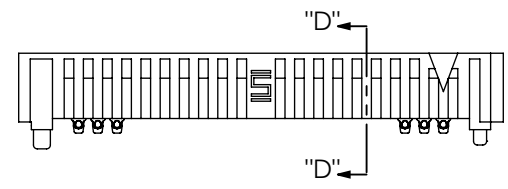
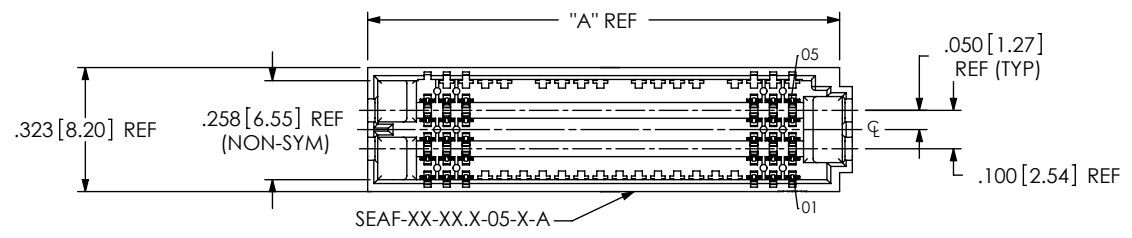
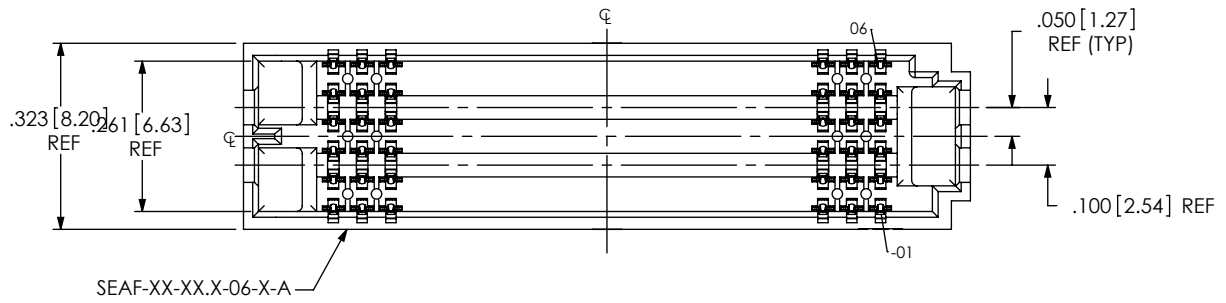

SECTION "D"-D"

FIG 5  
 -05: 5 ROW  
 (SAME AS FIG 4, EXCEPT AS SHOWN)  
 (SEAF-20-05.0-XX-05-1-A-XX-K-TR SHOWN)  
 (SOME CENTER FEATURES REMOVED FOR CLARITY)

<p>PROPRIETARY NOTE                  THIS DOCUMENT CONTAINS INFORMATION CONFIDENTIAL AND PROPRIETARY TO SAMTEC, INC. AND SHALL NOT BE REPRODUCED OR TRANSFERRED TO OTHER DOCUMENTS OR DISCLOSED TO OTHERS OR USED FOR ANY PURPOSE OTHER THAN THAT WHICH IT WAS OBTAINED WITHOUT THE EXPRESSED WRITTEN CONSENT OF SAMTEC, INC.</p> <p>DO NOT SCALE DRAWING</p> <p>SHEET SCALE: 1:0.333333</p>		
	<p>520 PARK EAST BLVD, NEW ALBANY, IN 47150                  PHONE: 812-944-6733 FAX: 812-948-5047                  e-Mail info@SAMTEC.com code 55322</p>	
	<p>DESCRIPTION:                  .050 PITCH SOCKET ARRAY ASSEMBLY</p>	
	<p>DWG. NO.                  SEAF-XX-XX.X-XX-XX-X-A-XX-K-TR</p>	
<p>BY: BRATCHER 05/27/2004</p>		<p>SHEET 3 OF 5</p>

**FIG 7**  
 06 ROW x 19 POS.  
 (SEE NOTE 12)  
 (ONLY AVAILABLE -06.5 LEADSTYLE & -06 ROW)  
 (SEAF-20-06.5-XX-06-1-XX-K-TR SHOWN)  
 (SAME AS FIGS 1 & 4 EXCEPT AS SHOWN)  
 (SOME CENTER FEATURES REMOVED FOR CLARITY)

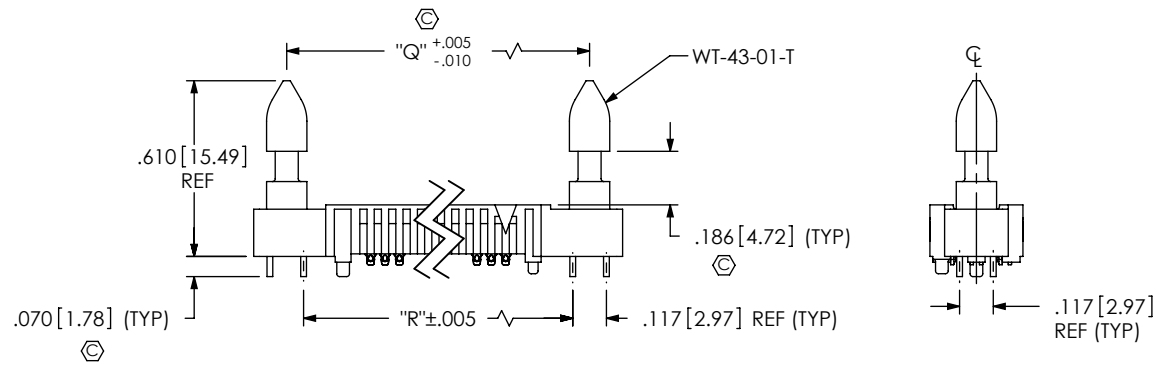
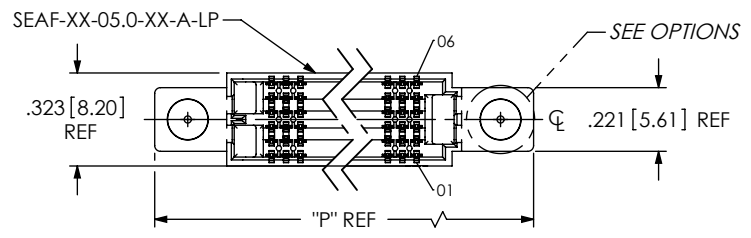
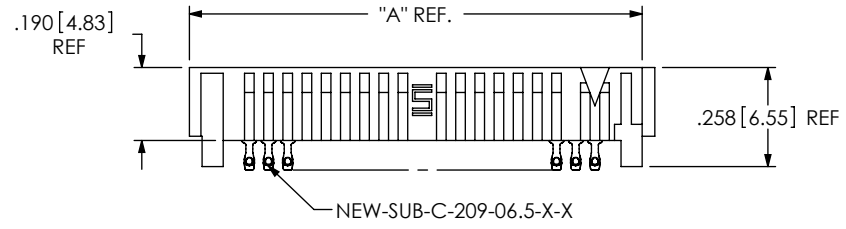
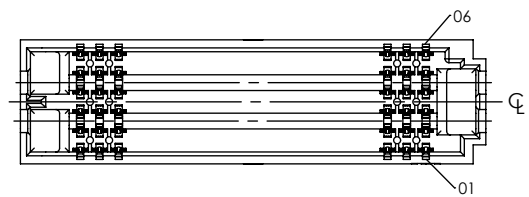

**FIG 8**  
 -LP OPTION  
 (SEAF-20-05.0-XX-06-1-A-LP-K-TR SHOWN)  
 (SOME CENTER FEATURES REMOVED FOR CLARITY)  
 (SAME AS FIG 6 EXCEPT AS SHOWN)  
 (-LP OPTION REQUIRED FOR SEAC MATE ONLY)  
 (ONLY AVAILABLE WITH -05.0 LEAD STYLE -04, -06, -08 & -10 ROW)

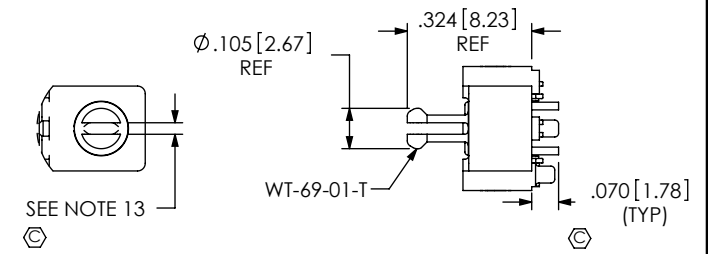

**FIG 9**  
 \*\*\*\*\*RP OPTION  
 (SEAF-20-05.0-XX-06-1-A-RP-K-TR SHOWN)  
 (SOME CENTER FEATURES REMOVED FOR CLARITY)  
 (SAME AS FIG 7 EXCEPT AS SHOWN)  
 (-RP OPTION VALID FOR SEAR MATE ONLY)  
 (ONLY AVAILABLE WITH -05.0 LEAD STYLE 6, 8 & 10 ROW)

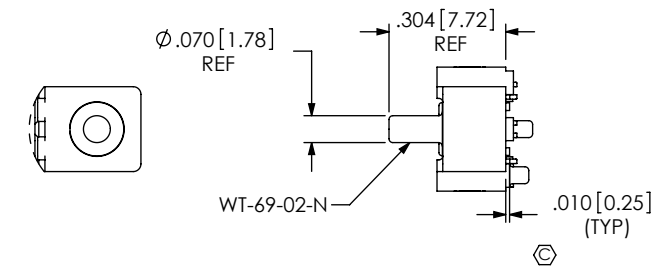

**FIG 10**  
 -PP OPTION  
 (SEAF-20-05.0-XX-06-1-A-PP-K-TR SHOWN)  
 (SOME CENTER FEATURES REMOVED FOR CLARITY)  
 (SAME AS FIG 7 EXCEPT AS SHOWN)  
 (-PP OPTION VALID FOR SEAR MATE ONLY)  
 (ONLY AVAILABLE WITH -05.0 LEAD STYLE 6, 8 & 10 ROW)

**TABLE 9**

No OF POS.	"P"	"Q"	"R"
□ -10	1.262 [32.05]	1.033 [26.24]	.9160 [23.266]
⊠ -15	1.512 [38.40]	1.283 [32.59]	1.1660 [29.616]
** -19	1.712 [43.48]	1.483 [37.67]	1.3660 [34.696]
-20	1.762 [44.75]	1.533 [38.94]	1.4160 [35.966]
▤ -25	2.012 [51.10]	1.783 [45.29]	1.6660 [42.316]
-30	2.262 [57.45]	2.033 [51.64]	1.9160 [48.666]
-40	2.762 [70.15]	2.533 [64.34]	2.4160 [61.366]
-50	3.262 [82.85]	3.033 [77.04]	2.9160 [74.066]

**PROPRIETARY NOTE**  
 THIS DOCUMENT CONTAINS INFORMATION CONFIDENTIAL AND PROPRIETARY TO SAMTEC, INC. AND SHALL NOT BE REPRODUCED OR TRANSFERRED TO OTHER DOCUMENTS OR DISCLOSED TO OTHERS OR USED FOR ANY PURPOSE OTHER THAN THAT WHICH IT WAS OBTAINED WITHOUT THE EXPRESSED WRITTEN CONSENT OF SAMTEC, INC.

DO NOT SCALE DRAWING

SHEET SCALE: 1:0.333333

520 PARK EAST BLVD. NEW ALBANY, IN 47150  
 PHONE: 812-944-6733 FAX: 812-948-5047  
 e-Mail: info@SAMTEC.com code 55322

DESCRIPTION:  
 .050 PITCH SOCKET ARRAY ASSEMBLY

DWG. NO.  
**SEAF-XX-XX.X-XX-XX-X-A-XX-K-TR**

BY: BRATCHER 05/27/2004 SHEET 4 OF 5

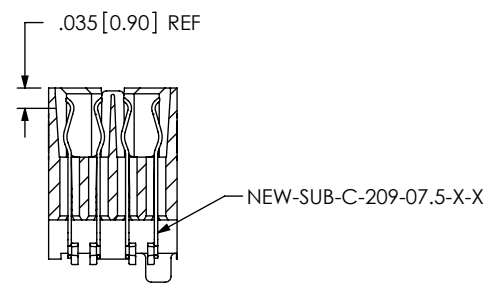
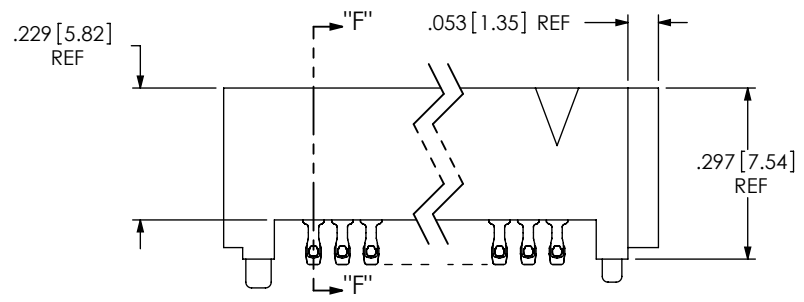
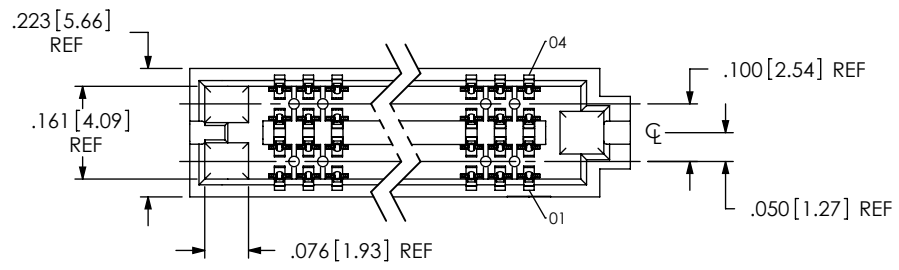

SECTION "F"-"F"

FIG 11  
 -04: 4 ROW  
 (SEAF-30-07.5-XX-04-1-A-XX-K-TR SHOWN)  
 (SOME CENTER FEATURES REMOVED FOR CLARITY)  
 (SAME AS FIG 1 EXCEPT AS SHOWN )

<p>PROPRIETARY NOTE</p> <p>THIS DOCUMENT CONTAINS INFORMATION CONFIDENTIAL AND PROPRIETARY TO SAMTEC, INC. AND SHALL NOT BE REPRODUCED OR TRANSFERRED TO OTHER DOCUMENTS OR DISCLOSED TO OTHERS OR USED FOR ANY PURPOSE OTHER THAN THAT WHICH IT WAS OBTAINED WITHOUT THE EXPRESSED WRITTEN CONSENT OF SAMTEC, INC.</p> <p>DO NOT SCALE DRAWING</p> <p>SHEET SCALE: 1:0.333333</p>		
	<p>520 PARK EAST BLVD, NEW ALBANY, IN 47150                  PHONE: 812-944-6733 FAX: 812-948-5047                  e-Mail info@SAMTEC.com code 55322</p>	
	<p>DESCRIPTION:                  .050 PITCH SOCKET ARRAY ASSEMBLY</p>	
	<p>DWG. NO.                  SEAF-XX-XX.X-XX-XX-X-A-XX-K-TR</p>	
<p>BY: BRATCHER 05/27/2004</p>		<p>SHEET 5 OF 5</p>