

DO NOT SCALE FROM THIS PRINT

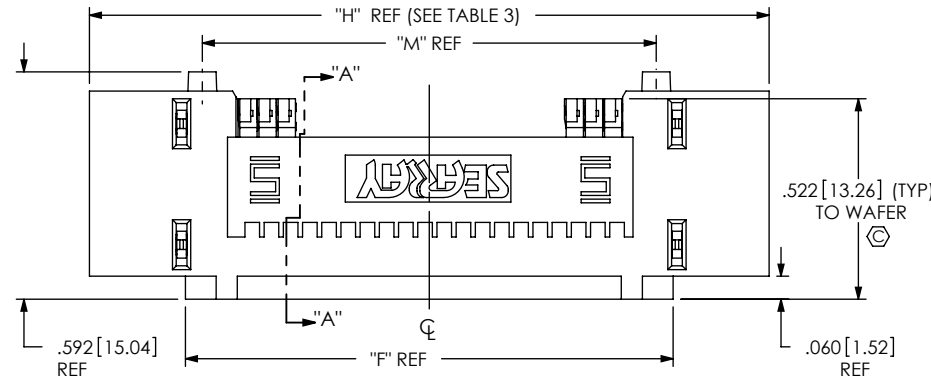

SEAF-XX-XX-X-XX-X-RA-XX-TR

No. OF POSITIONS
-20, -30, -40, -50 (PER ROW)

LEAD STYLE
-01

PLATING SPECIFICATION
-S: SELECTIVE GOLD, 30μ GOLD, MATTE TIN ON TAILS (USE SUB-IM-C-242-XX-S-X)
-L: LIGHT SELECTIVE GOLD, 10μ GOLD, MATTE TIN ON TAILS (USE SUB-IM-C-242-XX-L-X)

No. OF ROWS
-04, *-06, *-08, *-10 (* = SEE NOTE 8)

PACKAGING
-TR: TAPE & REEL (STANDARD PACKAGING) (SEE NOTE 4 & 7)

OPTIONS
-GP: GUIDE POST HOLE
-LP: LATCH POST (USE WITH SEAC ONLY) (-06 ROW ONLY) (NOT AVAILABLE WITH -GP OPTION)
-K: KAPTON PAD

RIGHT ANGLE
-RA

SOLDER COMPOSITION & STYLE
-T1: 63% TIN / 37% LEAD CHARGE TAIL (USE SUB-IM-C-242-XX-XX-X-1)
-2: 95.5% TIN / 3.8 SILVER / 0.7% COPPER LEAD FREE CHARGE TAIL (USE SUB-IM-C-242-XX-XX-X-2)

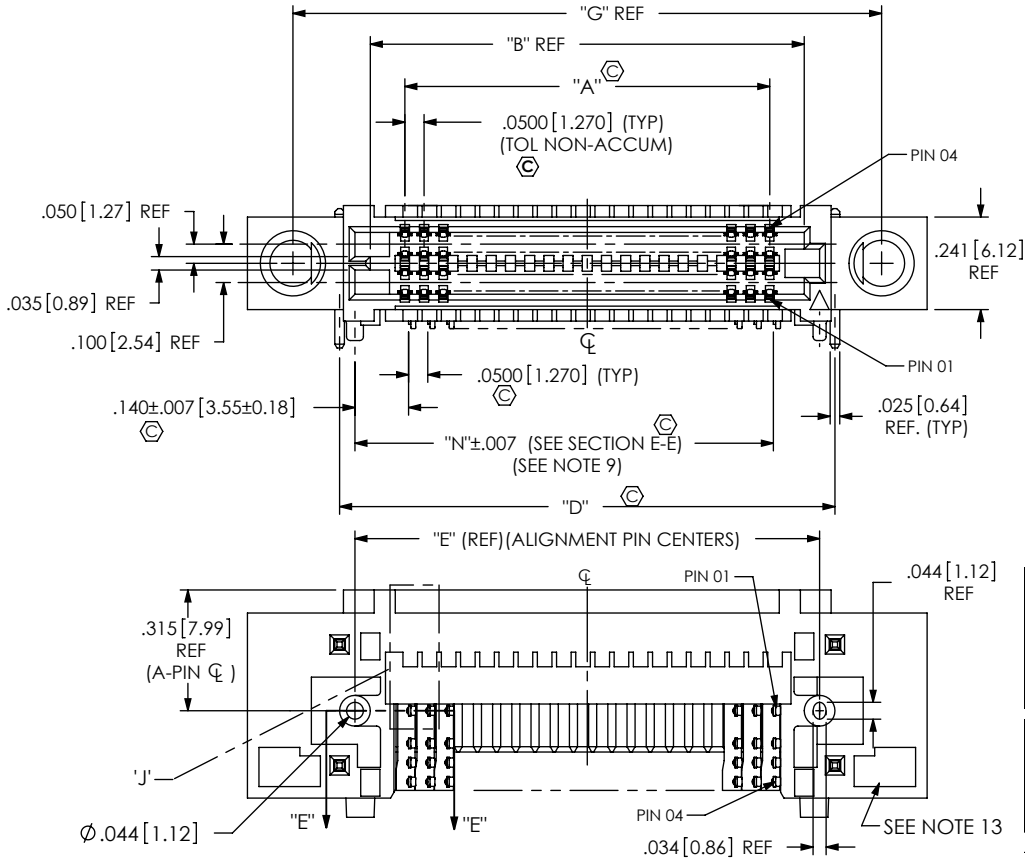

TABLE 3

STYLE	No. OF POS PER ROW	"G"	"H"	"J"	
STANDARD WITH -GP OPTION	-20	1.533 [38.94]	1.770 [44.96]	N/A	
	-30	2.033 [51.64]	2.270 [57.66]		
	-40	2.533 [64.34]	2.770 [70.36]		
	-50	3.033 [77.04]	3.270 [83.06]		
WITHOUT -GP OPTION	-20	N/A	1.370 [34.80]		
	-30	N/A	1.870 [47.50]		
	-40	N/A	2.370 [60.20]		
	-50	N/A	2.870 [72.90]		
WITH-LP OPTION	-20	1.533 [38.94]	1.900 [48.26]		1.790 [45.47]
	-30	2.033 [51.64]	2.400 [60.96]		2.290 [58.17]
	-40	2.533 [64.34]	2.900 [73.66]	2.790 [70.10]	
	-50	3.033 [77.04]	3.400 [86.36]	3.290 [83.57]	

TABLE 2

No. OF ROWS	"BODY CALLOUT"	"SOCKET WAFER"	"WELD TAB"	"C"
-04	SEAF-XX-01-RA-04-XX	SUB-IM-C-242-01-04-X-X	WT-28-01-T	0.315 [8.00]
*-06	SEAF-XX-01-RA-06-XX	SUB-IM-C-242-01-06-X-X	WT-28-02-T	0.415 [10.54]
*-08	SEAF-XX-01-RA-08-XX	SUB-IM-C-242-01-08-X-X	WT-28-02-T	0.415 [10.54]
*-10	SEAF-XX-01-RA-10-XX	SUB-IM-C-242-01-10-X-X	WT-28-02-T	0.415 [10.54]

(* = SEE NOTE 8)

TABLE 1

No. OF POS. PER ROW	"A"	"B"	"D"	"E"	"F"	"N"
-20	0.950 [24.13]	1.130 [28.70]	1.290 [32.77]	1.210 [30.73]	1.270 [32.26]	1.090 [27.69]
-30	1.450 [36.83]	1.630 [41.40]	1.790 [45.47]	1.710 [43.43]	1.770 [44.96]	1.590 [40.39]
-40	1.950 [49.53]	2.130 [54.10]	2.290 [58.17]	2.210 [56.13]	2.270 [57.66]	2.090 [53.09]
-50	2.450 [62.23]	2.630 [66.80]	2.790 [70.87]	2.710 [68.83]	2.770 [70.36]	2.590 [65.79]

TABLE 4

No. OF ROWS	"M"				"BACK STRAP"
	20 POS	30 POS	40 POS	50 POS	
-04	1.182 [30.02]	1.682 [42.72]	2.182 [55.42]	2.682 [68.12]	N/A
*-06, *-08 & *-10	N/A	N/A	N/A	N/A	SEAX-RA-BS-XX-01

(* = SEE NOTE 8)

- NOTES:
- ⊕ REPRESENTS A CRITICAL DIMENSION.
 - MINIMUM PUSH-OUT FORCE: .50 LBS[2.2N].
 - INSPECT DIMENSION AT 4 CORNERS OF PART.
 - ONLY FULL REEL QUANTITIES ARE SHIPPED ON A REEL WITH LEADER AND TRAILER.
 - NOTE DELETED
 - NOTE DELETED
 - ATTACH LABEL "SEAX-0001" TO EACH TAPE & REEL PACKAGE.
 - ON -06, -08 & -10 ROW ASSEMBLIES, SEE FIG 10, SHEET 5 FOR CAT FIXTURE VIEW.
 - CHECK DIMENSION ON FIRST AND LAST ROW OF TAILS.
 - A 20-30°C TEMPERATURE DIFFERENCE MAY EXIST BETWEEN THIS HIGH-DENSITY COMPONENT AND THE BOARD SURFACE DURING REFLOW. SAMTEC RECOMMENDS A THERMAL STUDY BE PERFORMED TO UNDERSTAND THE TEMPERATURE GRADIENTS YOU MAY EXPERIENCE.**
 - SOME RELAXATION/WARPING OF THE BACK STRAP IS ACCEPTABLE AFTER PROCESSING.
 - SEE SHEET 5 FOR PROCESSING INFORMATION.
 - VOID PATTERN MAY VARY BY ROW AND END OPTION.

FIG 1 (SEAF-20-0T-X-04-X-RA-GP) (SOME DETAIL OMITTED FOR CLARITY)

UNLESS OTHERWISE SPECIFIED, DIMENSIONS ARE IN INCHES.

TOLERANCES ARE:

DECIMALS ANGLES

.XX: ±.01 [.3] 2°

.XXX: ±.005 [.13]

.XXXX: ±.0020 [.051]

PROPRIETARY NOTE

THIS DOCUMENT CONTAINS INFORMATION CONFIDENTIAL AND PROPRIETARY TO SAMTEC, INC. AND SHALL NOT BE REPRODUCED OR TRANSFERRED TO OTHER DOCUMENTS OR DISCLOSED TO OTHERS OR USED FOR ANY PURPOSE OTHER THAN THAT WHICH IT WAS OBTAINED WITHOUT THE EXPRESSED WRITTEN CONSENT OF SAMTEC, INC.



520 PARK EAST BLVD. NEW ALBANY, IN 47150
PHONE: 812-944-6733 FAX: 812-948-5047
e-Mail: info@SAMTEC.COM code 55322

MATERIAL: DO NOT SCALE DRAWING SHEET SCALE: 2:1
INSULATOR: LCP COLOR: BLACK
CONTACT: PHOS BRONZE .006 THICK

DESCRIPTION: SEAF-RA ASSEMBLY
DWG. NO. SEAF-XX-XX-X-XX-X-RA-XX-TR

BY: C. PIERCE 12/15/2007 SHEET 1 OF 5

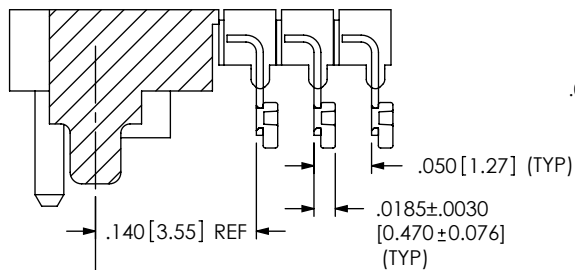

SECTION "E"-"E"
 SCALE 6:1

SUB-IM-C-242-XX-X-X
 (SEE TABLE 2, SHEET 1)

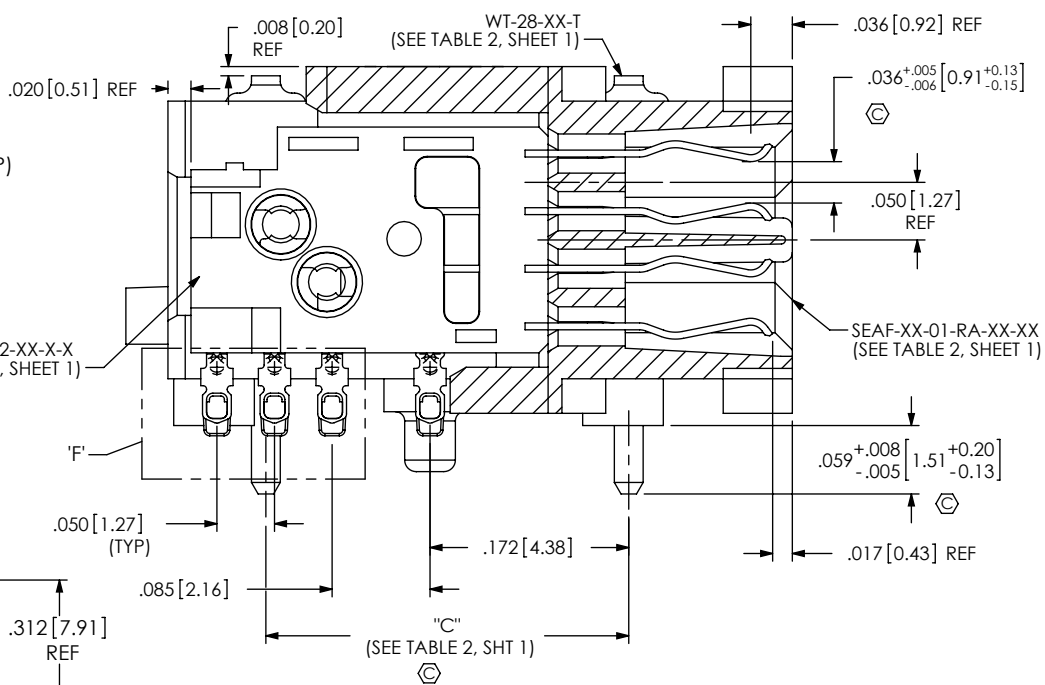

SECTION "A"-"A"
 SCALE 6:1

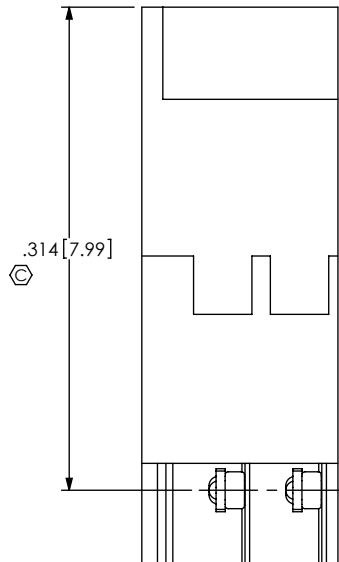

DETAIL 'J'
 SCALE 8:1

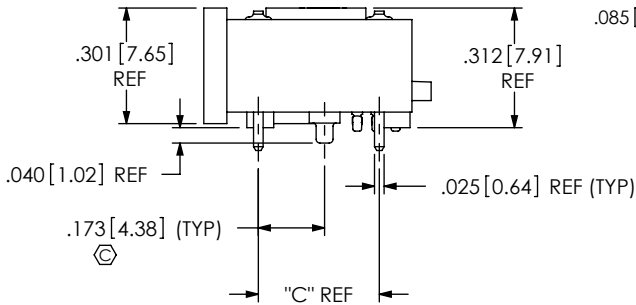

VIEW "G"-"G"

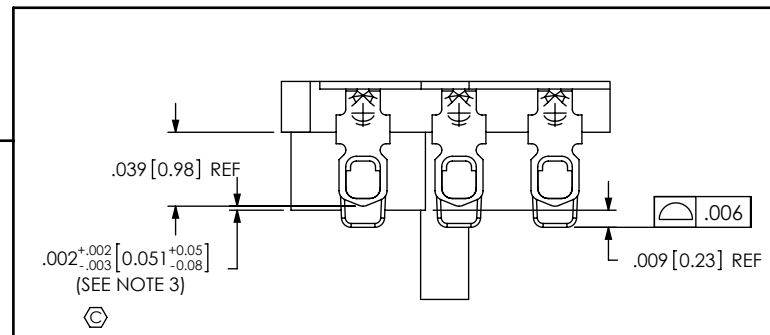

DETAIL 'F'
 SCALE 10:1

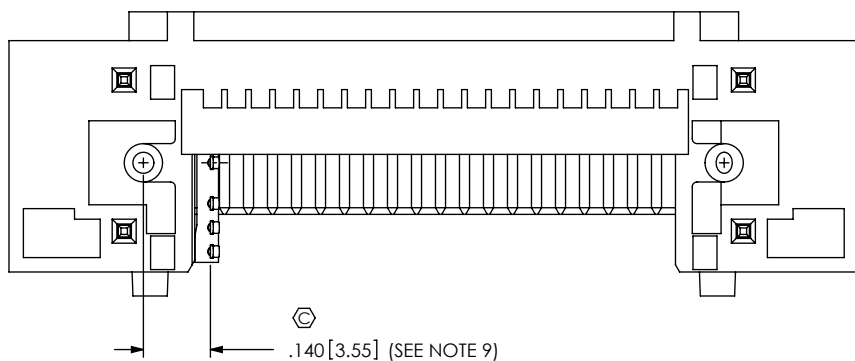

IN-PROCESS VIEW
 (SEAF-20-01-X-04-X-RA-GP SHOWN)
 (FILL FIRST WAFER TO DIMENSIONS SHOWN)

PROPRIETARY NOTE

THIS DOCUMENT CONTAINS INFORMATION CONFIDENTIAL AND PROPRIETARY TO SAMTEC, INC. AND SHALL NOT BE REPRODUCED OR TRANSFERRED TO OTHER DOCUMENTS OR DISCLOSED TO OTHERS OR USED FOR ANY PURPOSE OTHER THAN THAT WHICH IT WAS OBTAINED WITHOUT THE EXPRESSED WRITTEN CONSENT OF SAMTEC, INC.

DO NOT SCALE DRAWING

SHEET SCALE: 2:1



520 PARK EAST BLVD, NEW ALBANY, IN 47150
 PHONE: 812-944-6733 FAX: 812-948-5047
 e-Mail: info@SAMTEC.com code 55322

DESCRIPTION:

SEAF-RA ASSEMBLY

DWG. NO.

SEAF-XX-XX-X-XX-X-RA-XX-TR

BY: C. PIERCE 12/15/2007 SHEET 2 OF 5

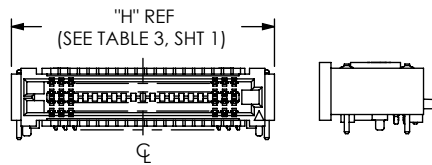
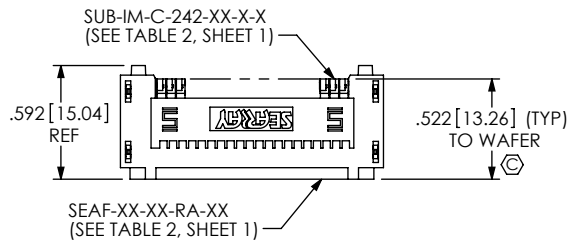

FIG 2
(SEAF-20-01-X-04-X-RA SHOWN)
(SAME AS FIG 1 EXCEPT AS NOTED)
(SOME DETAIL REMOVED FOR CLARITY)

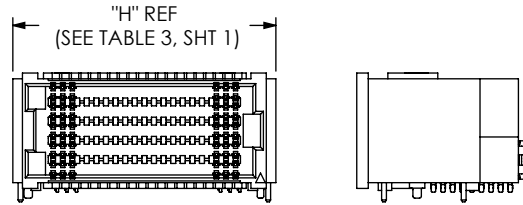
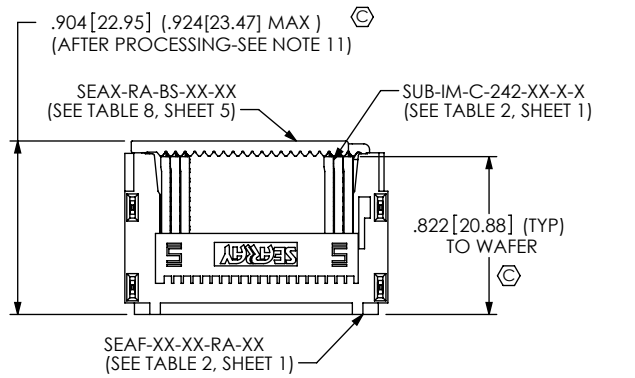

FIG 9
(SEAF-20-01-X-T0-X-RA SHOWN)
(SAME AS FIG 4 EXCEPT AS NOTED)
(SOME DETAIL REMOVED FOR CLARITY)

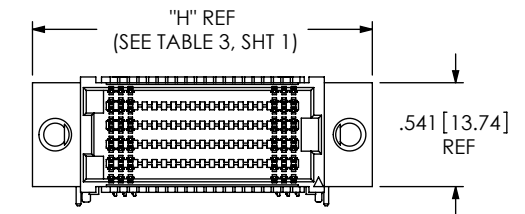
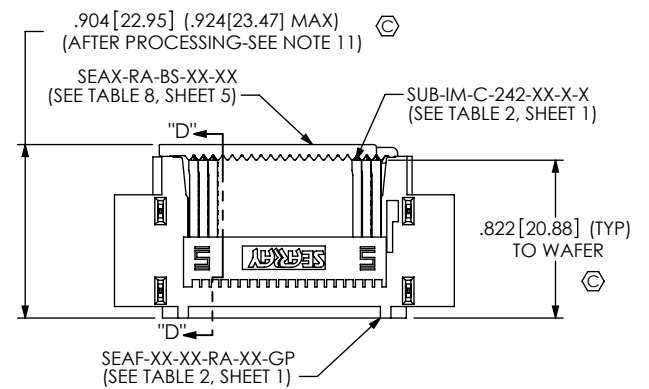

FIG 9
(SEAF-20-01-X-T0-X-RA-GP SHOWN)
(SAME AS FIG 4 EXCEPT AS NOTED)
(SOME DETAIL REMOVED FOR CLARITY)

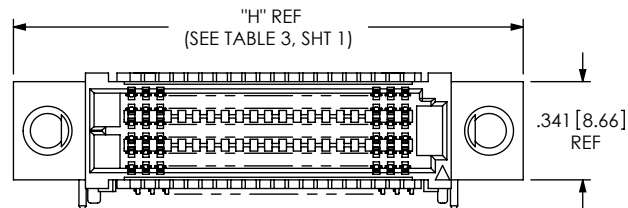
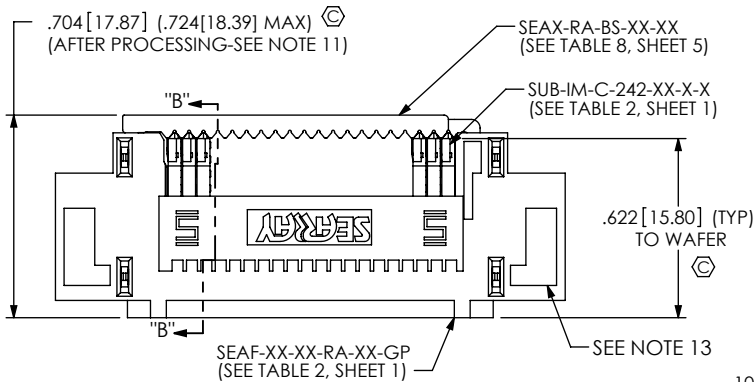
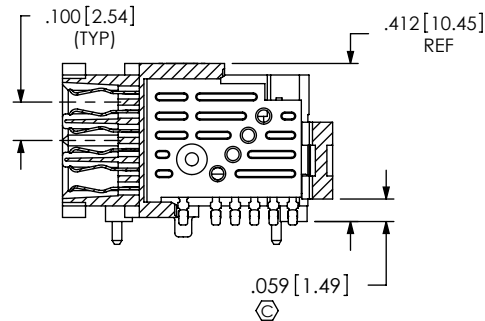

FIG 3
(SEAF-20-01-X-06-X-RA-GP)
(SAME AS FIG 1 EXCEPT AS NOTED)
(SOME DETAIL REMOVED FOR CLARITY)



SECTION "B"-"B"
SCALE 2 : 1

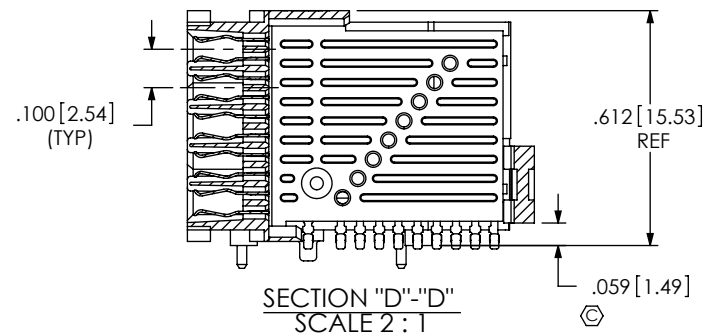

FIG 4
(SEAF-20-01-X-T0-X-RA-GP)
(SAME AS FIG 1 EXCEPT AS NOTED)
(SOME DETAIL REMOVED FOR CLARITY)

PROPRIETARY NOTE

THIS DOCUMENT CONTAINS INFORMATION CONFIDENTIAL AND PROPRIETARY TO SAMTEC, INC. AND SHALL NOT BE REPRODUCED OR TRANSFERRED TO OTHER DOCUMENTS OR DISCLOSED TO OTHERS OR USED FOR ANY PURPOSE OTHER THAN THAT WHICH IT WAS OBTAINED WITHOUT THE EXPRESSED WRITTEN CONSENT OF SAMTEC, INC.

DO NOT SCALE DRAWING

SHEET SCALE: 1:1



520 PARK EAST BLVD, NEW ALBANY, IN 47150
PHONE: 812-944-6733 FAX: 812-948-5047
e-Mail: info@SAMTEC.com code 55322

DESCRIPTION:
SEAF-RA ASSEMBLY

DWG. NO.
SEAF-XX-XX-X-XX-X-RA-XX-TR

BY: C. PIERCE 12/15/2007 SHEET 3 OF 5

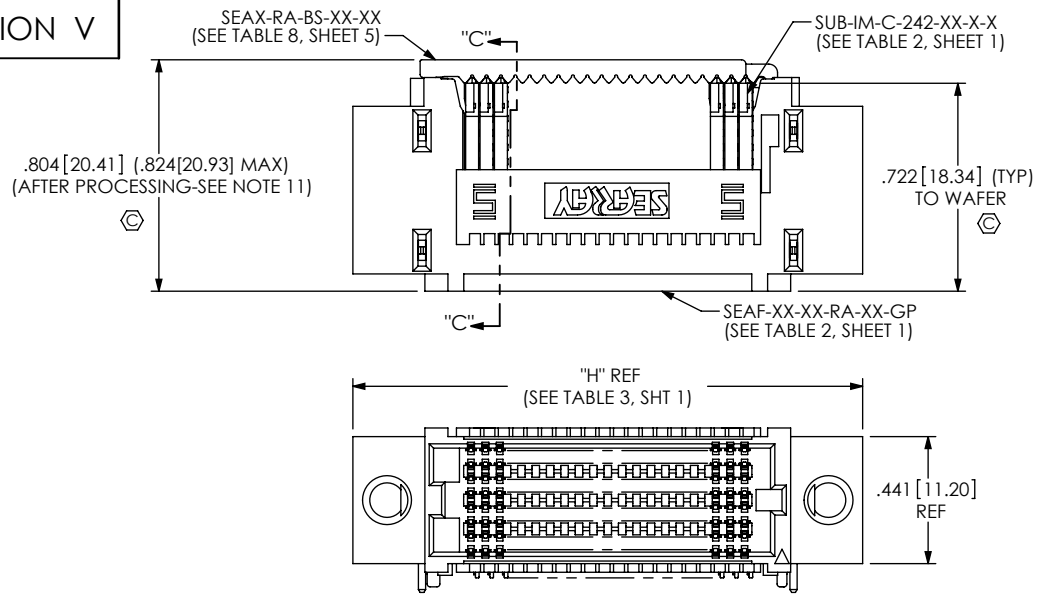

FIG 5
(SEAF-20-0T-X-08-X-RA-GP)
(SAME AS FIG 1 EXCEPT AS NOTED)
(SOME DETAIL REMOVED FOR CLARITY)

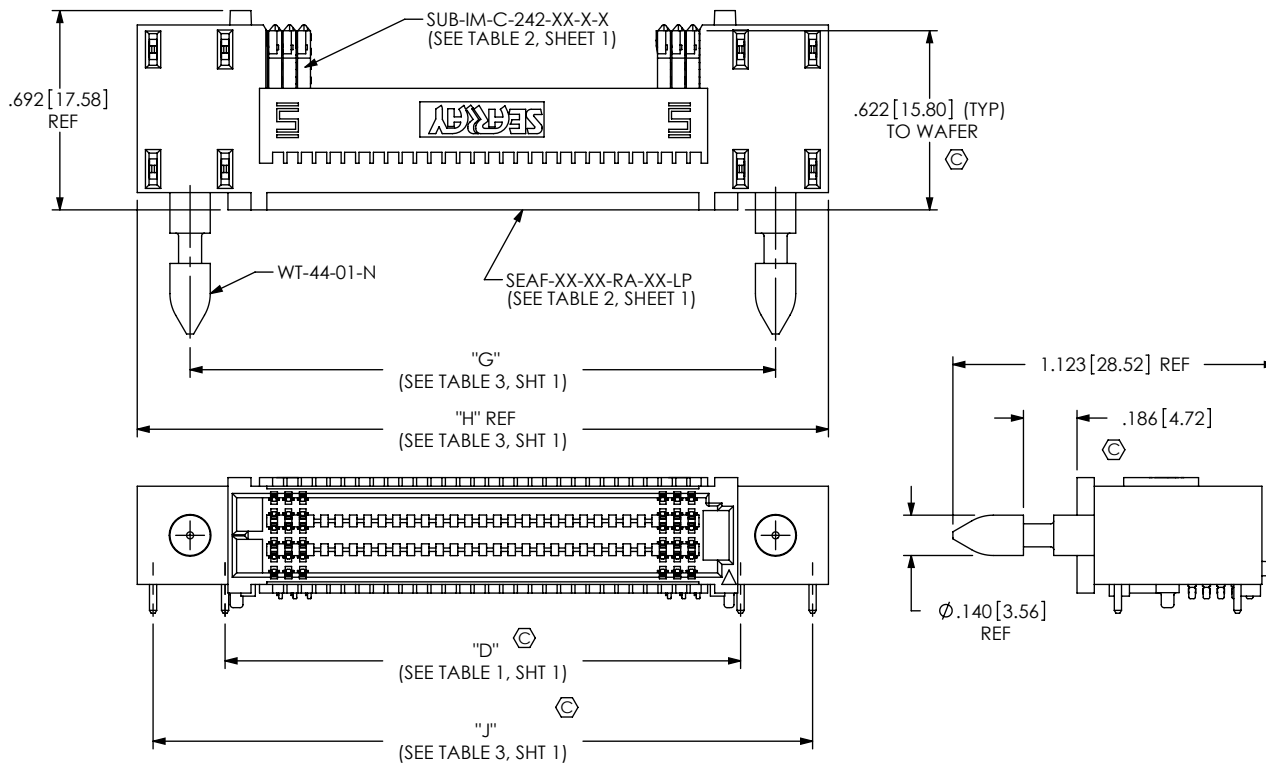
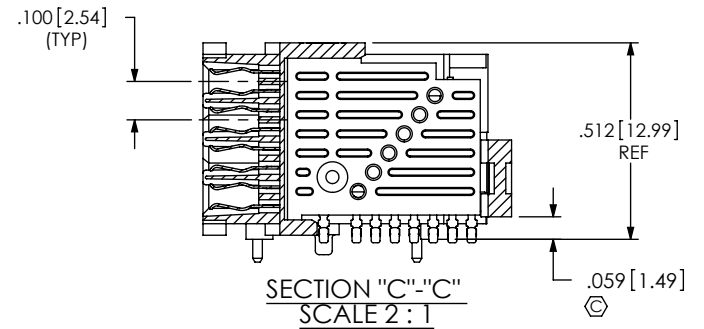

FIG 6
(SEAF-30-0T-X-06-X-RA-LP)
(SOME DETAIL OMITTED FOR CLARITY)
(SAME AS FIG 3 EXCEPT AS SHOWN)

PROPRIETARY NOTE
THIS DOCUMENT CONTAINS INFORMATION
CONFIDENTIAL AND PROPRIETARY TO
SAMTEC, INC. AND SHALL NOT BE REPRODUCED
OR TRANSFERRED TO OTHER DOCUMENTS OR
DISCLOSED TO OTHERS OR USED FOR ANY
PURPOSE OTHER THAN THAT WHICH IT WAS
OBTAINED WITHOUT THE EXPRESSED WRITTEN
CONSENT OF SAMTEC, INC.

DO NOT SCALE DRAWING

SHEET SCALE: 1:1

samtec

520 PARK EAST BLVD, NEW ALBANY, IN 47150
PHONE: 812-944-6733 FAX: 812-948-5047
e-Mail info@SAMTEC.com code 55322

DESCRIPTION:
SEAF-RA ASSEMBLY

DWG. NO.
SEAF-XX-XX-X-XX-X-RA-XX-TR

BY: C. PIERCE 12/15/2007 SHEET 4 OF 5

ROWS	"L"		"P" ϕ		"K" NO -GP OPTION				"K" WITH -GP OPTION				"K" WITH -LP OPTION				"Q"
					20 POS	30 POS	40 POS	50 POS	20 POS	30 POS	40 POS	50 POS	20 POS	30 POS	40 POS	50 POS	
-04	276	[7.01]	.295	[7.49]	.538 [13.65]	.788 [20.00]	1.038 [26.35]	1.288 [32.70]	.738 [18.73]	.988 [25.08]	1.238 [31.43]	1.488 [37.78]	N/A	N/A	N/A	N/A	.124 [3.15]
-06	376	[9.55]	.295	[7.49]	.538 [13.65]	.788 [20.00]	1.040 [26.40]	1.288 [32.70]	.738 [18.73]	.988 [25.08]	1.238 [31.43]	1.488 [37.78]	.803 [20.38]	1.053 [26.73]	1.303 [33.08]	1.553 [39.43]	.124 [3.15]
-08	483	[12.27]	.649	[16.48]	.361 [9.16]	.611 [15.51]	.861 [21.86]	1.111 [28.21]	.561 [14.24]	.811 [20.59]	1.061 [26.94]	1.311 [33.29]	N/A	N/A	N/A	N/A	.030 [0.76]
-10	583	[14.81]	.649	[16.48]	.361 [9.16]	.611 [15.51]	.861 [21.86]	1.111 [28.21]	.561 [14.24]	.811 [20.59]	1.061 [26.94]	1.311 [33.29]	N/A	N/A	N/A	N/A	.030 [0.76]

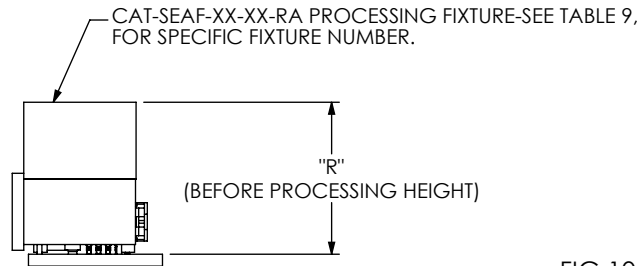
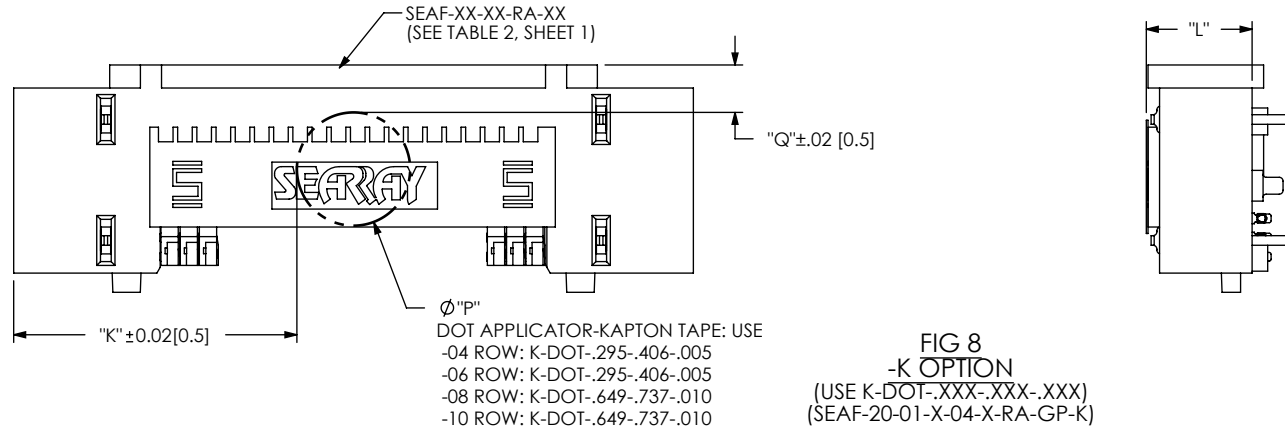

FIG 10
 SEAF-RA PROCESSING FIXTURE
 (USE CAT-SEAF-XX-XX-RA FIXTURE)

TABLE 7	
ROW	"R"
-04	N/A
**_06	.792 [20.12]
-08	.892 [22.66]
-10	.992 [25.20]

(** = NOT ENGINEERING APPVD)

NOTE:
 FIG 8, DIMENSION "R" INDICATES CONNECTOR/FIXTURE HEIGHT ON PCB. TO GUARANTEE ENOUGH REFLOW OVEN WORKING SPACE, DIMENSION "R", PCB THICKNESS, AND THE HEIGHT OF THE COMPONENTS ON THE OPPOSITE SIDE OF THE BOARD NEED TO BE CONSIDERED.

TABLE 9		
SEARAY™ FIXTURE TOOLS		
PART NUMBER	POSITIONS	ROW
CAT-SEAF-20-01-RA	20	-08 AND -10
CAT-SEAF-30-01-RA	30	-08 AND -10
CAT-SEAF-40-01-RA	40	-08 AND -10
CAT-SEAF-50-01-RA	50	-08 AND -10

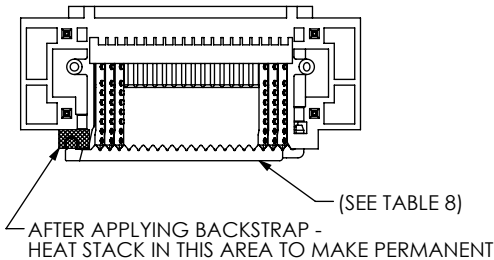

FIG 11
 HEAT STAKING BACKSTRAP

TABLE 8	
No. OF POSITIONS	"BACKSTRAP"
-20	SEAX-RA-BS-20-01
-30	SEAX-RA-BS-30-01
-40	SEAX-RA-BS-40-01
-50	SEAX-RA-BS-50-01

PROPRIETARY NOTE
 THIS DOCUMENT CONTAINS INFORMATION CONFIDENTIAL AND PROPRIETARY TO SAMTEC, INC. AND SHALL NOT BE REPRODUCED OR TRANSFERRED TO OTHER DOCUMENTS OR DISCLOSED TO OTHERS OR USED FOR ANY PURPOSE OTHER THAN THAT WHICH IT WAS OBTAINED WITHOUT THE EXPRESSED WRITTEN CONSENT OF SAMTEC, INC.

samtec
 520 PARK EAST BLVD, NEW ALBANY, IN 47150
 PHONE: 812-944-6733 FAX: 812-948-5047
 e-Mail: info@SAMTEC.com code 55322

DO NOT SCALE DRAWING
 SHEET SCALE: 2:1

DESCRIPTION:
 SEAF-RA ASSEMBLY

DWG. NO.
SEAF-XX-XX-X-XX-X-RA-XX-TR

BY: C. PIERCE 12/15/2007 SHEET 5 OF 5