

DO NOT
SCALE FROM
THIS PRINT

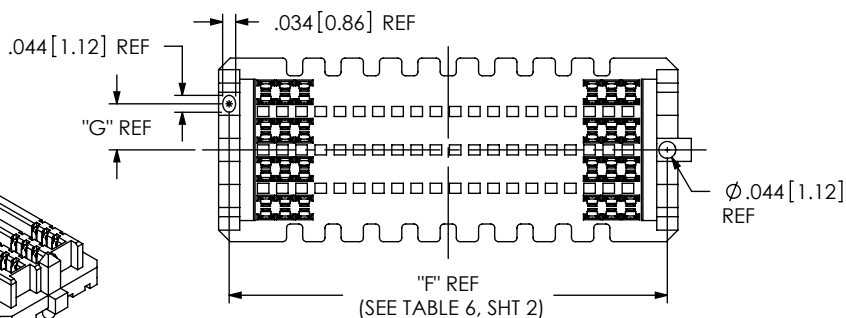
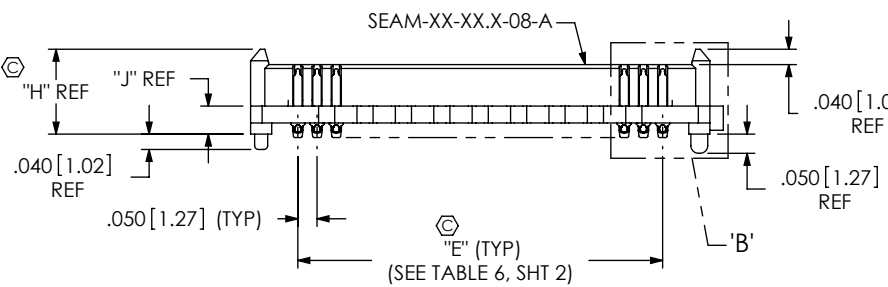
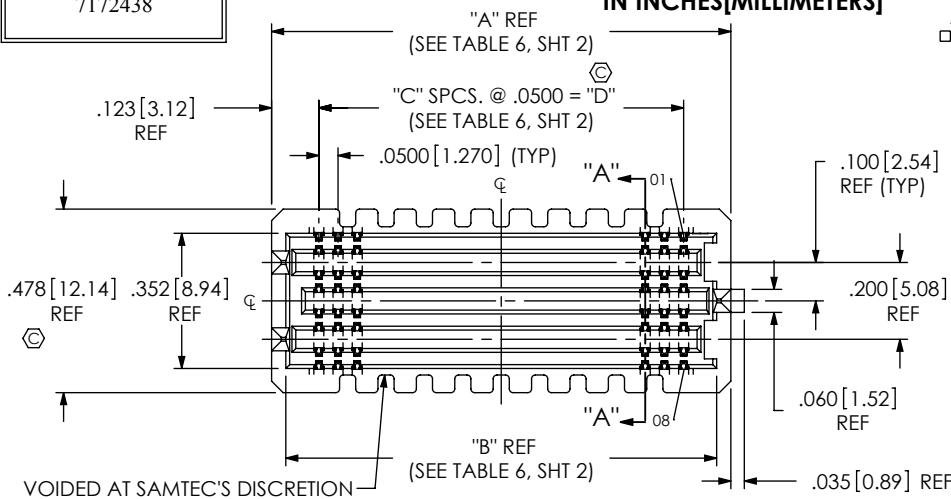

FIG 1
-08: 8 ROW
(SEAM-30-02.0-XX-08-1-A-XX-K-TR SHOWN)
(SOME CENTER FEATURES REMOVED FOR CLARITY)

No. OF POSITIONS
□ -10, ☒ -15, ** -19 -20,
△ -25, -30, -40, -50
(PER ROW)

LEAD STYLE
-02.0 (SEE TABLE 1)
-03.0 (SEE TABLE 1)
-03.5 (SEE TABLE 1)
***-05.5 (SEE TABLE 1)
****-06.5 (SEE TABLE 8, SHT 3)
(SEE NOTE 14)
-07.0 (SEE TABLE 8, SHT 3)
-09.0 (SEE TABLE 8, SHT 3)
-11.0 (SEE TABLE 8, SHT 3)
*-13.0 (SEE TABLE 8, SHT 3)

PLATING SPECIFICATION
-L: 10µ" LIGHT GOLD IN CONTACT AREA, MATTE TIN ON TAIL
-(LEAD STYLE -02.0 THRU-05.5: USE NEW-SUB-T-1M36-XX-X-L-X)
-(LEAD STYLE -06.5 THRU-13.0: USE NEW-SUB-T-1M38-XX-X-L-X)
-SM: 30µ" SELECTIVE GOLD IN CONTACT AREA, MATTE TIN ON TAIL
-(LEAD STYLE -02.0 THRU-05.5: USE NEW-SUB-T-1M36-XX-X-S-X)
-(LEAD STYLE -06.5 THRU-13.0: USE NEW-SUB-T-1M38-XX-X-S-X)
-S: 30µ" SELECTIVE GOLD IN CONTACT AREA, MATTE TIN ON TAIL
-(LEAD STYLE -02.0 THRU-05.5: USE NEW-SUB-T-1M36-XX-X-S-X)
-(LEAD STYLE -06.5 THRU-13.0: USE NEW-SUB-T-1M38-XX-X-S-X)

ROW
-04: 4 ROWS (SEE FIG 3, SHT 4)
(NOT AVAILABLE IN -13.0 LEAD STYLE)
-05: 5 ROWS (SEE FIG 7, SHT 5) (SEE NOTE 14)
-06: 6 ROWS (SEE FIG 6, SHT 5)
-08: 8 ROWS (SEE FIG 1)
-10: 10 ROWS (SEE FIG 4, SHT 4)

No. OF ROWS	"G"
-04	.079 [2.01]
-05, -06	.120 [3.05]
-08	.120 [3.05]
-10	.120 [3.05]

TAPE & REEL (SEE NOTES 8, 9 & 10)

K DOT (SEE FIG 5, SHT 4) (SEE NOTE 7)
DOT APPLICATOR-KAPTON TAPE.
-04 ROW: USE K-DOT-.236-.343-.005
-05/-06 ROW: USE K-DOT-.236-.343-.005
-08 ROW: USE K-DOT-.325-.450-.005
-10 ROW: USE K-DOT-.404-.500-.005

OPTION
-GP: GUIDE POST (SEE FIG. 9, SHT 6)
(ONLY AVAILABLE WITH -02.0 LEAD STYLE, 20, 30, 40, & 50 POSITION)
-EP: EXTENDED GUIDE POST (SEE FIG. 10, SHT 6)
(ONLY AVAILABLE WITH -02.0& -03.5 LEAD STYLE, 20, 30, 40, & 50 POSITION)

ALIGNMENT PIN (SEE NOTE 6 & T2)

SOLDER COMPOSITION & STYLE
-1: 63% TIN / 37% LEAD
CHARGE TAIL
(USE NEW-T-1M3X-XX-X-1)
-2: 95.5% TIN / 3.8% SILVER / .7% COPPER
CHARGE TAIL
(USE NEW-T-1M3X-XX-X-2)

* = NOT TOOLED
□ = 10 POSITION ONLY AVAILABLE IN 4 ROW
☒ = ONLY AVAILABLE IN A 10 ROW
△ = ONLY AVAILABLE WITH -02.0 OR -03.5 LEAD STYLE & 4 ROW
** = ONLY AVAILABLE IN 6 ROW WITH -03.5 OR -05.5 LEAD STYLE
*** = ONLY AVAILABLE WITH 19 POSITION, 6 ROWS
**** = ONLY AVAILABLE IN 8 & 10 ROW

STYLE	"H"	"J"	BODY CALLOUT	TERMINAL
				SOLDER CHARGE TAIL
-02.0	.221 [5.61]	.073 [1.85]	SEAM-XX-02.0-XX-X	NEW-SUB-T-1M36-02.0-X-X
-03.0	.260 [6.60]	.112 [2.84]	SEAM-XX-03.0-XX-X	NEW-SUB-T-1M36-03.0-X-X
-03.5	.280 [7.11]	.132 [3.35]	SEAM-XX-03.5-XX-X	NEW-SUB-T-1M36-03.5-X-X
-05.5	.359 [9.12]	.211 [5.35]	SEAM-XX-05.5-XX-X	NEW-SUB-T-1M36-05.5-X-X

(SEE SHEET 3 FOR LEAD STYLES -06.5 THRU -13.0)

- NOTES:
1. Ⓞ REPRESENTS A CRITICAL DIMENSION.
2. MINIMUM PUSHOUT FORCE: 0.50 LBS.
3. NOTE DELETED.
4. 5 ROW SOLDER TAILS ARE NOT SYMMETRICAL WITH BODY WIDTH (.378[9.60] SEE FIG. 7, SHEET 5).
5. WHEN APPLICABLE, DIMENSION C8 MUST BE MEASURED USING INSPECTION FIXTURE AT-1817-836-1 FOR 4 ROW OR AT-1817-836-2 FOR 6, 8 & 10 ROW. USE CO-AU-WI-2003-M FOR PROCESS.
6. WITHOUT -A AVAILABLE FOR EXISTING CUSTOMERS ONLY AS OF REVISION AD.
7. K DOT WILL BE SUPPLIED WHETHER OR NOT -K IS SPECIFIED.
8. TAPE & REEL WILL BE SUPPLIED WHETHER OR NOT -TR IS SPECIFIED.
9. FOR QUANTITIES UP TO 49 PIECES, NO LEADER, TRAILER, OR REEL WILL BE SUPPLIED.
10. FOR QUANTITIES 50 - 124, NO LEADER OR TRAILER WILL BE SUPPLIED.
11. ATTACH LABEL "SEAM-0001" TO EACH TAPE & REEL PACKAGE.
12. SOLDER CHARGE VOLUME IS 0.891 x 10⁻⁴ IN³ REF.
13. FOR VITA REQUIREMENTS, -A PIN SHOULD NOT BE ORDERED, 6X19 ONLY.
14. MAXIMUM ROW TO ROW VARIATION .003[0.08], MEASURED FIRST & LAST POSITIONS ONLY, ALL ROWS.
15. THESE OPTIONS AVAILABLE AS ASO (APPLICATION SPECIFIC OPTIONS) ONLY. PLEASE CONTACT SAMTEC FOR MORE INFORMATION.

UNLESS OTHERWISE SPECIFIED, DIMENSIONS ARE IN INCHES.
TOLERANCES ARE:
DECIMALS ANGLES
.XX: ±.01 [.3] 2°
.XXX: ±.005 [.13]
.XXXX: ±.0020 [.051]

PROPRIETARY NOTE
THIS DOCUMENT CONTAINS INFORMATION CONFIDENTIAL AND PROPRIETARY TO SAMTEC, INC. AND SHALL NOT BE REPRODUCED OR TRANSFERRED TO OTHER DOCUMENTS OR DISCLOSED TO OTHERS OR USED FOR ANY PURPOSE OTHER THAN THAT WHICH IT WAS OBTAINED WITHOUT THE EXPRESSED WRITTEN CONSENT OF SAMTEC, INC.



520 PARK EAST BLVD, NEW ALBANY, IN 47150
PHONE: 812-944-6733 FAX: 812-948-5047
e-Mail: info@SAMTEC.com code 55322

MATERIAL: DO NOT SCALE DRAWING SHEET SCALE: 2:1
INSULATOR: LCP, COLOR: BLACK
TERMINAL: COPPER ALLOY

DESCRIPTION:
.050 PITCH TERMINAL ARRAY ASSEMBLY
DWG. NO.

SEAM-XX-XX.X-XX-XX-X-A-XX-K-TR
BY: BRATCHER 08-09-2010 SHEET 1 OF 7

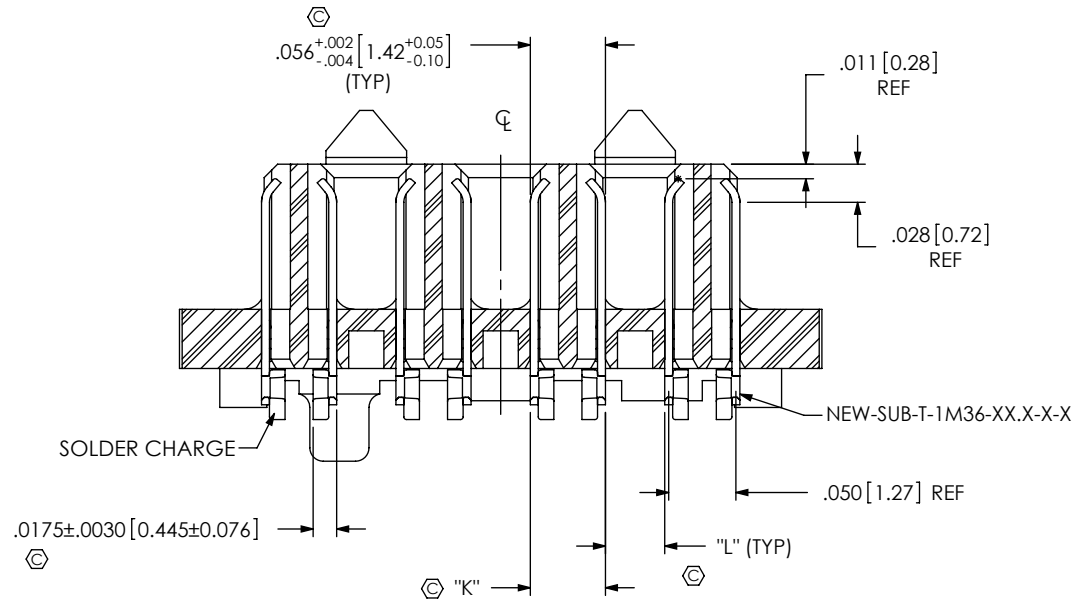
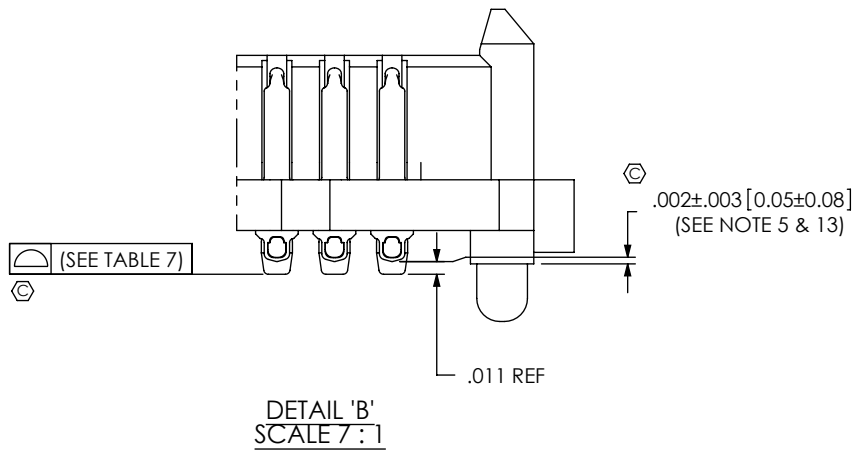

TABLE 3
STACK HEIGHT

SEAM LEAD STYLE	SEAF LEAD STYLE			
	-05.0	-06.0	-06.5	-07.5
-02.0	7mm	8mm	8.5mm	9.5mm
-03.0	8mm	9mm	9.5mm	10.5mm
-03.5	8.5mm	9.5mm	10mm	11mm
-05.5	NA	NA	12mm	NA
-06.5	11.5mm	12.5mm	13mm	14mm
-07.0	12mm	13mm	13.5mm	14.5mm
-09.0	14mm	15mm	15.5mm	16.5mm
-11.0	16mm	17mm	17.5mm	18.5mm
*-13.0	18mm	19mm	19.5mm	20.5mm

(* = NOT TOOLED)

TABLE 5

LEAD STYLE	"K"	"L"
-02.0	.0530 - .0590 [1.346] - [1.499]	.0470 - .0410 [1.194] - [1.041]
-03.0	.0530 - .0620 [1.346] - [1.575]	.0470 - .0380 [1.194] - [0.965]
-03.5	.0530 - .0645 [1.346] - [1.638]	.0470 - .0355 [1.194] - [0.902]
-05.5	.0530 - .0645 [1.346] - [1.638]	.0470 - .0355 [1.194] - [0.902]

TABLE 6

No. OF POS	"A"	"B"	"C"	"D"	"E"	"F"
□-10	.696 [17.68]	.622 [15.80]	9	.4500 [11.430]	.4500 [11.430]	.641 [16.28]
⊠-15	.946 [24.03]	.872 [22.15]	14	.7000 [17.780]	.7000 [17.780]	.891 [22.63]
** -19	1.146 [29.11]	1.072 [27.23]	18	.9000 [22.860]	.9000 [22.860]	1.091 [27.71]
-20	1.196 [30.38]	1.122 [28.50]	19	.9500 [24.130]	.9500 [24.130]	1.141 [28.98]
▴-25	1.446 [36.73]	1.372 [34.85]	24	1.2000 [30.480]	1.2000 [30.480]	1.391 [35.33]
-30	1.696 [43.08]	1.622 [41.20]	29	1.4500 [36.830]	1.4500 [36.830]	1.641 [41.68]
-40	2.196 [55.78]	2.122 [53.90]	39	1.9500 [49.530]	1.9500 [49.530]	2.141 [54.38]
-50	2.696 [68.48]	2.622 [66.60]	49	2.4500 [62.230]	2.4500 [62.230]	2.641 [67.08]

TABLE 7

LEAD STYLE	10-30 POS.	40 POS.	50 POS.
-02.0, -03.0, -03.5, -05.5, -06.5, -07.0, -09.0, *-13.0	.006 [0.152]	.009 [0.229]	.009 [0.229]
-11.0	.0085 [0.216]		

(* = NOT TOOLED)

PROPRIETARY NOTE
THIS DOCUMENT CONTAINS INFORMATION CONFIDENTIAL AND PROPRIETARY TO SAMTEC, INC. AND SHALL NOT BE REPRODUCED OR TRANSFERRED TO OTHER DOCUMENTS OR DISCLOSED TO OTHERS OR USED FOR ANY PURPOSE OTHER THAN THAT WHICH IT WAS OBTAINED WITHOUT THE EXPRESSED WRITTEN CONSENT OF SAMTEC, INC.

DO NOT SCALE DRAWING

SHEET SCALE: 2:1



520 PARK EAST BLVD. NEW ALBANY, IN 47150
PHONE: 812-944-6733 FAX: 812-948-5047
e-Mail: info@SAMTEC.com code 55322

DESCRIPTION:
.050 PITCH TERMINAL ARRAY ASSEMBLY

DWG. NO.
SEAM-XX-XX.X-XX-XX-X-A-XX-K-TR

BY: BRATCHER 08-09-2010 SHEET 2 OF 7

FIG 2
 -06.5 THRU -13.0 LEAD STYLES
 (SEAM-20-09.0-XX-08-1-A SHOWN)
 (SAME AS FIG 1, EXCEPT AS SHOWN)
 (SOME CENTER FEATURES REMOVED FOR CLARITY)

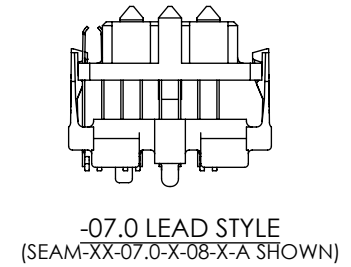
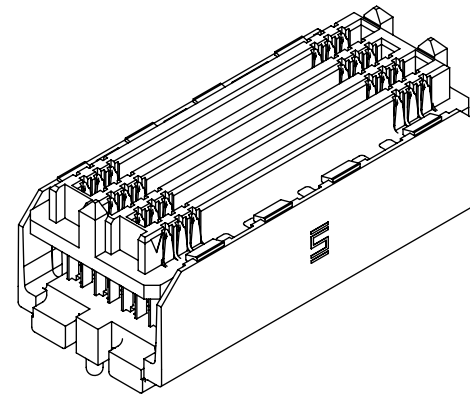
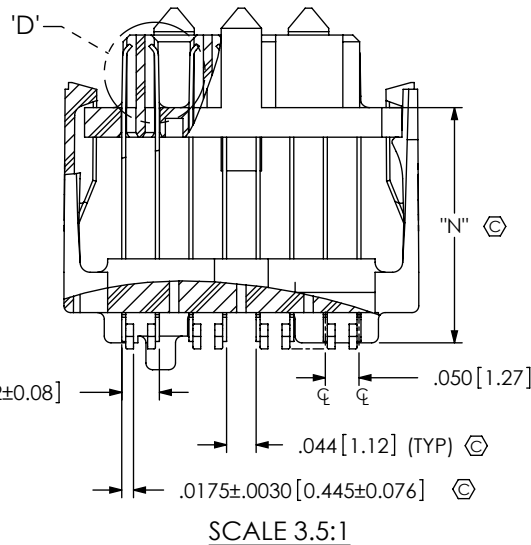
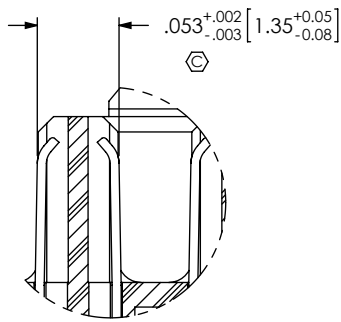
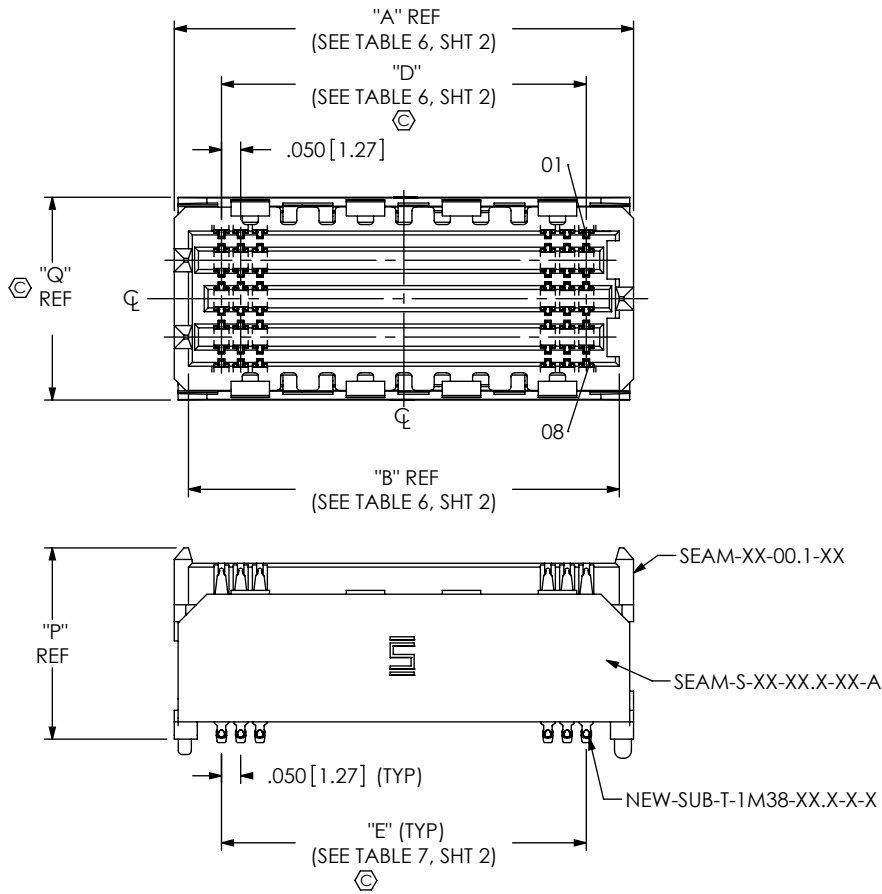

TABLE 8

ROW	STYLE	"N"	"P"	"Q"	SPACER BODY	TOP BODY	TERMINAL
-04	-07.0	.271 [6.88]	.417 [10.59]	.328 [8.33]	SEAM-S-XX-07.0-04-A	SEAM-XX-00.1-04	NEW-SUB-T-1M38-07.0-X-X
	-09.0	.350 [8.89]	.496 [12.60]	.328 [8.33]	SEAM-S-XX-09.0-04-A	SEAM-XX-00.1-04	NEW-SUB-T-1M38-09.0-X-X
	-11.0	.429 [10.90]	.575 [14.61]	.328 [8.33]	SEAM-S-XX-11.0-04-A	SEAM-XX-00.1-04	NEW-SUB-T-1M38-11.0-X-X
-05	-07.0	.271 [6.88]	.417 [10.59]	.428 [10.87]	SEAM-S-XX-07.0-06-A	SEAM-XX-00.1-06	NEW-SUB-T-1M38-07.0-X-X
	-09.0	.350 [8.89]	.496 [12.60]	.428 [10.87]	SEAM-S-XX-09.0-06-A	SEAM-XX-00.1-06	NEW-SUB-T-1M38-09.0-X-X
	-11.0	.429 [10.90]	.575 [14.61]	.428 [10.87]	SEAM-S-XX-11.0-06-A	SEAM-XX-00.1-06	NEW-SUB-T-1M38-11.0-X-X
	*-13.0	.508 [12.90]	.654 [16.61]	.428 [10.87]	SEAM-S-XX-13.0-06-A	SEAM-XX-00.1-06	NEW-SUB-T-1M38-13.0-X-X
-06	-07.0	.271 [6.88]	.417 [10.59]	.428 [10.87]	SEAM-S-XX-07.0-06-A	SEAM-XX-00.1-06	NEW-SUB-T-1M38-07.0-X-X
	-09.0	.350 [8.89]	.496 [12.60]	.428 [10.87]	SEAM-S-XX-09.0-06-A	SEAM-XX-00.1-06	NEW-SUB-T-1M38-09.0-X-X
	-11.0	.429 [10.90]	.575 [14.61]	.428 [10.87]	SEAM-S-XX-11.0-06-A	SEAM-XX-00.1-06	NEW-SUB-T-1M38-11.0-X-X
	*-13.0	.508 [12.90]	.654 [16.61]	.428 [10.87]	SEAM-S-XX-13.0-06-A	SEAM-XX-00.1-06	NEW-SUB-T-1M38-13.0-X-X
-08	-06.5	.252 [6.40]	.400 [10.16]	.528 [13.41]	SEAM-S-XX-06.5-08-A	SEAM-XX-00.1-08	NEW-SUB-T-1M38-06.5-X-X
	-07.0	.271 [6.88]	.417 [10.59]	.528 [13.41]	SEAM-S-XX-07.0-08-A	SEAM-XX-00.1-08	NEW-SUB-T-1M38-07.0-X-X
	-09.0	.350 [8.89]	.496 [12.60]	.528 [13.41]	SEAM-S-XX-09.0-08-A	SEAM-XX-00.1-08	NEW-SUB-T-1M38-09.0-X-X
	-11.0	.429 [10.90]	.575 [14.61]	.528 [13.41]	SEAM-S-XX-11.0-08-A	SEAM-XX-00.1-08	NEW-SUB-T-1M38-11.0-X-X
	*-13.0	.508 [12.90]	.654 [16.61]	.528 [13.41]	SEAM-S-XX-13.0-08-A	SEAM-XX-00.1-08	NEW-SUB-T-1M38-13.0-X-X
-10	-06.5	.252 [6.40]	.400 [10.16]	.628 [15.95]	SEAM-S-XX-06.5-10-A	SEAM-XX-00.1-10	NEW-SUB-T-1M38-06.5-X-X
	-07.0	.271 [6.88]	.417 [10.59]	.628 [15.95]	SEAM-S-XX-07.0-10-A	SEAM-XX-00.1-10	NEW-SUB-T-1M38-07.0-X-X
	-09.0	.350 [8.89]	.496 [12.60]	.628 [15.95]	SEAM-S-XX-09.0-10-A	SEAM-XX-00.1-10	NEW-SUB-T-1M38-09.0-X-X
	-11.0	.429 [10.90]	.575 [14.61]	.628 [15.95]	SEAM-S-XX-11.0-10-A	SEAM-XX-00.1-10	NEW-SUB-T-1M38-11.0-X-X
	*-13.0	.508 [12.90]	.654 [16.61]	.628 [15.95]	SEAM-S-XX-13.0-10-A	SEAM-XX-00.1-10	NEW-SUB-T-1M38-13.0-X-X

(* = NOT TOOLED)

PROPRIETARY NOTE

THIS DOCUMENT CONTAINS INFORMATION CONFIDENTIAL AND PROPRIETARY TO SAMTEC, INC. AND SHALL NOT BE REPRODUCED OR TRANSFERRED TO OTHER DOCUMENTS OR DISCLOSED TO OTHERS OR USED FOR ANY PURPOSE OTHER THAN THAT WHICH IT WAS OBTAINED WITHOUT THE EXPRESSED WRITTEN CONSENT OF SAMTEC, INC.

DO NOT SCALE DRAWING

SHEET SCALE: 2:1



520 PARK EAST BLVD, NEW ALBANY, IN 47150
 PHONE: 812-944-6733 FAX: 812-948-5047
 e-Mail: info@SAMTEC.com code 55322

DESCRIPTION:
 .050 PITCH TERMINAL ARRAY ASSEMBLY

DWG. NO.
SEAM-XX-XX.X-XX-XX-X-A-XX-K-TR

BY: BRATCHER 08-09-2010 SHEET 3 OF 7

FIG 3
 -04: 4 ROW
 (SEAM-20-02.0-XX-04-1-A SHOWN)
 (SAME AS FIG 1, EXCEPT AS SHOWN)
 (SOME CENTER FEATURES REMOVED FOR CLARITY)

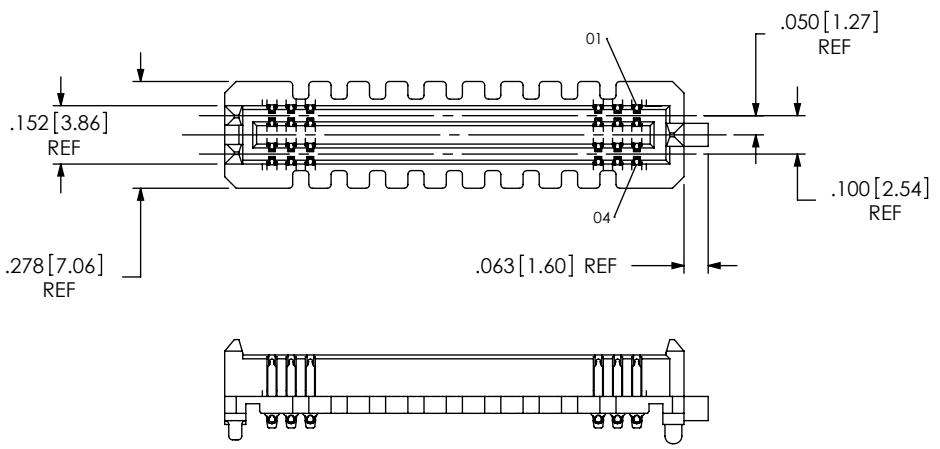

FIG 4
 -10: 10 ROW
 (SEAM-20-02.0-XX-10-1-A SHOWN)
 (SAME AS FIG 1, EXCEPT AS SHOWN)
 (SOME CENTER FEATURES REMOVED FOR CLARITY)

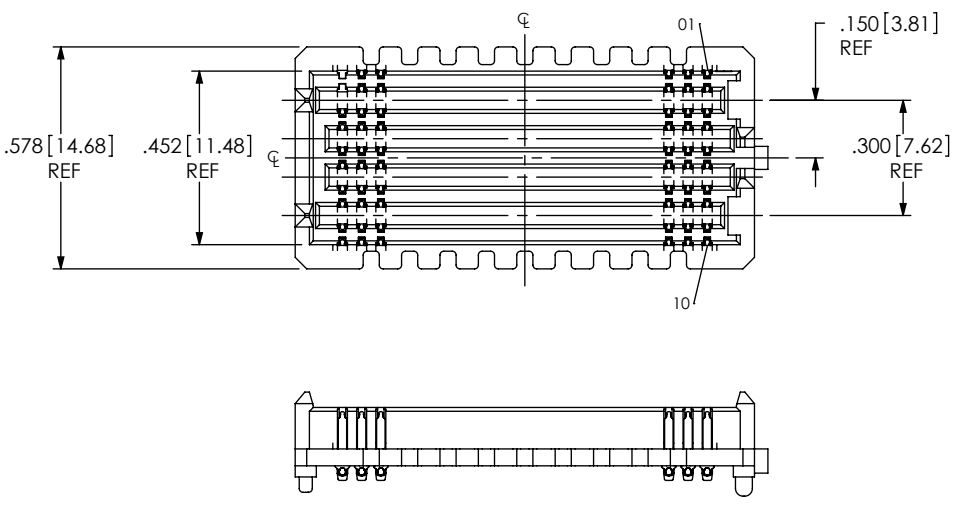

TABLE 9

ROW	Ø "R"	"S"								"T"
		□ 10 POS	⊠ 15 POS	** 19 POS	20 POS	▽ 25 POS	30 POS	40 POS	50 POS	
-04	.236 [6.00]	.230 [5.84]	.355 [9.01]	.455 [11.55]	.480 [12.19]	.605 [15.36]	.730 [18.54]	.980 [24.89]	1.230 [31.24]	.021 [0.53]
-05, -06	.236 [6.00]	.230 [5.84]	.355 [9.02]	.455 [11.56]	.480 [12.19]	.605 [15.37]	.730 [18.54]	.980 [24.89]	1.230 [31.24]	.071 [1.80]
-08	.325 [8.25]	.186 [4.71]	.222 [5.65]	.411 [10.43]	.436 [11.06]	.561 [14.24]	.686 [17.41]	.936 [23.76]	1.186 [30.11]	.076 [1.93]
-10	.404 [10.25]	.146 [3.71]	.271 [6.89]	.371 [9.43]	.396 [10.06]	.521 [13.24]	.646 [16.41]	.896 [22.76]	1.146 [29.11]	.087 [2.21]

TABLE 10

LEAD STYLE	"U"
-02.0	.186 [4.72]
-03.0	.225 [5.72]
-03.5	.245 [6.22]
-05.5	.324 [8.23]
-06.5	.365 [9.27]
-07.0	.382 [9.70]
-09.0	.461 [11.71]
-11.0	.540 [13.72]
*-13.0	.619 [15.72]

(* = NOT TOOLED)

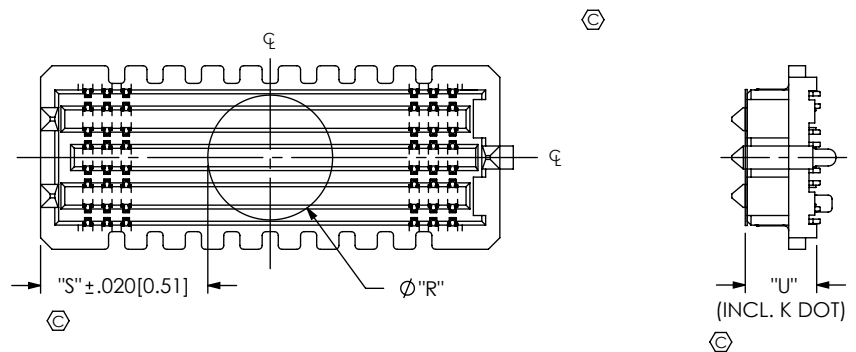

FIG 5
 -K: K DOT
 (SEAM-20-02.0-XX-08-1-A-K SHOWN)
 (SAME AS FIG 1, EXCEPT AS SHOWN)
 (SOME CENTER FEATURES REMOVED FOR CLARITY)

PROPRIETARY NOTE
 THIS DOCUMENT CONTAINS INFORMATION CONFIDENTIAL AND PROPRIETARY TO SAMTEC, INC. AND SHALL NOT BE REPRODUCED OR TRANSFERRED TO OTHER DOCUMENTS OR DISCLOSED TO OTHERS OR USED FOR ANY PURPOSE OTHER THAN THAT WHICH IT WAS OBTAINED WITHOUT THE EXPRESSED WRITTEN CONSENT OF SAMTEC, INC.

DO NOT SCALE DRAWING
 SHEET SCALE: 2:1



520 PARK EAST BLVD. NEW ALBANY, IN 47150
 PHONE: 812-944-6733 FAX: 812-948-5047
 e-Mail: info@SAMTEC.com code 55322

DESCRIPTION:
 .050 PITCH TERMINAL ARRAY ASSEMBLY

DWG. NO.
SEAM-XX-XX.X-XX-XX-X-A-XX-K-TR

BY: BRATCHER 08-09-2010 SHEET 4 OF 7

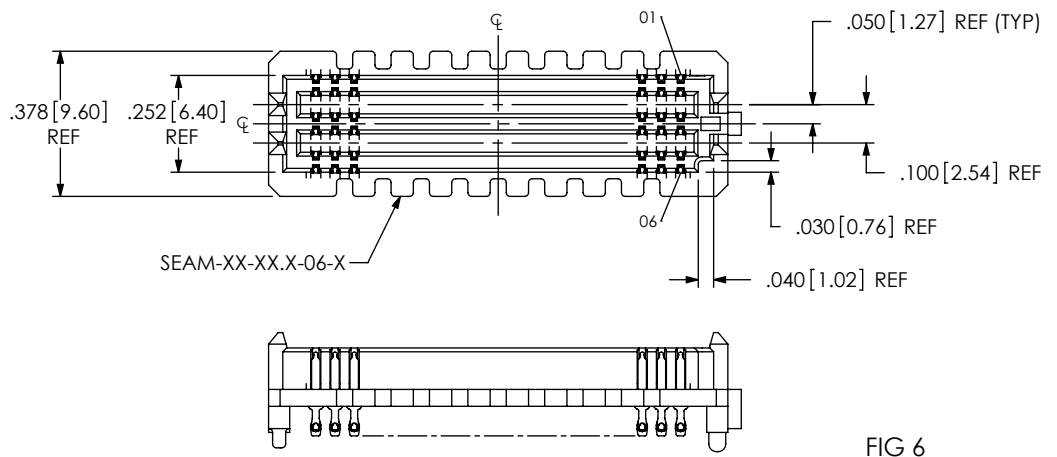
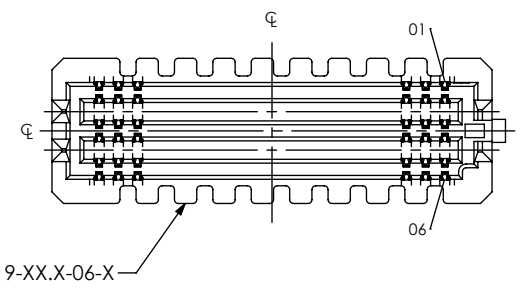
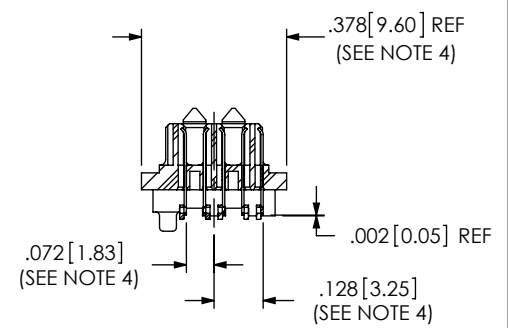
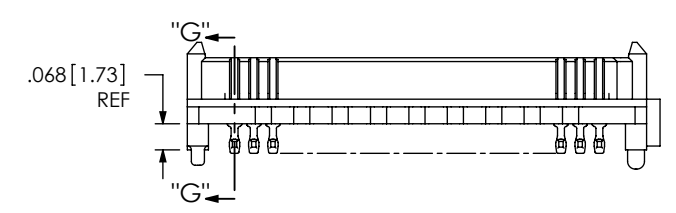
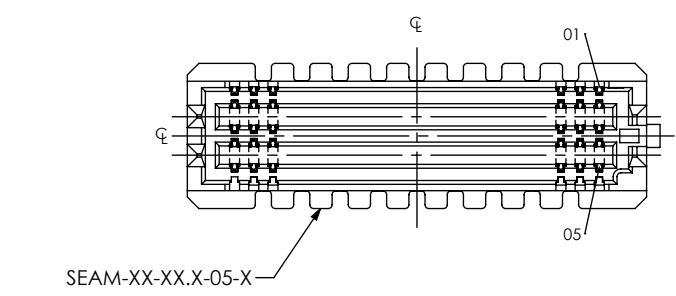

FIG 6
-06: 6 ROWS
(SEAM-20-03-0-XX-06-1-A SHOWN)
(SAME AS FIG 1, EXCEPT AS SHOWN)
(SOME CENTER FEATURES REMOVED FOR CLARITY)

FIG 8
-19: 19 POSITIONS
(SEAM-19-05.5-XX-06-1 SHOWN)
(ONLY AVAILABLE IN -06 ROW WITH -03.5 OR -05.5 LEAD STYLE)
(SAME AS FIG 6, EXCEPT AS SHOWN)
(SOME CENTER FEATURES REMOVED FOR CLARITY)
(SEE NOTE 12)



SEAM-19-XX.X-06-X



SECTION "G"-"G"

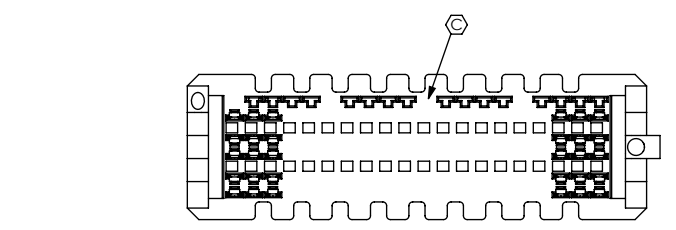
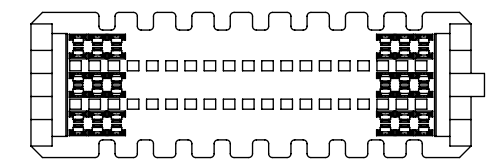
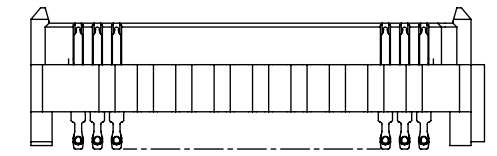
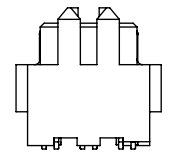

FIG 7
-05: 5 ROWS
(SEAM-20-03.5-XX-05-1-A SHOWN)
(SAME AS FIG 6, EXCEPT AS SHOWN)
(SOME CENTER FEATURES REMOVED FOR CLARITY)
(SEE NOTE 4)



PROPRIETARY NOTE
THIS DOCUMENT CONTAINS INFORMATION
CONFIDENTIAL AND PROPRIETARY TO
SAMTEC, INC. AND SHALL NOT BE REPRODUCED
OR TRANSFERRED TO OTHER DOCUMENTS OR
DISCLOSED TO OTHERS OR USED FOR ANY
PURPOSE OTHER THAN THAT WHICH IT WAS
OBTAINED WITHOUT THE EXPRESSED WRITTEN
CONSENT OF SAMTEC, INC.

DO NOT SCALE DRAWING

SHEET SCALE: 2:1



520 PARK EAST BLVD, NEW ALBANY, IN 47150
PHONE: 812-944-6733 FAX: 812-948-5047
e-Mail: info@SAMTEC.com code 55322

DESCRIPTION:
.050 PITCH TERMINAL ARRAY ASSEMBLY

DWG. NO.
SEAM-XX-XX.X-XX-XX-X-A-XX-K-TR

BY: BRATCHER 08-09-2010 SHEET 5 OF 7

FIG 9

-GP: GUIDE POST OPTION
 (ONLY AVAILABLE WITH -.02.0 LEAD STYLE, 20, 30, 40, & 50 POSITIONS)
 (MATES WITH SEAF RIGHT ANGLE ONLY)
 (SEAM-20-02.0-XX-06-1-A-GP SHOWN)
 (SAME AS FIG 1, EXCEPT AS SHOWN)
 (SOME CENTER FEATURES REMOVED FOR CLARITY)

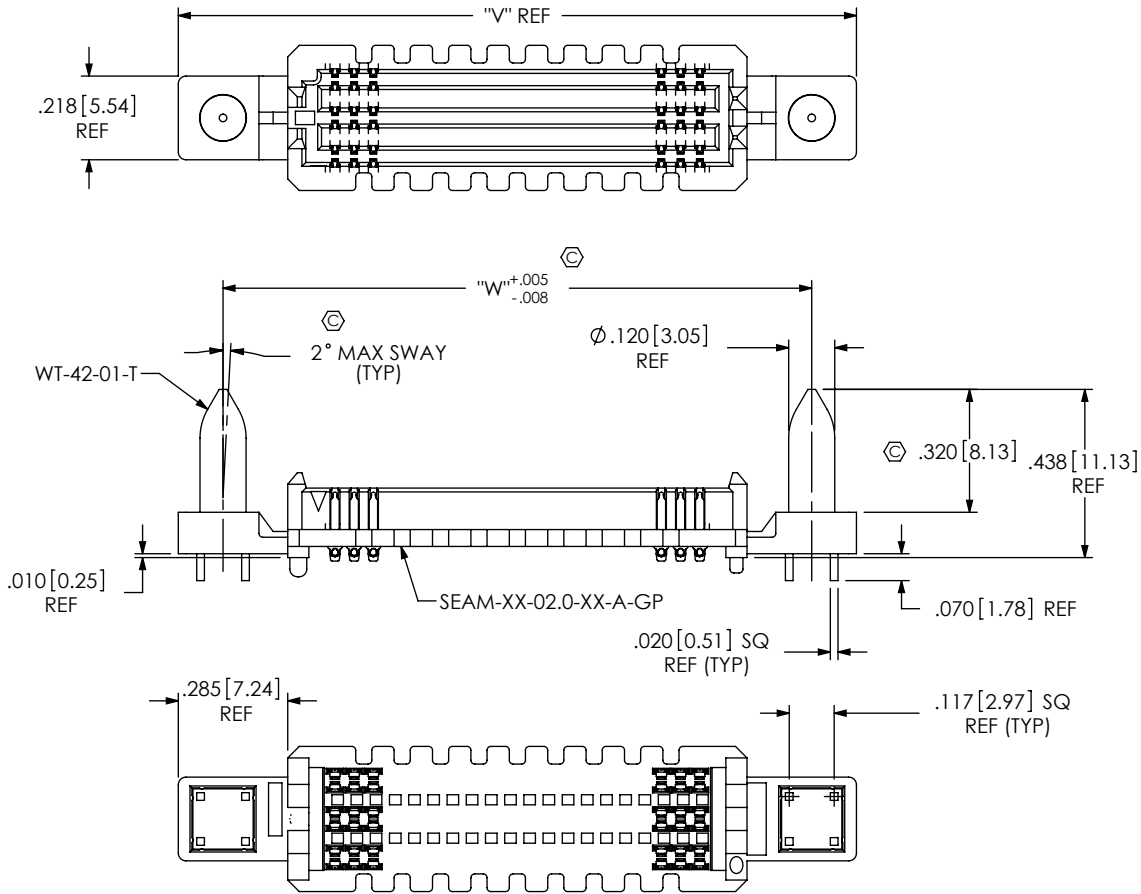

POSITIONS	"V"	"W"
-20	1.766 [44.86]	1.533 [38.94]
-30	2.266 [57.56]	2.033 [51.64]
-40	2.766 [70.26]	2.533 [64.34]
-50	3.266 [82.96]	3.033 [77.04]

FIG 10

-EP: EXTENDED GUIDE POST OPTION
 (ONLY AVAILABLE WITH -.02.0 & -.03.5 LEAD STYLES,
 20, 30, 40, & 50 POSITIONS)
 (SEAM-20-03.5-XX-06-1-A-EP SHOWN)
 (SAME AS FIG 9, EXCEPT AS SHOWN)
 (SOME CENTER FEATURES REMOVED FOR CLARITY)

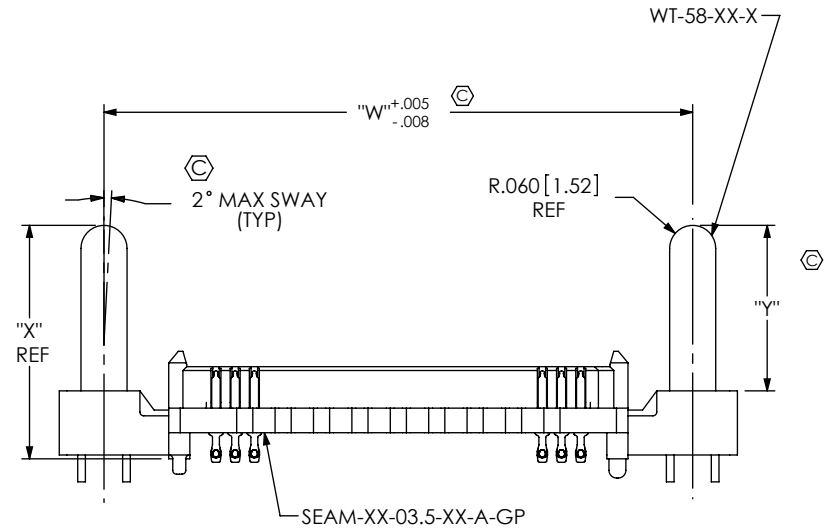

LEAD STYLE	"X"	"Y"	GUIDE POST
-.02.0	.549 [13.94]	.372 [9.45]	WT-58-01-T
-.03.5	.608 [15.44]	.431 [10.95]	WT-58-02-T

SEAM LEAD STYLE	SEAF LEAD STYLE	STACK HEIGHT
-.02.0	-.05.0	7MM
-.03.5	-.06.5	10MM

PROPRIETARY NOTE

THIS DOCUMENT CONTAINS INFORMATION CONFIDENTIAL AND PROPRIETARY TO SAMTEC, INC. AND SHALL NOT BE REPRODUCED OR TRANSFERRED TO OTHER DOCUMENTS OR DISCLOSED TO OTHERS OR USED FOR ANY PURPOSE OTHER THAN THAT WHICH IT WAS OBTAINED WITHOUT THE EXPRESSED WRITTEN CONSENT OF SAMTEC, INC.

DO NOT SCALE DRAWING

SHEET SCALE: 2:1



520 PARK EAST BLVD, NEW ALBANY, IN 47150
 PHONE: 812-944-6733 FAX: 812-948-5047
 e-Mail: info@SAMTEC.com code 55322

DESCRIPTION:
 .050 PITCH TERMINAL ARRAY ASSEMBLY

DWG. NO.
 SEAM-XX-XX.X-XX-XX-X-A-XX-K-TR

BY: BRATCHER 08-09-2010 SHEET 6 OF 7

<p>PROPRIETARY NOTE THIS DOCUMENT CONTAINS INFORMATION CONFIDENTIAL AND PROPRIETARY TO SAMTEC, INC. AND SHALL NOT BE REPRODUCED OR TRANSFERRED TO OTHER DOCUMENTS OR DISCLOSED TO OTHERS OR USED FOR ANY PURPOSE OTHER THAN THAT WHICH IT WAS OBTAINED WITHOUT THE EXPRESSED WRITTEN CONSENT OF SAMTEC, INC.</p> <p>DO NOT SCALE DRAWING</p> <p>SHEET SCALE: 2:1</p>	 <p>520 PARK EAST BLVD, NEW ALBANY, IN 47150 PHONE: 812-944-6733 FAX: 812-948-5047 e-Mail info@SAMTEC.com code 55322</p>	
	DESCRIPTION: .050 PITCH TERMINAL ARRAY ASSEMBLY	
	DWG. NO. SEAM-XX-XX.X-XX-XX-X-A-XX-K-TR	BY: BRATCHER 08-09-2010