

REV. AB

UNLESS OTHERWISE NOTED
 DIMENSIONS ARE IN INCHES TOLERANCES ARE:
 ONE PLACE DECIMALS ± .1 [3] THREE PLACE DECIMALS ± .005 [.13]
 TWO PLACE DECIMALS ± .01 [.3] FOUR PLACE DECIMALS ± .0020 [.051]
 ANGLES ± 2°

TITLE: LOW PROFILE .050 [1.27] SOCKET STRIP ASM.
 DWG NO: SLM-1XX-01-X-X
 SHEET 1 OF 1

Do not scale from this print

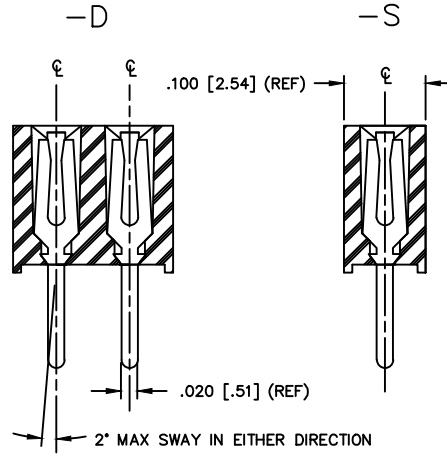
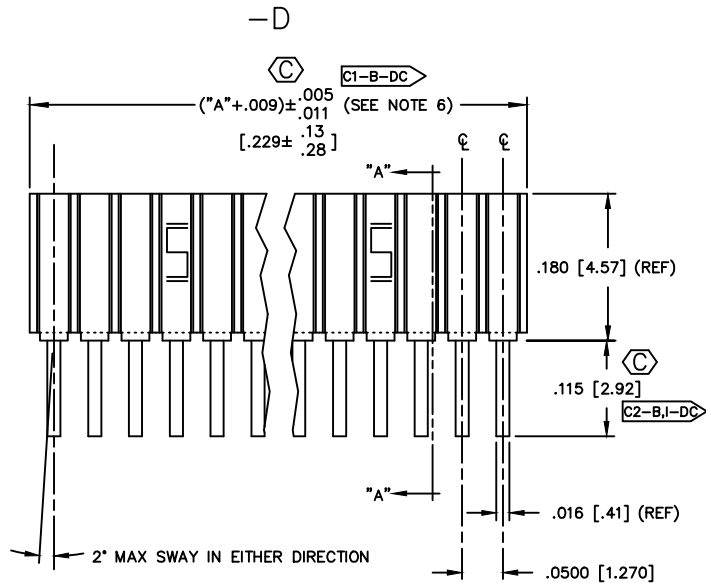
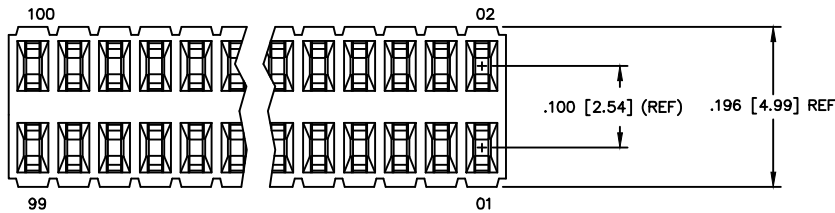
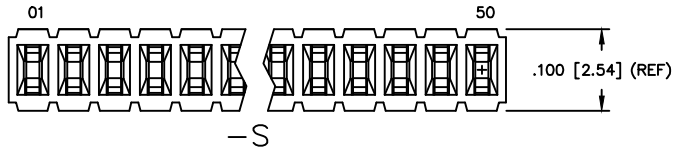

SECT. "A-A"

SLM-1XX-01-X-X
POSITION SPECIFICATION
 "A" = NO. OF POS. x .0500 [1.270]
 SINGLE: -01 THRU -50
 DOUBLE: -01 THRU -50
CONTACT STYLE
 -01: USE C-29-X

PLATING SPECIFICATION
 -G: 20μ" GOLD IN CONTACT AREA, 3μ" GOLD ON TAIL
 -T: MATTE TIN ON CONTACT AND TAIL
 -L: 10μ" LIGHT SELECTIVE GOLD IN CONTACT AREA, MATTE TIN ON TAIL
 -S: 30μ" SELECTIVE GOLD IN CONTACT AREA, MATTE TIN ON TAIL
 -F: 3μ" FLASH SELECTIVE GOLD IN CONTACT AREA, MATTE TIN ON TAIL
 -H: 30μ" HEAVY GOLD IN CONTACT AREA, 3μ" GOLD ON TAIL
 -I: 10μ" LIGHT SELECTIVE GOLD IN CONTACT AREA, MATTE TIN ON TAIL

- NOTES:
- MIN. PUSHOUT FORCE: 1 lb.
 - MAX BOW: .005 in/in [mm/mm] .0125 [.318]
 - (C) REPRESENTS CRITICAL DIMENSION FOR STATISTICAL PROCESS CONTROL.
 - TUBE ONLY -05 THRU -50 POSITIONS. -01 THRU -04 TO BE BULK PACKAGED.
 - .010" MAX CUT FLASH WITH NO FLASH ALLOW IN HOLES
 - ADDED OF .009 ONLY REQUIRED FOR CUT TO POSITION LENGTHS.
 - NOTE DELETED.

PACKAGING TABLE

ROW SPEC.	TUBES *	PLUG
-D: DOUBLE	PT-1-24-03-09	TP-09
-S: SINGLE	PT-1-24-01-12	TP-12

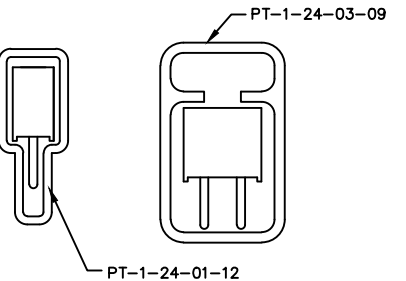

PROPRIETARY NOTE
 THIS DOCUMENT CONTAINS INFORMATION CONFIDENTIAL AND PROPRIETARY TO SAMTEC INC. AND SHALL NOT BE REPRODUCED OR TRANSMITTED IN ANY FORM OR BY ANY MEANS, ELECTRONIC OR MECHANICAL, INCLUDING PHOTOCOPYING, RECORDING, OR BY ANY INFORMATION STORAGE AND RETRIEVAL SYSTEM, WITHOUT THE EXPRESS WRITTEN CONSENT OF SAMTEC INC.

CRITICAL DIMENSION INSPECTION TABLE

ASSEMBLY OPERATION	IN-PROCESS INSPECTION
ROTARY CUT	C1
FILL	C2

MADE BY: KOLB 1-25-89
 CHECKED BY: McCARTIN
 ENG. APPROVAL: D.E.M.
 SLM-1XX-01-X-X
 SHEET 1 OF 1

samtec
 520 PARK EAST BLVD. NEW ALBANY, INDIANA 47150
 PHONE (812) 944-6733 P.O. BOX 1147
 CODE 55322