

REV. J

DIMENSIONS ARE IN INCHES		UNLESS OTHERWISE NOTED		TOLERANCES ARE:		TITLE:	DWG NO:
ONE PLACE DECIMALS: ± .1	[2.5]	THREE PLACE DECIMALS: ± .005	[.127]	ANGLES	± 2°	SSA-WIRE WRAP TAIL ASSEMBLY	SSA-1XX-W-X-XX
TWO PLACE DECIMALS: ± .01	[.25]	FOUR PLACE DECIMALS: ± .0020	[.0508]				SHEET 1 OF 1

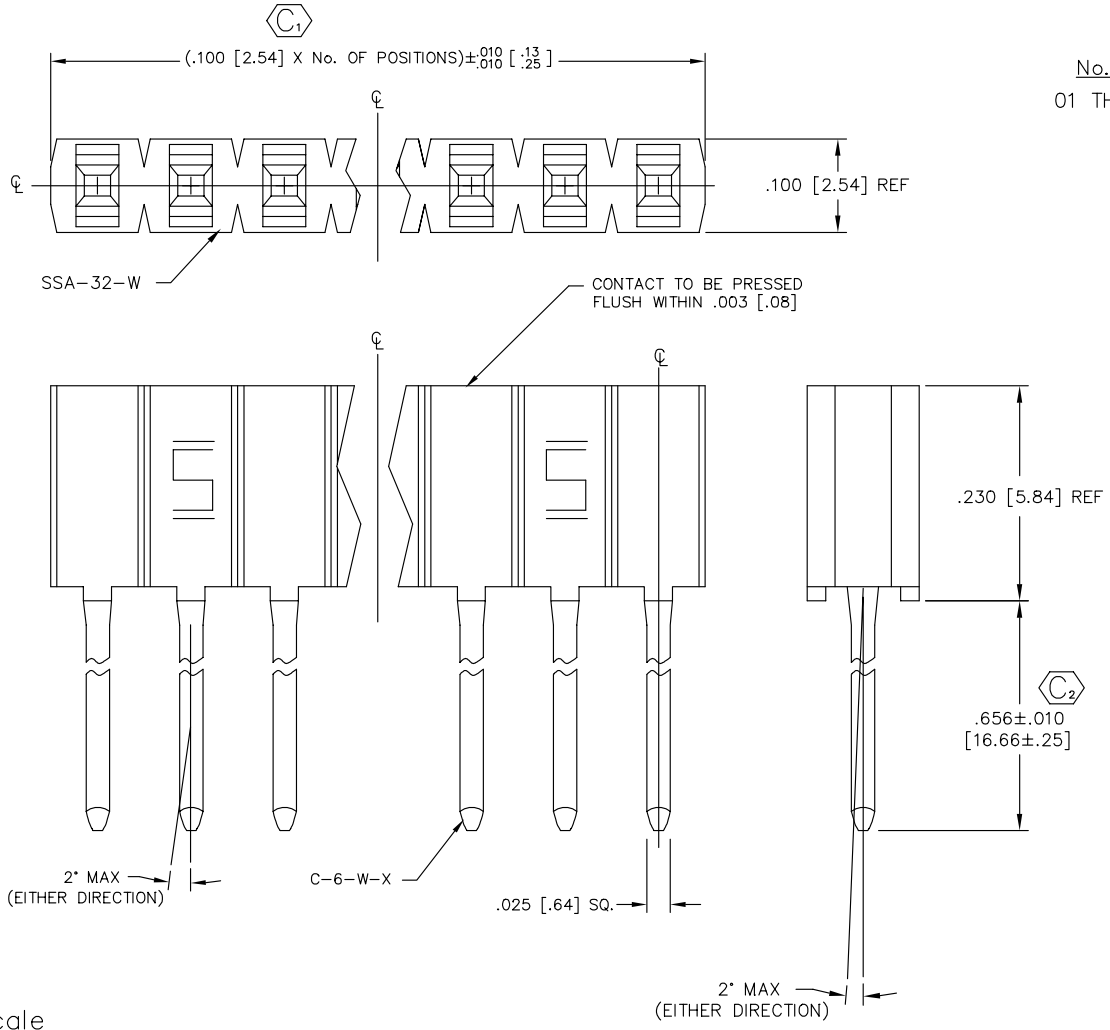

SSA-1XX-W-X-XX

No. OF POSITIONS _____
01 THRU 32 AVAILABLE

LEAD STYLE: _____
WIRE WRAP CONTACT
C-6-W-X

CONTACT PLATING _____
-G: GOLD
-T: TIN

OPTION _____
-RA: RIGHT ANGLE
(SEE FIGURE 1)

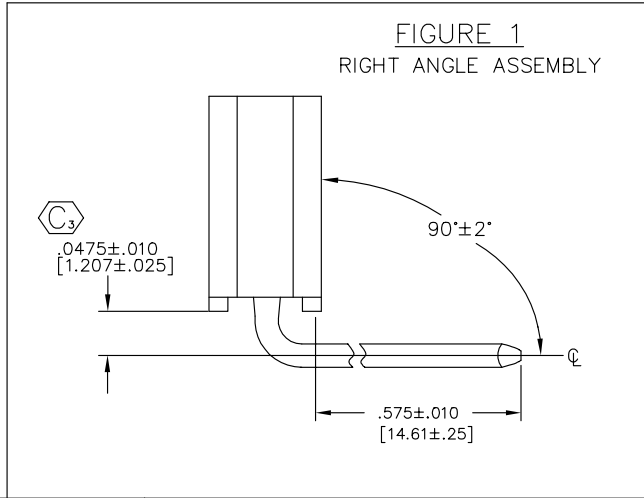

Do not scale from this print

- NOTES:
1. MINIMUM CONTACT PUSH-OUT FORCE: 16 oz.
 2. INSERTION FORCE: 3.0 oz. AVG. PER CONTACT USING .018 [.46] DIA PIN.
 3. WITHDRAWAL FORCE: 1.5 oz. AVG. PER CONTACT USING .018 [.46] DIA PIN.
 4. C_1 REPRESENTS A CRITICAL DIMENSION.

PROPRIETARY NOTE
THIS DOCUMENT CONTAINS INFORMATION CONFIDENTIAL AND PROPRIETARY TO SAMTEC INC. AND SHALL NOT BE REPRODUCED OR TRANSFERRED TO OTHER DOCUMENTS OR DISCLOSED TO OTHERS OR USED FOR ANY PURPOSE OTHER THAN THAT FOR WHICH IT WAS OBTAINED WITHOUT THE EXPRESSED WRITTEN CONSENT OF SAMTEC INC.

MATERIAL:
INSULATOR:
DUPONT FR-530 RYNITE
CONTACT:
PHOSPHOR BRONZE

samtec

520 PARK EAST BLVD. NEW ALBANY, INDIANA 47150
PHONE (812) 944-6733 P.O. BOX 1147
CODE 55322

MADE BY: MARK CHILTON 11-19-88

SSA-1XX-W-X-XX
SHEET 1 OF 1