

DO NOT SCALE FROM THIS PRINT

UNLESS OTHERWISE NOTED
 DIMENSIONS ARE IN INCHES
 TOLERANCES ARE:
 ONE PLACE DECIMALS ± .1
 TWO PLACE DECIMALS ± .01
 THREE PLACE DECIMALS ± .005
 FOUR PLACE DECIMALS ± .0020
 ANGLES ± 2°

TITLE: .050 X .050
 SOCKET STRIP
 DOUBLE ROW ASSEMBLY

DWG NO: SFC-1XX-XX-XX-D-XX
 SHEET 1 OF 2

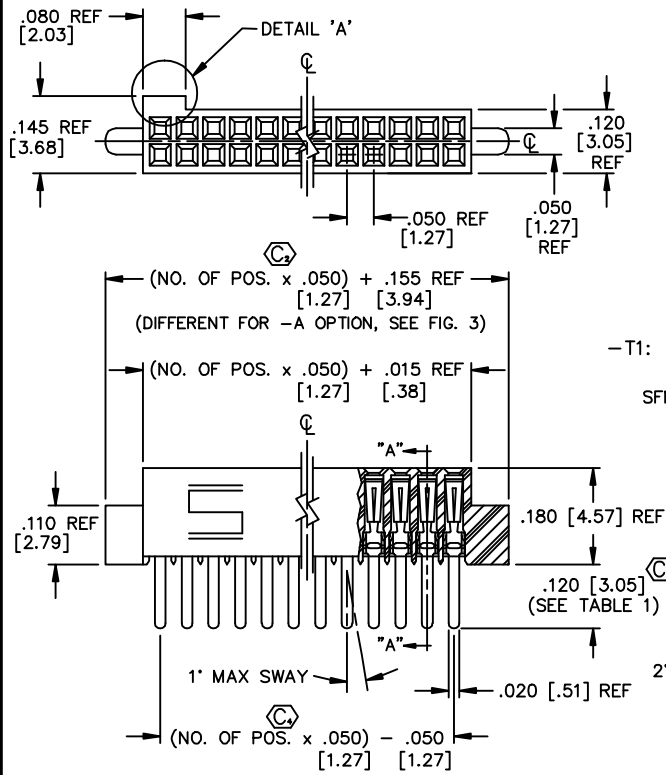

- NOTES:
1. MIN. PUSHOUT FORCE: .5 lb.
 2. COPLANARITY: .004=POS 05 THRU 26
.006=POS 27 THRU 50
 3. (C) REPRESENTS CRITICAL DIMENSION
 4. TUBE ALL POSITIONS.
 5. PINS CAN BE ORIENTED IN ANY DIRECTION; BOTH ROWS MUST FACE SAME WAY.
 6. SEE NOTCH FOR PROPER ORIENTATION.

FIG. 1

-T1: THROUGH HOLE/STRAIGHT MODIFIED

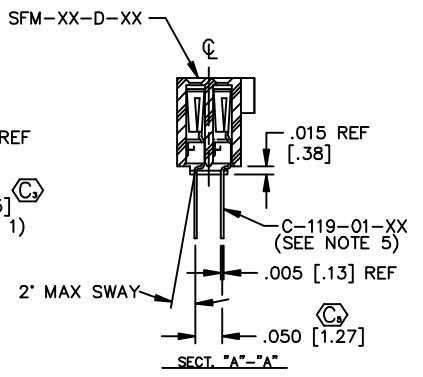

SFC-1XX-XX-XX-D-XX

NO. OF POSITIONS
 ALL POSITIONS AVAILABLE
 -5 THRU -50
 USE BODY: (SFM-XX-D-XX)

LEAD STYLE

- T1: THROUGH HOLE (PHOS BRONZE)
USE CONTACT: (C-119-01-XX)
(SEE FIG. 1, SHT. 1)
- T2: SURFACE MOUNT (PHOS BRONZE)
USE CONTACT: (C-119-02-XX)
(SEE FIG. 2, SHT. 1)

- OPTIONS
 (LEAVE BLANK FOR STANDARD AND USE SFM-XX-D)
 -A: ALIGNMENT PIN (USE SFM-XX-D-A)
(SEE FIGURE 5, SHT. 2)
 -LC: LOCKING CLIP (SEE FIGURE 6)
(USE (2) LC-05-TM & SFM-XX-D-LC)
(AVAILABLE ON ALL LEADS)
 -TR: TAPE & REEL
(SEE FIG 4, SHT. 2)
 -K: POLYAMIDE FILM PAD (.005 [.13]
THICKNESS WITH SILICONE ADHESIVE)
(SEE FIG 3) (USE K-500-300)

PLATING SPECIFICATION

- F: FLASH SELECTIVE GOLD
- L: LIGHT SELECTIVE GOLD
- FM: FLASH SELECTIVE GOLD/MATTE TIN TAILS
- LM: LIGHT SELECTIVE GOLD/MATTE TIN TAILS

BODY SPECIFICATION

- D: DOUBLE ROW

TABLE 1

SUFFIX	TAIL LENGTH "A"	TAIL WIDTH "B"
-T1	.120 [3.05]	.020 [.51]

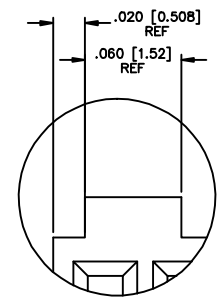

DETAIL 'A'
 (ALTERNATE CONSTRUCTION)
 SCALED 3x

DIFFERENT AS SHOWN OTHERWISE SAME AS FIG. 1

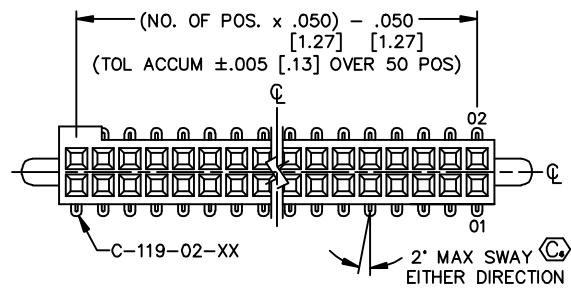

FIG. 2

-T2: SURFACE MOUNT

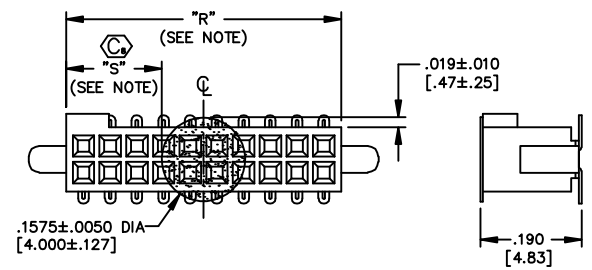
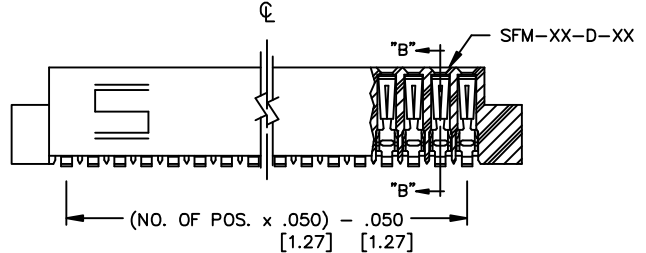
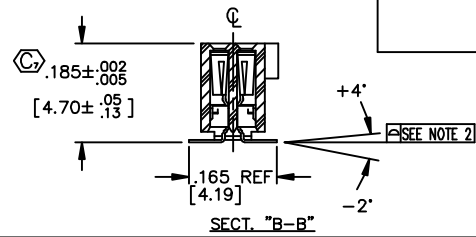

FIGURE 3

-K: POLYAMIDE FILM PAD

NOTE: "R" = USED MEASURED DIMENSION (REF)
 "S" = {("R" - .1575 [4.00])/2}±.020 [.51]



SECT. "B-B"

PROPRIETARY NOTE
 THIS DOCUMENT CONTAINS INFORMATION CONFIDENTIAL AND PROPRIETARY TO SAMTEC INC. AND SHALL NOT BE REPRODUCED OR TRANSFERRED TO OTHER DOCUMENTS OR DISCLOSED TO OTHERS OR USED FOR ANY PURPOSE OTHER THAN THAT FOR WHICH IT WAS OBTAINED WITHOUT THE EXPRESSED WRITTEN CONSENT OF SAMTEC INC.

samtec

520 PARK EAST BLVD. NEW ALBANY, INDIANA 47150
 PHONE (812) 944-6733 P.O. BOX 1147
 CODE 55322

MADE BY: BRATCHER 5-25-01

SFC-1XX-XX-XX-D-XX
 SHEET 1 OF 2