

NOTES:

1. $\text{\textcircled{C}}$ REPRESENTS A CRITICAL DIMENSION.
2. MINIMUM PUSHOUT FORCE: .5 LB.
3. COPLANARITY: .004[0.10] = POS 05 THRU 26
.006[0.15] = POS 27 THRU 50
4. TUBE ALL POSITIONS. PARTS TO BE TUBED WITH NOTCH GOING WITH ARROW.
5. PINS CAN BE ORIENTED IN ANY DIRECTION; BOTH ROWS MUST FACE SAME WAY.
6. SEE NOTCH FOR PROPER ORIENTATION.
7. MAXIMUM PIN HEIGHT VARIATION: .003[0.08].
8. DUE TO HIGH AMOUNT OF INSERTION FORCE NEEDED, THE -LC OPTION IS NOT COMPATIBLE WITH AUTO PLACEMENT. SAMTEC RECOMMENDS MANUAL PLACEMENT FOR ALL ASSEMBLIES WITH THE -LC OPTION.

DO NOT SCALE FROM THIS PRINT

SFM-1XX-XX-XXX-D-XXX

NO OF POSITIONS
ALL POSITIONS AVAILABLE
-02 THRU -50
(USE BODY: SFM-XX-D-XX-X)

OPTIONS
(LEAVE BLANK FOR STANDARD AND USE SFM-XX-D)
-N: NO POLARIZATION NOTCH (USE SFM-XX-D-XX-N)
-A: ALIGNMENT PIN (USE SFM-XX-D-A-X) (SEE FIG 4, SHT 2)
-LC: LOCKING CLIP (SEE FIG 6, SHT 3 & NOTE 8) (AVAILABLE ON ALL LEADS)
-P: PICK AND PLACE PAD (SEE FIG 5, SHT 2)
-TR: TAPE & REEL (SEE SHT 4) (NOT AVAILABLE WITH -DS OPTION)
-K: POLYIMIDE FILM PAD (.005[0.13] THICKNESS) (SEE FIG 3, SHT 2) (USE K-DOT-.157-.250-.005)
-SN: SOLDER NAIL FOR .062 BOARD (SFM-XX-D-SN AND WT-27-01-T) (AVAILABLE WITH LEAD STYLE -02, -L2 & -T2) (NOT AVAILABLE WITH -A & -LC)
-SN2: SOLDER NAIL FOR .093 BOARD (SFM-XX-D-SN AND WT-27-02-T) (AVAILABLE WITH LEAD STYLE -02, -L2 & -T2) (NOT AVAILABLE WITH -A & -LC)
-DS: DUAL SCREW DOWN FOR .062 BOARD (SEE FIG 8, SHT 3) (ONLY AVAILABLE WITH -01, -02 AND -03 LEAD STYLE, 02 THRU 40 POSITIONS) (NOT AVAILABLE WITH OPTIONS -N, -A, -LC, -P, -TR, -K, -SN AND SN2), (USES SFM-XX-D-DS, CPS-RR-XX-XX-X, ACCRT-01 AND WT-27-XX-T ALWAYS FILLED)

LEAD STYLE
-01: THROUGH HOLE (USE CONTACT: C-44-01-XXX) (SEE FIG 1, SHT 1)
-02: SURFACE MOUNT (USE CONTACT: C-44-02-XXX) (SEE FIG 2, SHT 2)
-03: STRAIGHT MODIFIED (USE CONTACT: C-44-03-XXX) (SEE FIG 1, SHT 1)
-L1: THROUGH HOLE (LOW INSERTION) (USE CONTACT: C-61-01-XXX) (SEE FIG 1, SHT 1)
-L2: SURFACE MOUNT (LOW INSERTION) (USE CONTACT: C-61-02-XXX) (SEE FIG 2, SHT 2)
-L3: STRAIGHT MODIFIED (LOW INSERTION) (USE CONTACT: C-61-03-XXX) (SEE FIG 1, SHT 1)
-T1: THROUGH HOLE (PHOS BRONZE) (USE CONTACT: C-119-01-XXX) (SEE FIG 1, SHT 1)
-T2: SURFACE MOUNT (PHOS BRONZE) (USE CONTACT: C-119-02-XXX) (SEE FIG 2, SHT 2)

BODY SPECIFICATION
-D: DOUBLE ROW

*: DIMENSIONS N/A FOR -N OPTION

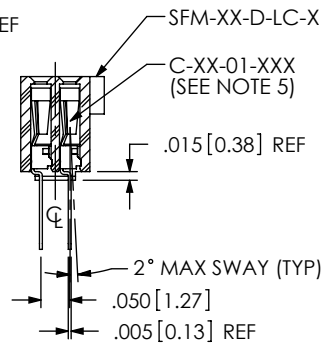
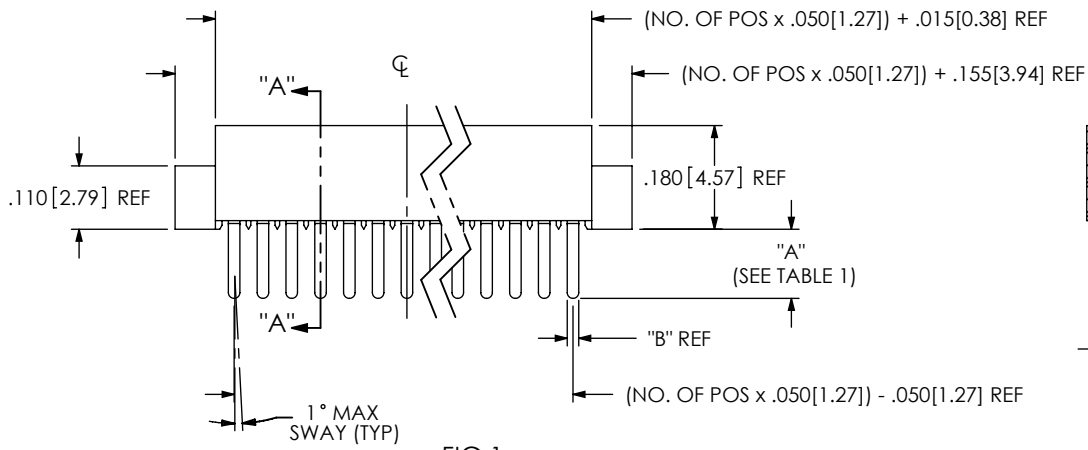
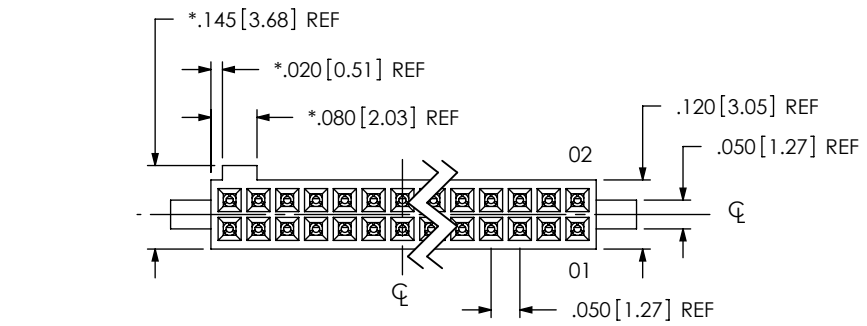

PLATING SPECIFICATION
-S: 30 μ " SELECTIVE GOLD IN CONTACT AREA, MATTE TIN ON TAIL
-F: 3 μ " FLASH SELECTIVE GOLD IN CONTACT AREA, MATTE TIN ON TAIL
-H: 30 μ " HEAVY GOLD IN CONTACT AREA, 3 μ " GOLD ON TAIL
-L: 10 μ " LIGHT SELECTIVE GOLD IN CONTACT AREA, MATTE TIN ON TAIL
-STL: 30 μ " SELECTIVE GOLD IN CONTACT AREA, TIN/LEAD (90/10+/-5%) TAIL (ONLY AVAILABLE ON -02 OR -L2 LEADSTYLES)
-SM: 30 μ " SELECTIVE GOLD IN CONTACT AREA, MATTE TIN ON TAIL
-FM: 3 μ " FLASH SELECTIVE GOLD IN CONTACT AREA, MATTE TIN ON TAIL
-LM: 10 μ " LIGHT SELECTIVE GOLD IN CONTACT AREA, MATTE TIN ON TAIL

FIG 1 THROUGH HOLE/STRAIGHT MODIFIED

TABLE 1		
SUFFIX	TAIL LENGTH "A"	TAIL WIDTH "B"
-X1	.120[3.05]	.020[0.51]
-X3	.075[1.91]	.016[0.41]

UNLESS OTHERWISE SPECIFIED, DIMENSIONS ARE IN INCHES.
TOLERANCES ARE:
DECIMALS ANGLES
.XX: $\pm .01$ [.3] 2°
.XXX: $\pm .005$ [.13]
.XXXX: $\pm .0020$ [.051]

PROPRIETARY NOTE
THIS DOCUMENT CONTAINS INFORMATION CONFIDENTIAL AND PROPRIETARY TO SAMTEC, INC. AND SHALL NOT BE REPRODUCED OR TRANSFERRED TO OTHER DOCUMENTS OR DISCLOSED TO OTHERS OR USED FOR ANY PURPOSE OTHER THAN THAT WHICH IT WAS OBTAINED WITHOUT THE EXPRESSED WRITTEN CONSENT OF SAMTEC, INC.



520 PARK EAST BLVD, NEW ALBANY, IN 47150
PHONE: 812-944-6733 FAX: 812-948-5047
e-Mail: info@SAMTEC.com code 55322

MATERIAL: DO NOT SCALE DRAWING SHEET SCALE: 3:1
INSULATOR: LCP, COLOR: BLACK
CONTACT: TIGER EYE = BeCu
TIGER EYE LITE = PHOSPHOR BRONZE

DESCRIPTION:
.050 x .050 SOCKET STRIP DOUBLE ROW ASSEMBLY

DWG. NO.
SFM-1XX-XX-XXX-D-XXX

BY: JORDAN 12/11/89 SHEET 1 OF 4

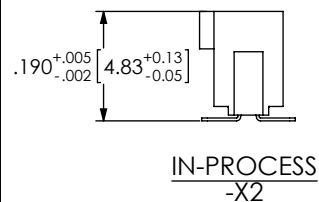
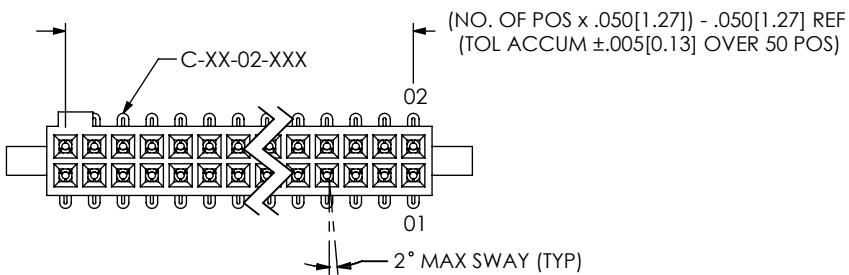

FOR HAND FILL ONLY
NOTE: DIMENSION APPLIES PRIOR TO RE-PRESS, SEE SECTION "B-B" FOR FINISHED DIMENSION

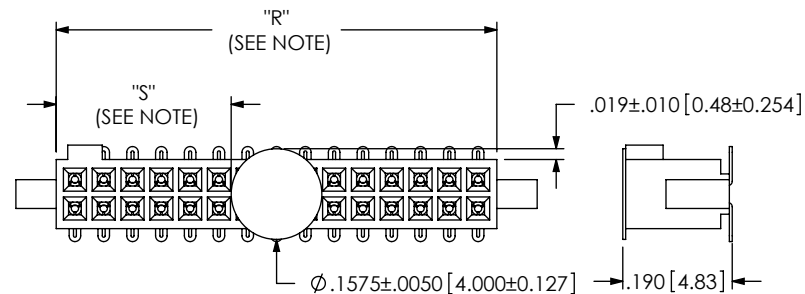

FIG 3
-K: POLYIMIDE FILM PAD
(SAME AS FIG 1, DIFFERENT AS SHOWN)
NOTE: "R" = USED MEASURED DIMENSION REF
"S" = $\{("R" - .1575[4.000])/2\} \pm .020[0.51]$

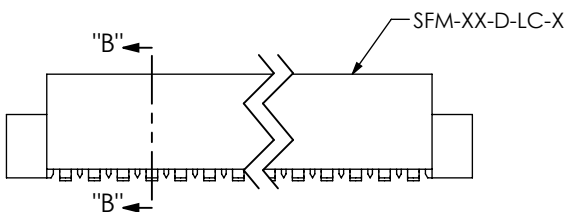

FIG 2
-X2: SURFACE MOUNT
(SAME AS FIG 1, DIFFERENT AS SHOWN)

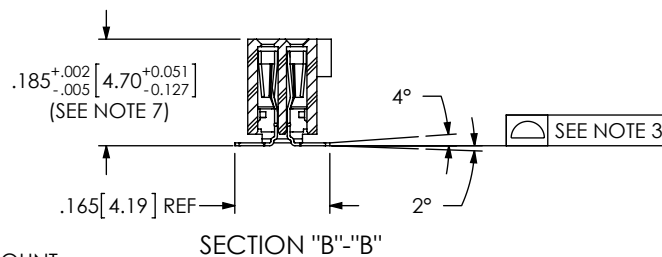

TABLE 2	
POS.	"A"
ODD	$\{(No. OF POS \times .050[1.27])/2\} - .1895[4.813]$
EVEN	$\{(No. OF POS \times .050[1.27])/2\} - .2145[5.448]$

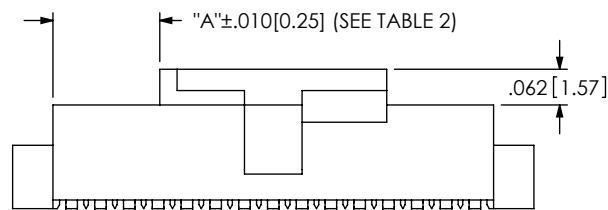
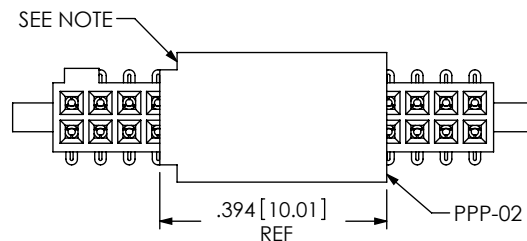

FIG 5
-P: PICK AND PLACE PAD
(PAD TO BE ORIENTED AS SHOWN FOR 5-12 POSITION PARTS)
(FOR 13-50 POSITION PARTS, PAD MAY BE ORIENTED IN EITHER DIRECTION)
(SAME AS FIG 1, DIFFERENT AS SHOWN)

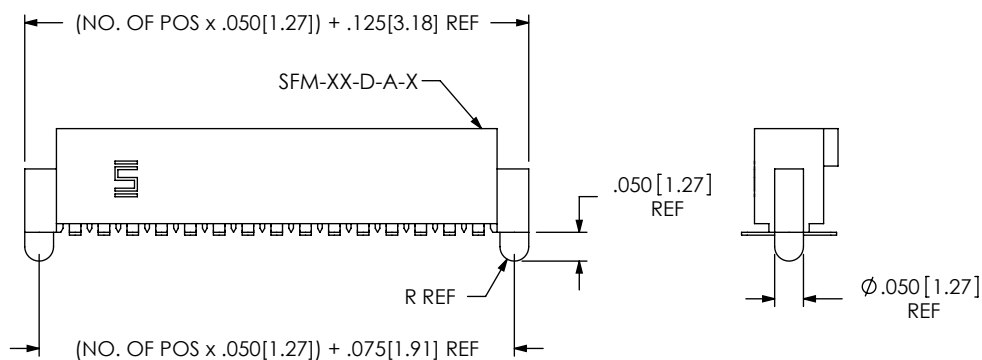

FIG 4
-A: ALIGNMENT PIN
(SAME AS FIG 1, DIFFERENT AS SHOWN)

PROPRIETARY NOTE
THIS DOCUMENT CONTAINS INFORMATION CONFIDENTIAL AND PROPRIETARY TO SAMTEC, INC. AND SHALL NOT BE REPRODUCED OR TRANSFERRED TO OTHER DOCUMENTS OR DISCLOSED TO OTHERS OR USED FOR ANY PURPOSE OTHER THAN THAT WHICH IT WAS OBTAINED WITHOUT THE EXPRESSED WRITTEN CONSENT OF SAMTEC, INC.

DO NOT SCALE DRAWING

SHEET SCALE: 3:1

samtec

520 PARK EAST BLVD, NEW ALBANY, IN 47150
PHONE: 812-944-6733 FAX: 812-948-5047
e-Mail info@SAMTEC.com code 55322

DESCRIPTION:
.050 x .050 SOCKET STRIP DOUBLE ROW ASSEMBLY

DWG. NO.
SFM-1XX-XX-XXX-D-XXX

BY: JORDAN 12/11/89 SHEET 2 OF 4

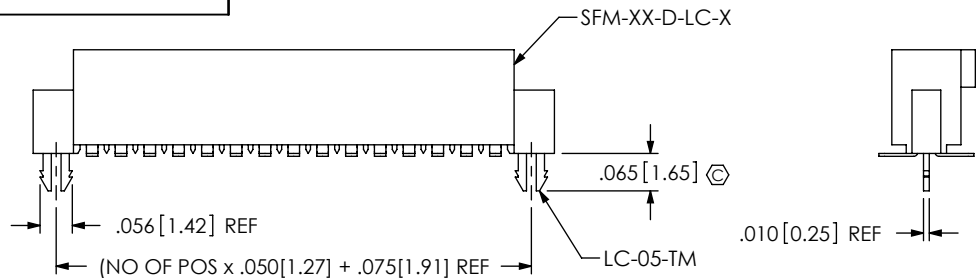
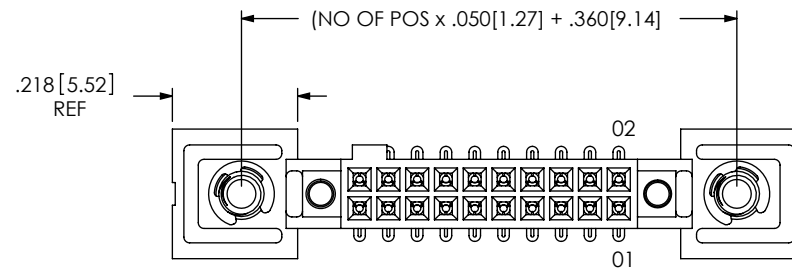
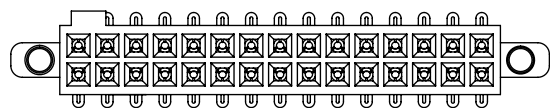
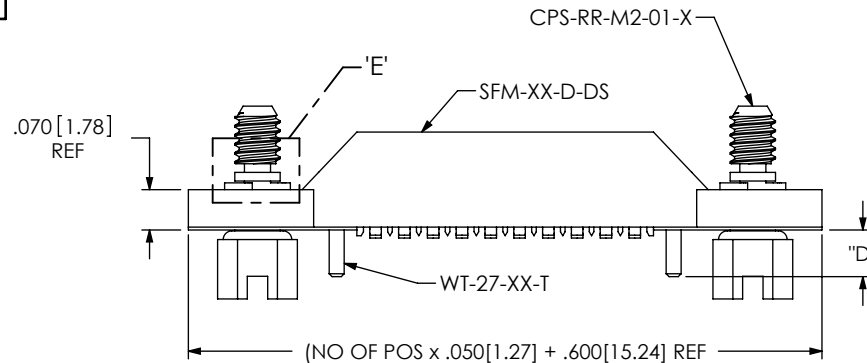
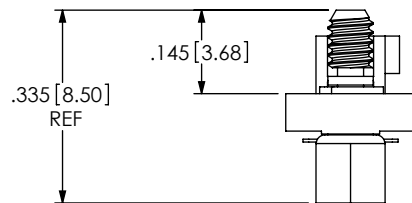

FIG 6
-LC: LOCKING CLIP
(SAME AS FIG 1, DIFFERENT AS SHOWN)
(AVAILABLE IN ALL LEADS)



LEAD STYLE	"D"	WT-27
-01	.081	-01
-02	.081	-01
-03	.115	-02



OPTION	"C"
-SN	.076 [1.93]
-SN2	.110 [2.79]

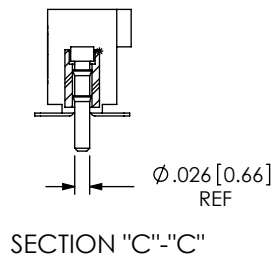
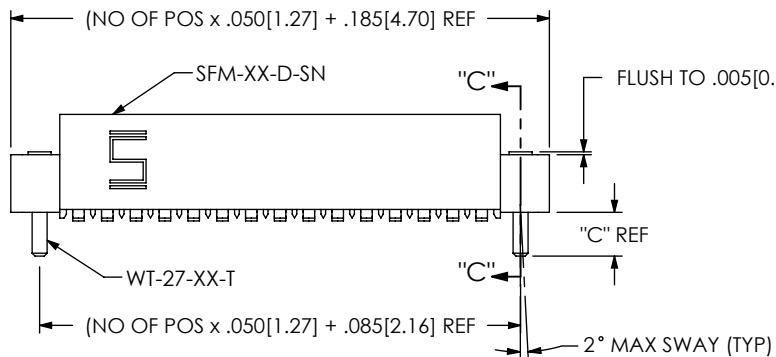

FIG 7
-SNX: SOLDER NAIL
(SAME AS FIG 1, DIFFERENT AS SHOWN)

F:\DWG\MISC\MKTG\SFM-1XX-XX-XXX-D-XXX-MKT.SLDDRW

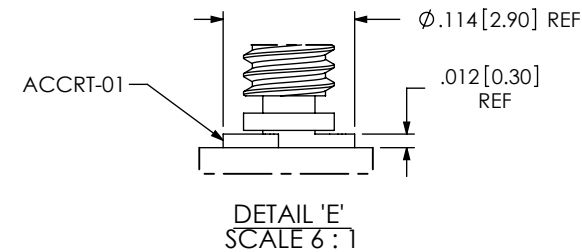

FIG 8
-DS: DUAL SCREW DOWN
(SAME AS FIG 2, DIFFERENT AS SHOWN)

PROPRIETARY NOTE
THIS DOCUMENT CONTAINS INFORMATION CONFIDENTIAL AND PROPRIETARY TO SAMTEC, INC. AND SHALL NOT BE REPRODUCED OR TRANSFERRED TO OTHER DOCUMENTS OR DISCLOSED TO OTHERS OR USED FOR ANY PURPOSE OTHER THAN THAT WHICH IT WAS OBTAINED WITHOUT THE EXPRESSED WRITTEN CONSENT OF SAMTEC, INC.

DO NOT SCALE DRAWING
SHEET SCALE: 3:1



520 PARK EAST BLVD, NEW ALBANY, IN 47150
PHONE: 812-944-6733 FAX: 812-948-5047
e-Mail: info@SAMTEC.com code 55322

DESCRIPTION:
.050 x .050 SOCKET STRIP DOUBLE ROW ASSEMBLY
DWG. NO.
SFM-1XX-XX-XXX-D-XXX

BY: JORDAN 12/11/89 SHEET 3 OF 4

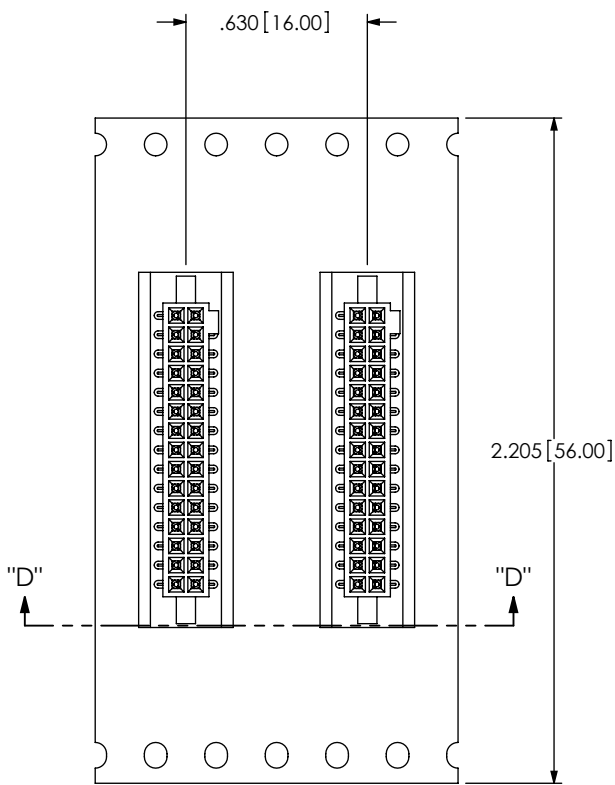

UNWINDING DIRECTION →

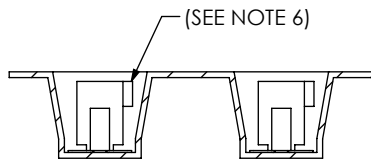

SECTION "D"-"D"
SCALE 2 : 1

PACKAGING VIEW
-TR: TAPE AND REEL

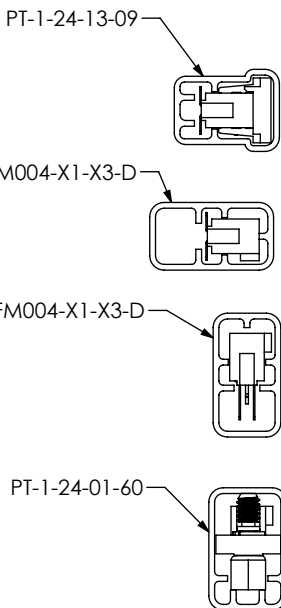

PACKAGING VIEW
PACKAGE PARTS IN TUBES AS SHOWN (SEE NOTE 4)

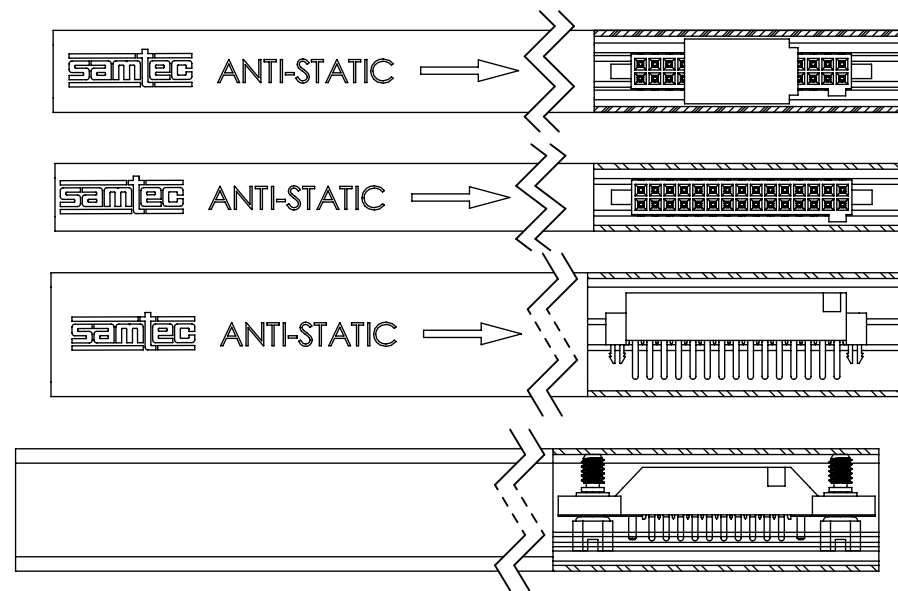

LEAD STYLE	PACKAGING TUBE	PLUG
-105-X2-X-D, -105X2-X-D-LC, -105-X2-D-A, -105-X2-D-K-LC	PT-1-24-14-09	TP-24-02
-X1-D, -X3-D, -X1-D-LC, -X3-D-LC, (NO P&P PAD), D-A, -X3-D-A, -X1-D-K, -X3-D-K	X1-PT-SFM004-X1-X3-D	TP-24-02
-X1-D-P, -X1-D-LC-P (WITH P&P PAD), X1-D-A-P	PT-1-24-02-17	TP-09
-X2-D, -X2-D-K, -X2-D-LC (NO P&P PAD), -X2-D-A, -X2-D-K-A, -X2-D-LC-K, -X2-D-SNX	PT-SFM004-X1-X3-D	TP-24-02
-X2-D-P, -X3-D-P, -X2-D-LC-P (WITH P&P PAD), -X2-D-A-P, -X3-D-A-P, -X2-D-P-SNX	PT-1-24-13-09	TP-24
-01-DS, -02-DS, -03-DS	PT-1-24-01-60	TP-03

*FOR MACHINE LOADING OF TUBES FOR PARTS W/O PADS USE PT-1-24-14-09,
W/PADS USE PT-1-24-13-09

5 POS -01 AND -03 LEAD STYLES MAY BE TUBED USING
PT-1-24-15-09, TP-24-02

F:\DWG\MISC\MKTG\SFM-1XX-XX-XXX-D-XXX-MKT.SLDDRW

PROPRIETARY NOTE

THIS DOCUMENT CONTAINS INFORMATION CONFIDENTIAL AND PROPRIETARY TO SAMTEC, INC. AND SHALL NOT BE REPRODUCED OR TRANSFERRED TO OTHER DOCUMENTS OR DISCLOSED TO OTHERS OR USED FOR ANY PURPOSE OTHER THAN THAT WHICH IT WAS OBTAINED WITHOUT THE EXPRESSED WRITTEN CONSENT OF SAMTEC, INC.

DO NOT SCALE DRAWING

SHEET SCALE: 1.5:1



520 PARK EAST BLVD, NEW ALBANY, IN 47150
PHONE: 812-944-6733 FAX: 812-948-5047
e-Mail info@SAMTEC.com code 55322

DESCRIPTION:
.050 x .050 SOCKET STRIP DOUBLE ROW ASSEMBLY

DWG. NO.
SFM-1XX-XX-XXX-D-XXX

BY: JORDAN 12/11/89 SHEET 4 OF 4