

NOTES:

1. MINIMUM PUSHOUT FORCE: .5 LB.
2. NOTE DELETED.
3. Ⓞ REPRESENTS A CRITICAL DIMENSION.
4. NOTE DELETED.
5. DUE TO THE HIGH AMOUNT OF INSERTION FORCE NEEDED, THE -LC OPTION IS NOT COMPATIBLE WITH AUTO PLACEMENT. SAMTEC RECOMMENDS MANUAL PLACEMENT FOR ALL ASSEMBLIES WITH THE -LC OPTION.
6. TO BE MEASURED FROM A DATUM LINE MADE BY THE INSULATOR.

DO NOT SCALE FROM THIS PRINT

SFMH-1XX-XX-XXX-D-XX-XX

No OF POSITIONS PER ROW -05 THRU -50

PACKAGING OPTIONS -TR: TAPE & REEL

LEAD STYLE -02

PLATING SPECIFICATION (VALUES GIVEN ARE IN MICRO-INCHES)

- L: 10μ" GOLD IN CONTACT AREA, GOLD FLASH ON TAIL (USE C-108-G & C-109-G)
- F: 3μ" GOLD IN CONTACT AREA, GOLD FLASH ON TAIL (USE C-108-FG & C-109-FG)
- S: 30μ" GOLD IN CONTACT AREA, MATTE TIN ON TAIL (USE C-108-S & C-109-S)
- LM: 10μ" GOLD IN CONTACT AREA, MATTE TIN ON TAIL (USE C-108-LM & C-109-LM)
- STL: 30μ" GOLD IN CONTACT AREA, TIN/LEAD ((90/10+/-5%)TAIL (USE C-108-STL & C-109-STL)
- FTL: 3μ" GOLD IN CONTACT AREA, TIN/LEAD ((90/10+/-5%) TAIL (USE C-108-FTL & C-109-FTL)
- LTL: 10μ" GOLD IN CONTACT AREA, TIN/LEAD ((90/10+/-5%) TAIL (USE C-108-LTL & C-109-LTL)

OPTIONS

- LC: LOCKING CLIP (SEE FIG 1, SHT 1) (NOT AVAILABLE W/ -WT OPTION) (SEE NOTE 5)
- *-SL: SOLDER LOCK (SEE FIG 2, SHT 2)
- WT: WELD TAB (SEE FIG. 3, SHT 2) (NOT AVAILABLE W/ -LC OPTION) (AVAILABLE ON POSITIONS -05 THRU -30)

ROW SPECIFICATION -D: DOUBLE ROW

* NOT TOOLED

SEE PP-C-108-XXX & PP-C-109-XXX FOR PLATING DETAILS.

FIG 1 SFMH-110-02-XXX-D-LC SHOWN

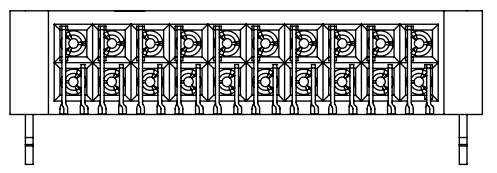
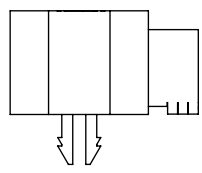
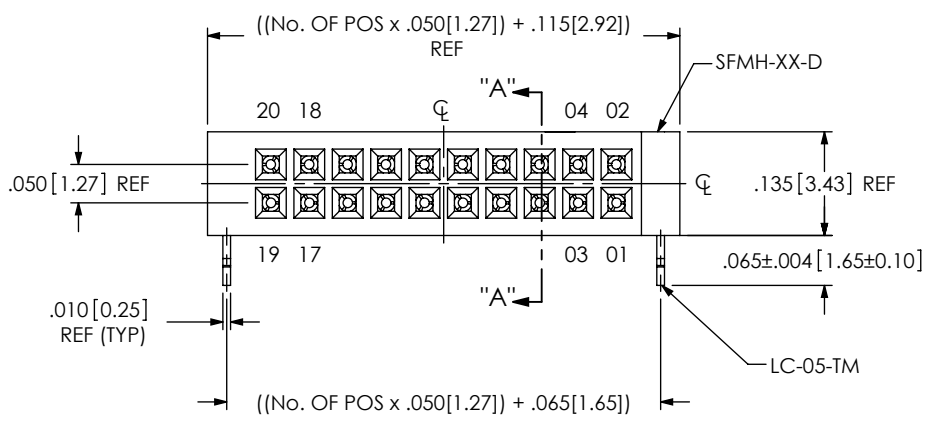
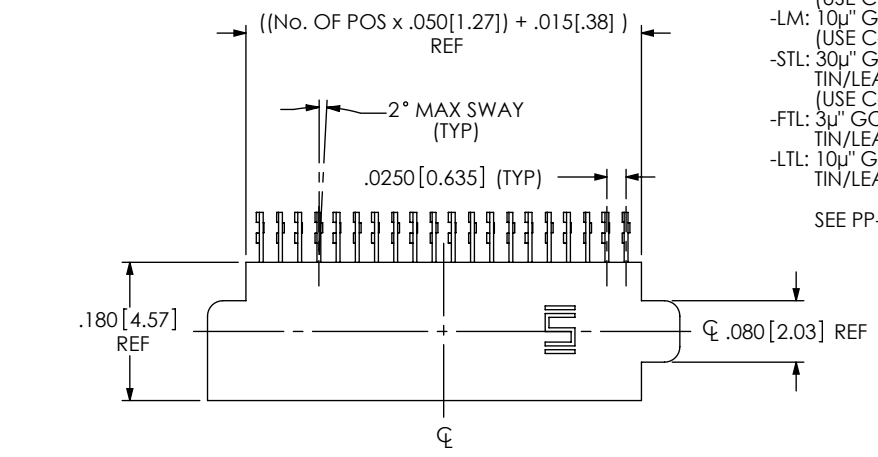

UNLESS OTHERWISE SPECIFIED, DIMENSIONS ARE IN INCHES. TOLERANCES ARE:
 DECIMALS ANGLES
 .XX: $\pm .01$ [.3] $\pm 5^\circ$
 .XXX: $\pm .005$ [.13]
 .XXXX: $\pm .0020$ [.051]

PROPRIETARY NOTE
 THIS DOCUMENT CONTAINS INFORMATION CONFIDENTIAL AND PROPRIETARY TO SAMTEC, INC. AND SHALL NOT BE REPRODUCED OR TRANSFERRED TO OTHER DOCUMENTS OR DISCLOSED TO OTHERS OR USED FOR ANY PURPOSE OTHER THAN THAT WHICH IT WAS OBTAINED WITHOUT THE EXPRESSED WRITTEN CONSENT OF SAMTEC, INC.



520 PARK EAST BLVD., NEW ALBANY, IN 47150
 PHONE: 812-944-6733 FAX: 812-948-5047
 e-Mail: info@SAMTEC.com code 55322

MATERIAL: DO NOT SCALE DRAWING SHEET SCALE: 2:1
 INSULATOR: LCP, UL 94 VO, COLOR: BLACK
 CONTACT: PHOS BRONZE

DESCRIPTION: .050 x .050 SOCKET STRIP ASSEMBLY
 DWG. NO. SFMH-1XX-XX-XXX-D-XX-XX

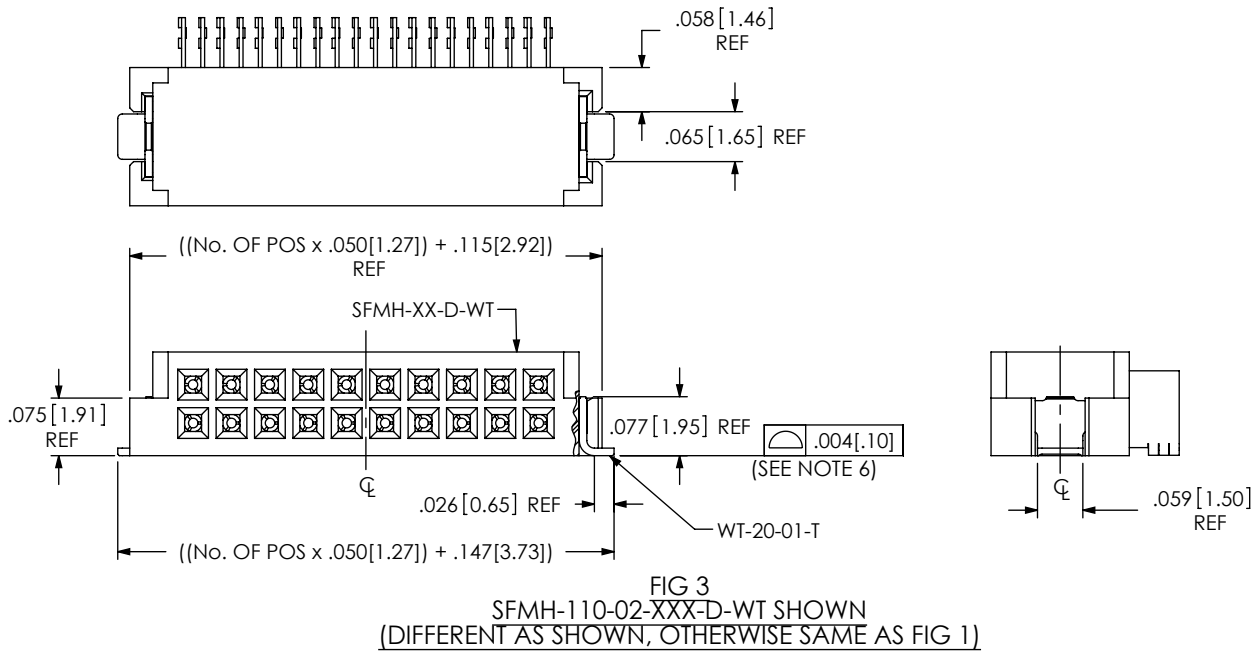
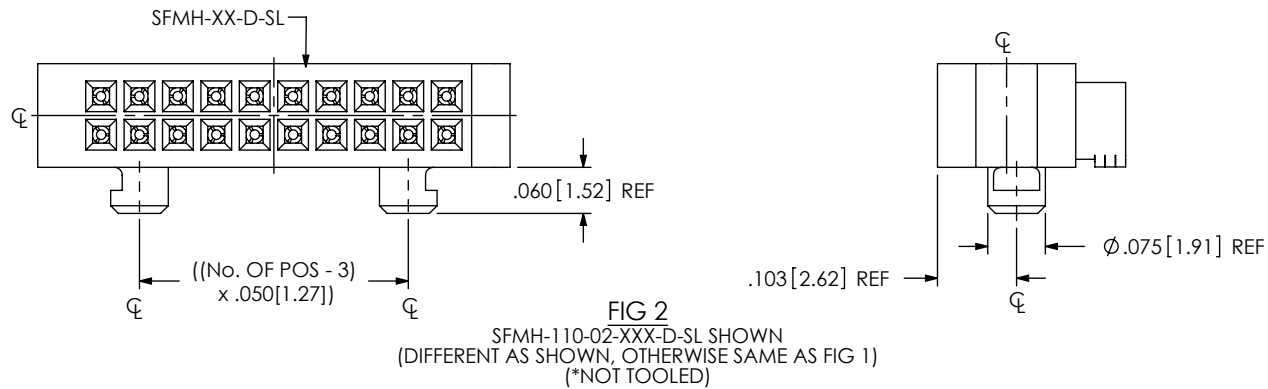
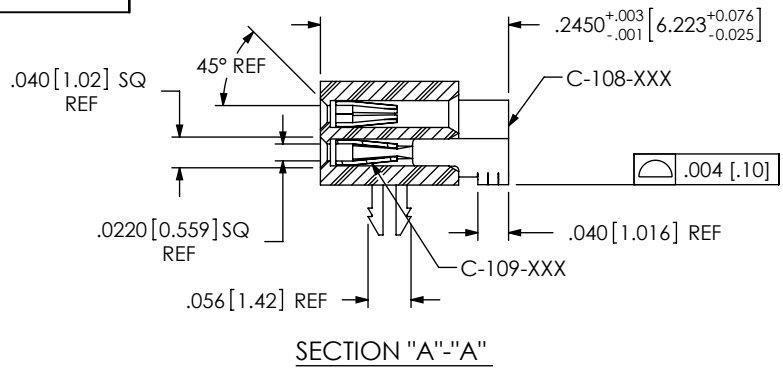

F:\DWG\MISC\MKTG\SFMH-1XX-XX-XXX-D-XX-XX-MKT.SLDDRW

PROPRIETARY NOTE
THIS DOCUMENT CONTAINS INFORMATION CONFIDENTIAL AND PROPRIETARY TO SAMTEC, INC. AND SHALL NOT BE REPRODUCED OR TRANSFERRED TO OTHER DOCUMENTS OR DISCLOSED TO OTHERS OR USED FOR ANY PURPOSE OTHER THAN THAT WHICH IT WAS OBTAINED WITHOUT THE EXPRESSED WRITTEN CONSENT OF SAMTEC, INC.



520 PARK EAST BLVD, NEW ALBANY, IN 47150
PHONE: 812-944-6733 FAX: 812-948-5047
e-Mail: info@SAMTEC.com code 55322

DO NOT SCALE DRAWING

SHEET SCALE: 2:1

DESCRIPTION: .050 x .050 SOCKET STRIP ASSEMBLY

DWG. NO. SFMH-1XX-XX-XXX-D-XX-XX

BY: J. BROWNING 12/07/2009 SHEET 2 OF 3

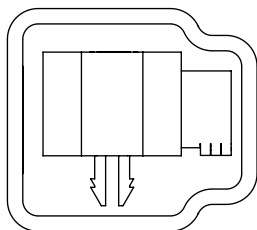

TUBE VIEW
 USE TUBE PT-1-24-01-38
 USE PLUG TP-24 (2)

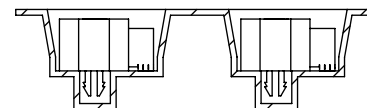
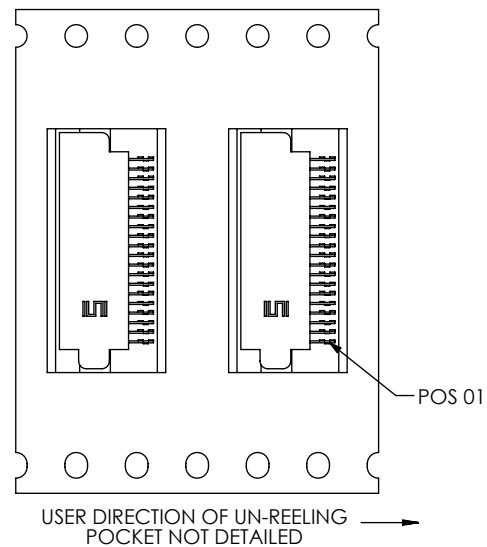

TAPE & REEL VIEW

F:\DWG\MISC\MKTG\SFMH-1XX-XX-XXX-D-XX-XX-MKT.SLDDRW

PROPRIETARY NOTE
 THIS DOCUMENT CONTAINS INFORMATION
 CONFIDENTIAL AND PROPRIETARY TO
 SAMTEC, INC. AND SHALL NOT BE REPRODUCED
 OR TRANSFERRED TO OTHER DOCUMENTS OR
 DISCLOSED TO OTHERS OR USED FOR ANY
 PURPOSE OTHER THAN THAT WHICH IT WAS
 OBTAINED WITHOUT THE EXPRESSED WRITTEN
 CONSENT OF SAMTEC, INC.

DO NOT SCALE DRAWING

SHEET SCALE: 2:1

	
520 PARK EAST BLVD, NEW ALBANY, IN 47150 PHONE: 812-944-6733 FAX: 812-948-5047 e-Mail info@SAMTEC.com code 55322	
DESCRIPTION:	
.050 x .050 SOCKET STRIP ASSEMBLY	
DWG. NO.	
SFMH-1XX-XX-XXX-D-XX-XX	
BY: J. BROWNIN	07/2009
SHEET 3 OF 3	