

REVISION AS

DO NOT SCALE FROM THIS PRINT

DIMENSIONS ARE IN INCHES		UNLESS OTHERWISE NOTED		TOLERANCES ARE:		TITLE:		DWG NO:	
ONE PLACE DECIMALS: ± .1	THREE PLACE DECIMALS: ± .005	ANGLES	± 1°		2 mm SOCKET STRIP		SMM-1XX-XX-XX-D-XX-XX-X-XX		SHEET 1 OF 2
TWO PLACE DECIMALS: ± .01	FOUR PLACE DECIMALS: ± .0020								

FIG. 1  
-01: THROUGH HOLE

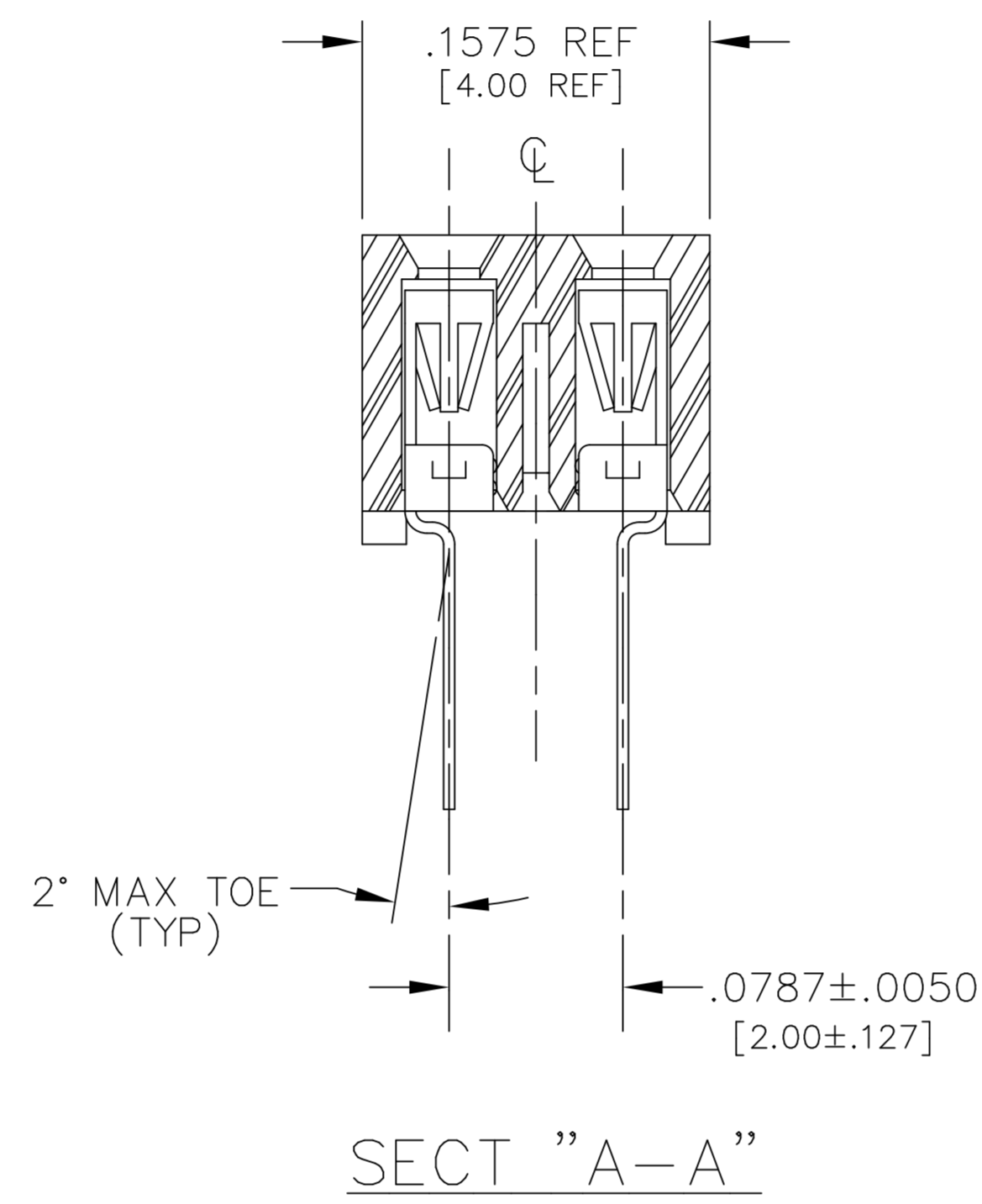
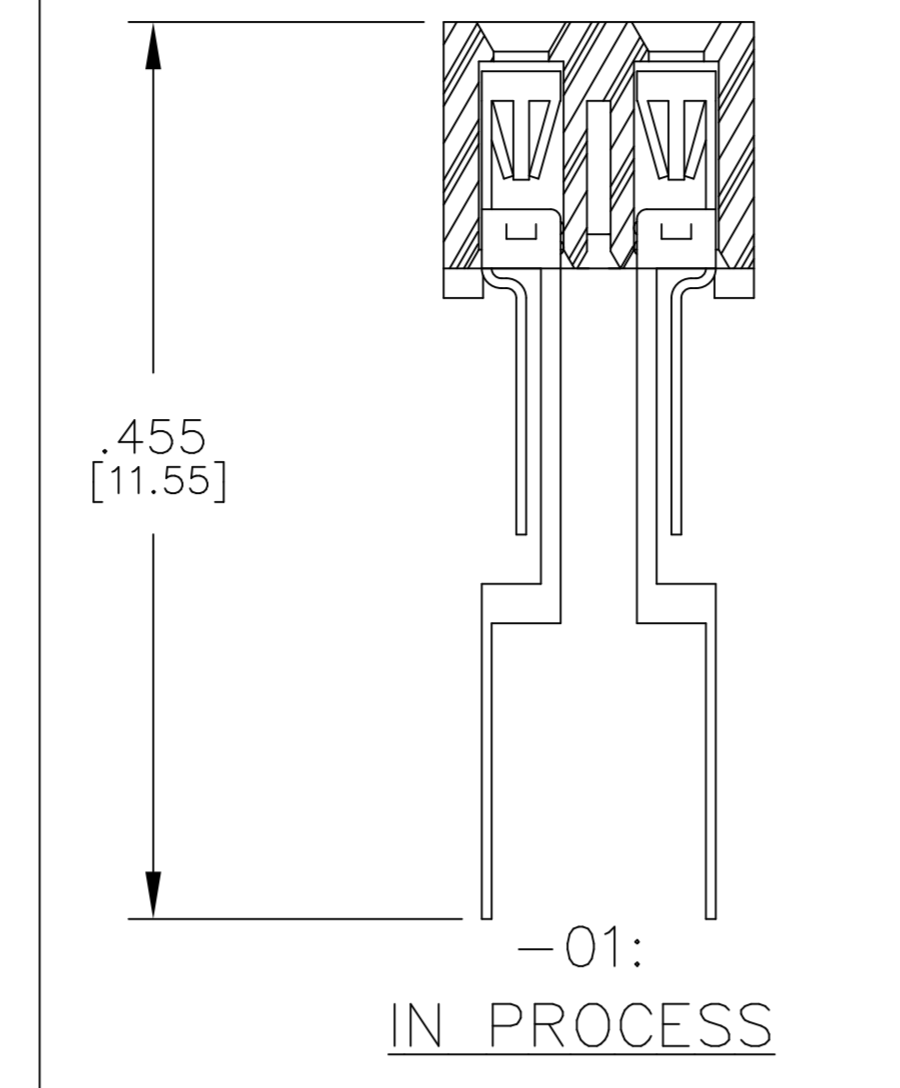
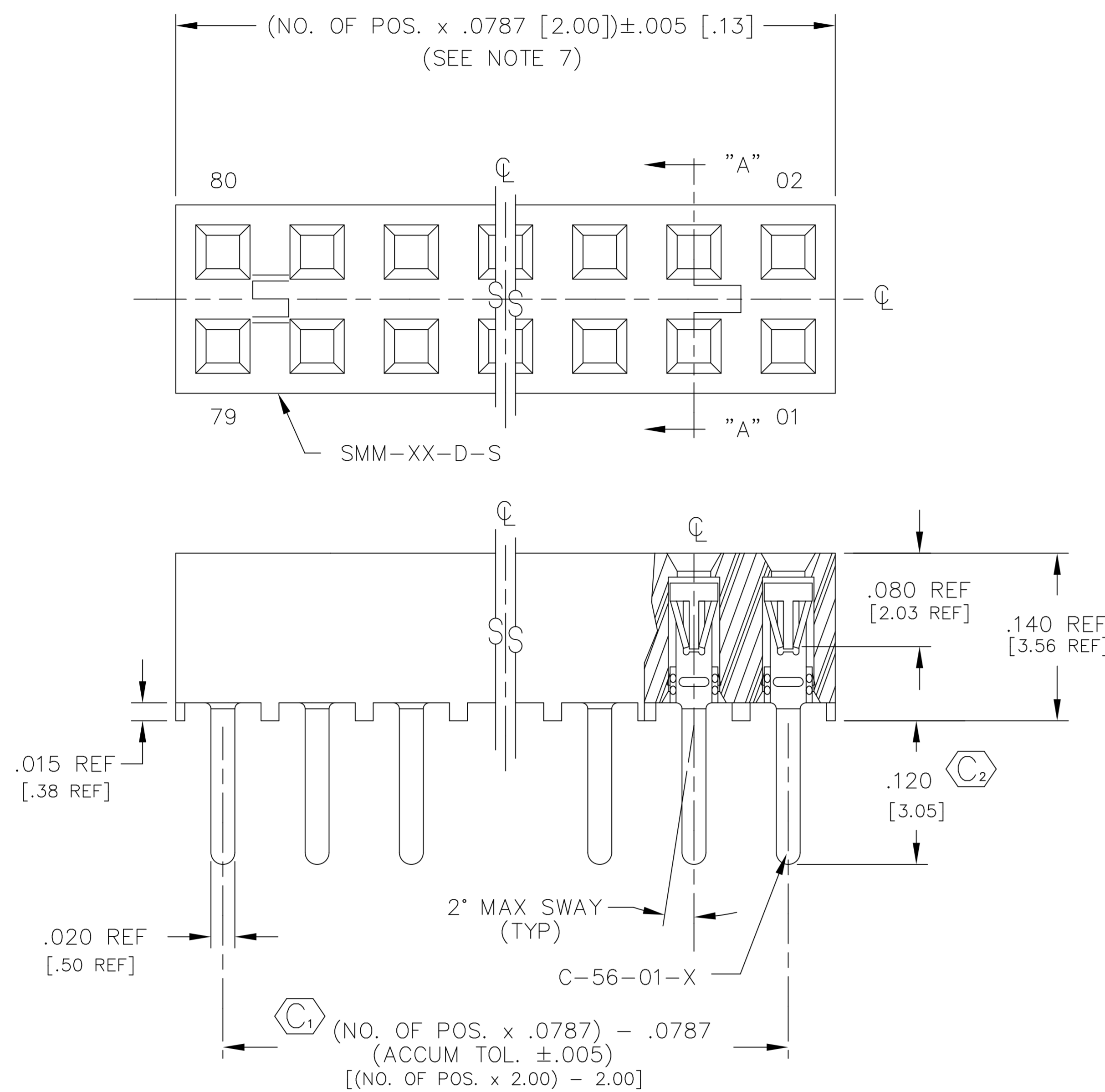

- NOTES:
- RETENTION FORCE IN BODY TO BE: 1 lbs. MIN
  - INSERTION FORCE TO BE: 3.0 oz. MAX.
  - WITHDRAWAL FORCE TO BE: 0.5 oz. MIN.
  - Ⓢ REPRESENTS CRITICAL DIMS. FOR STATISTICAL PROCESS CONTROL.
  - [ ] DIMS ARE IN METRIC AND ARE NOT CONTROLLING DIMS.
  - "-LC" OPTION FOR A 02 POSITION WILL HAVE ONLY ONE LOCKING CLIP (LC-05-T).
  - "END WALLS" AFTER CUTTING SHOULD BE .017 ± .005.
  - FOR -01 LEAD STYLE, LAYER PACKAGE POSITIONS -01 THRU -04.
  - FOR -02 LEAD STYLE WITHOUT PICK & PLACE PAD, LAYER PACKAGE POSITION -02 ONLY.
  - 02 THRU -05 POSITION WITH -K OR -P TO BE PACKAGED IN -TR ONLY. -06 THRU -40 POSITION AVAILABLE IN TUBE OR -TR PACKAGING.
  - .010" MAX CUT FLASH.
  - NO FLASH ALLOWED IN SOCKET OR EXTENDING BELOW LEADS.
  - DUE TO THE HIGH AMOUNT OF INSERTION FORCE NEEDED, THE -LC OPTION IS NOT COMPATIBLE WITH AUTO PLACEMENT. SAMTEC RECOMMENDS MANUAL PLACEMENT FOR ALL ASSEMBLIES WITH THE -LC OPTION.
  - INSULATOR MATERIAL: BLACK, LCP, UL 94 VO

LEAD STYLE		NO. OF POS. PER ROW		OPTION	
-01: THROUGH HOLE (C-56-01-X)	-02: SURFACE MOUNT (C-56-02-X)	-01: THROUGH HOLE	-02: SURFACE MOUNT	-P: PICK AND PLACE PAD (USE PPP-03) (SEE FIG 3)	-K: POLYAMIDE FILM PAD (USE K-500-300) (.005 [.13] THICKNESS WITH SILICONE ADHESIVE, SEE FIG 4) [2 POS MIN, SEE NOTE 10] (AVAILABLE ON LEAD STYLE -02 ONLY)
PLATING OPTION		ROW OPTION		POLARIZING OPTION	
-S: SELECTIVE, 30 Au / 50 Ni NICKEL, ON CONTACT, MATTE TIN TAIL	-F: FLASH SELECTIVE, 3 Au / 50 Ni MIN ON CONTACT, MATTE TIN TAIL	-D: DOUBLE ROW (USE SMM-XX-D-S)	-H: HEAVY GOLD, 30 Au / 50 Ni MIN ON CONTACT, 3 Au / 50 Ni MIN ON TAIL	-LC: LOCKING CLIP (USE 2 LC-05-TM) [AVAILABLE ONLY WITH LEAD STYLE -02, SEE * DIMS, SEE NOTE 6 & 13, SEE FIG 2]	INDICATE POSITION (USE PK-07-N)
-SM: SELECTIVE, 30 Au / 50 Ni MIN ON CONTACT, MATTE TIN TAIL	-FM: FLASH SELECTIVE, 3 Au / 50 Ni MIN ON CONTACT, MATTE TIN TAIL				
-L: LIGHT SELECTIVE, 10 Au / 50 Ni MIN ON CONTACT, MATTE TIN TAIL					

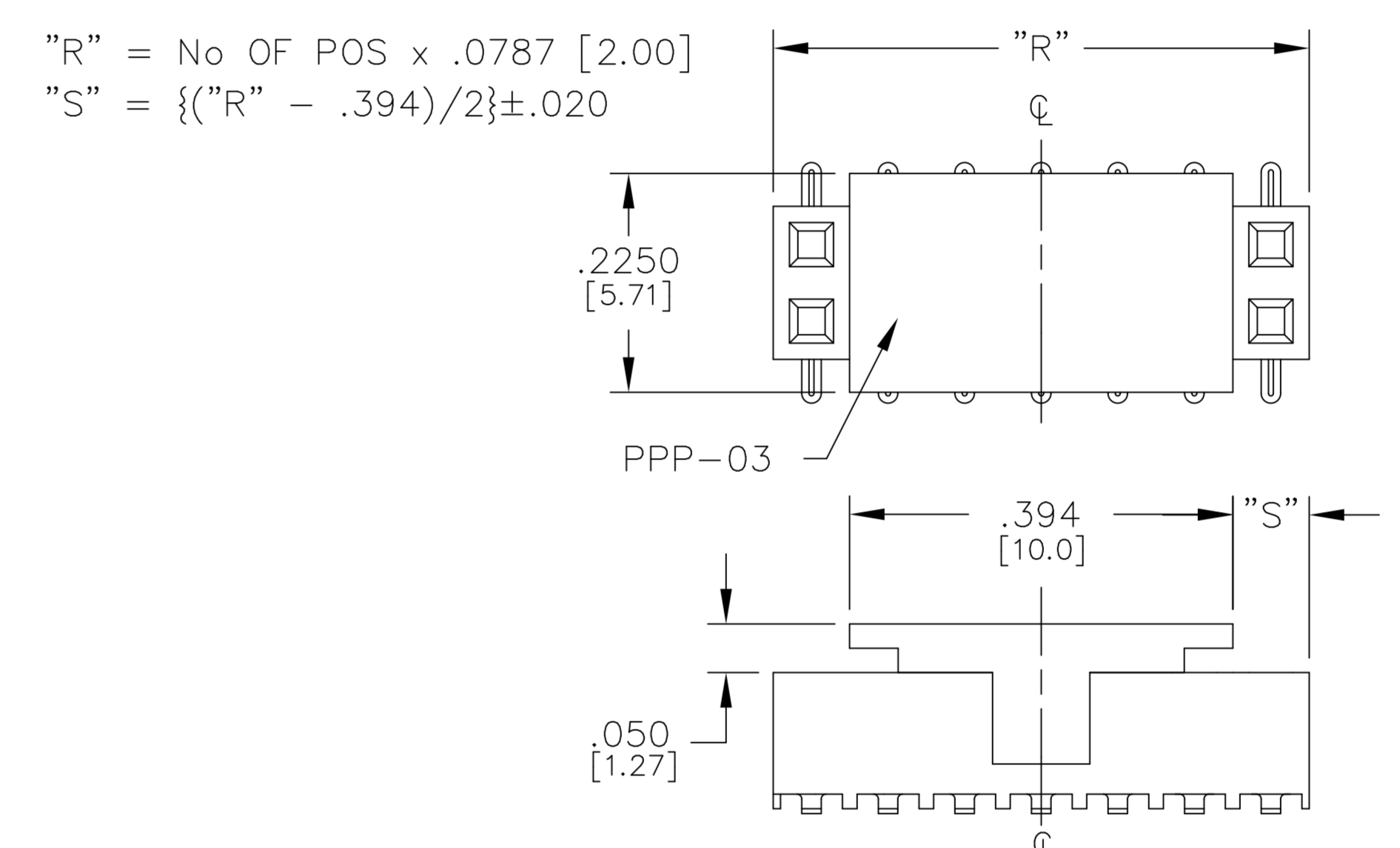

FIG. 3  
-P: PICK AND PLACE PAD  
(PLACE PPP-03 ABOUT C.L. AS SHOWN)  
(SEE NOTE 10)

FIG. 2  
-02: SURFACE MOUNT

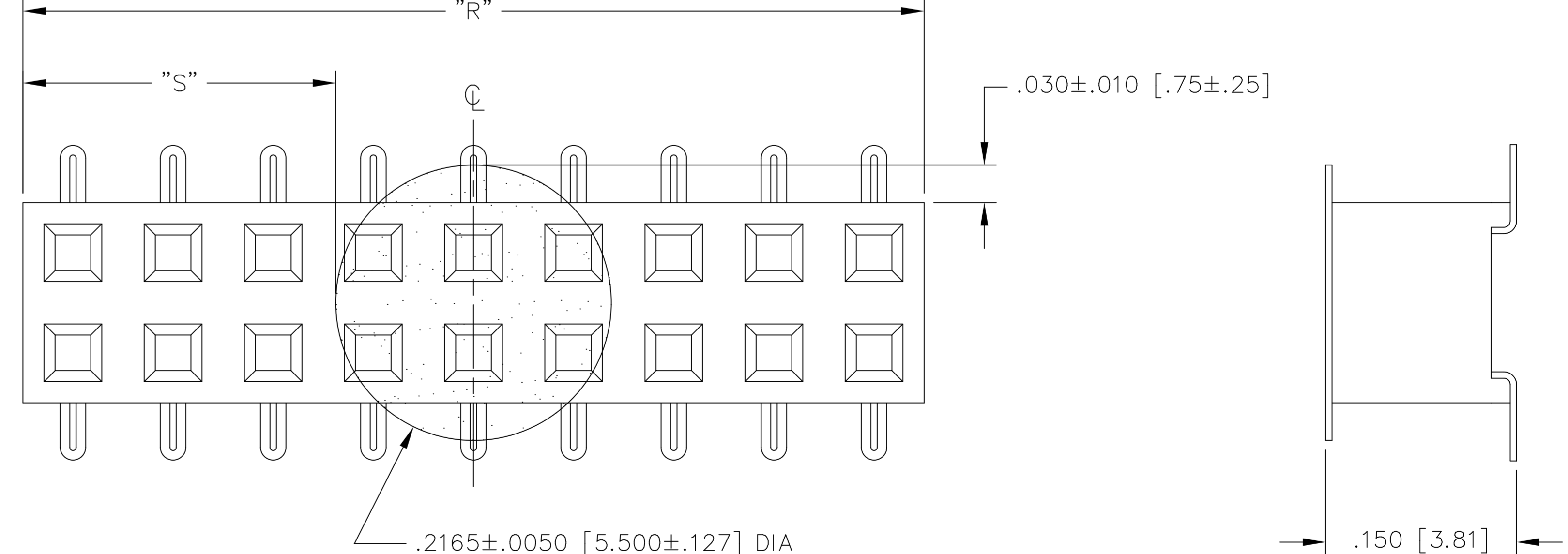
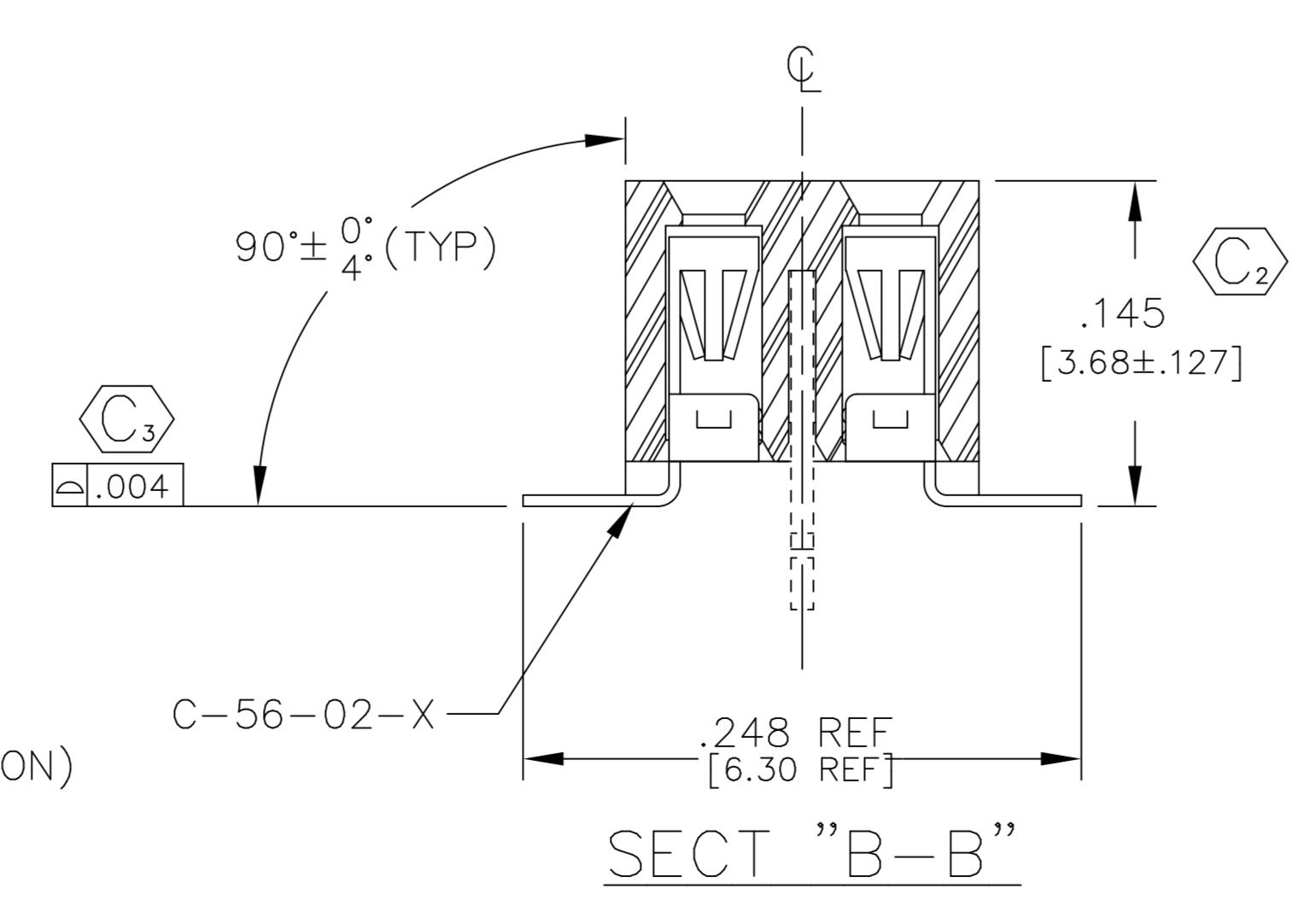
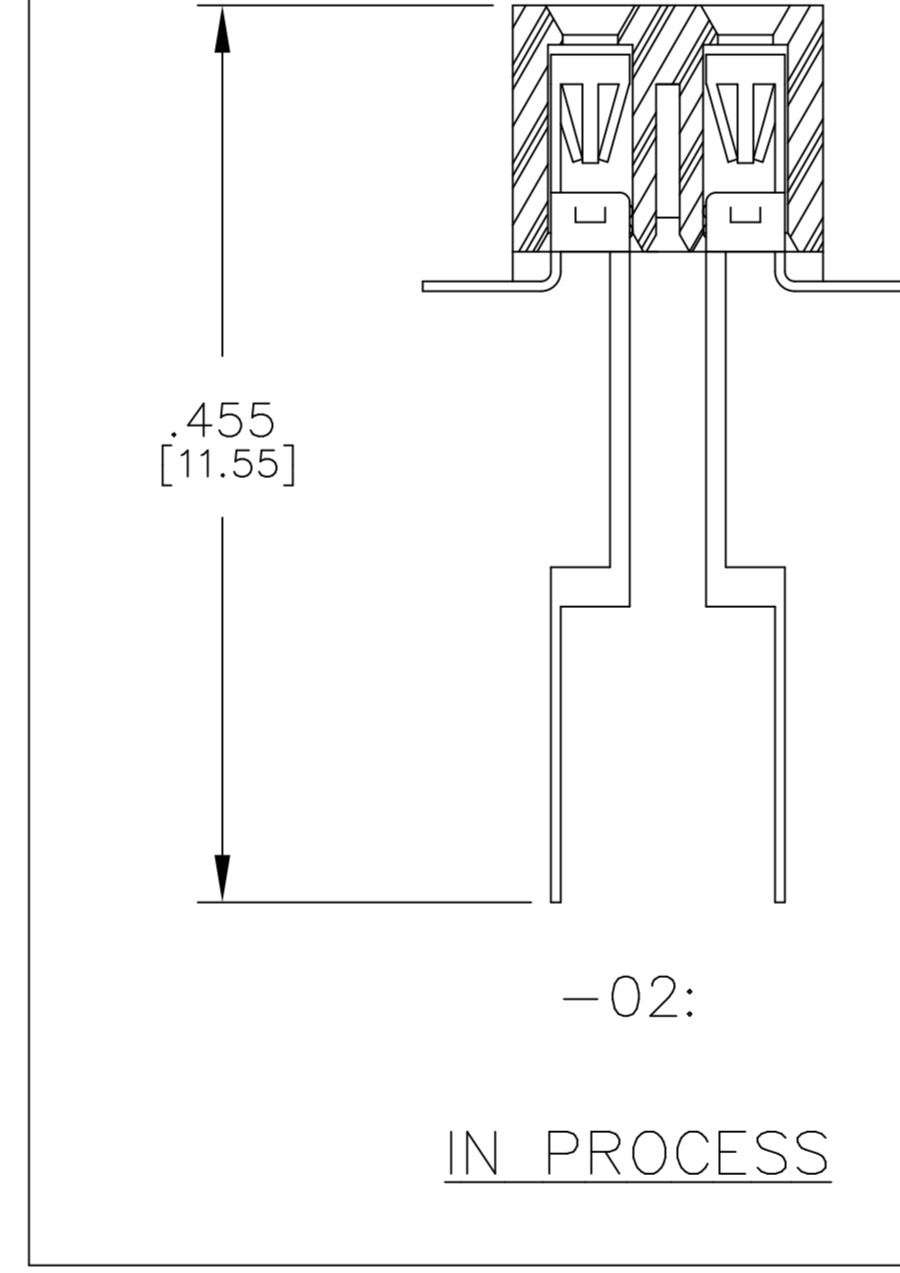
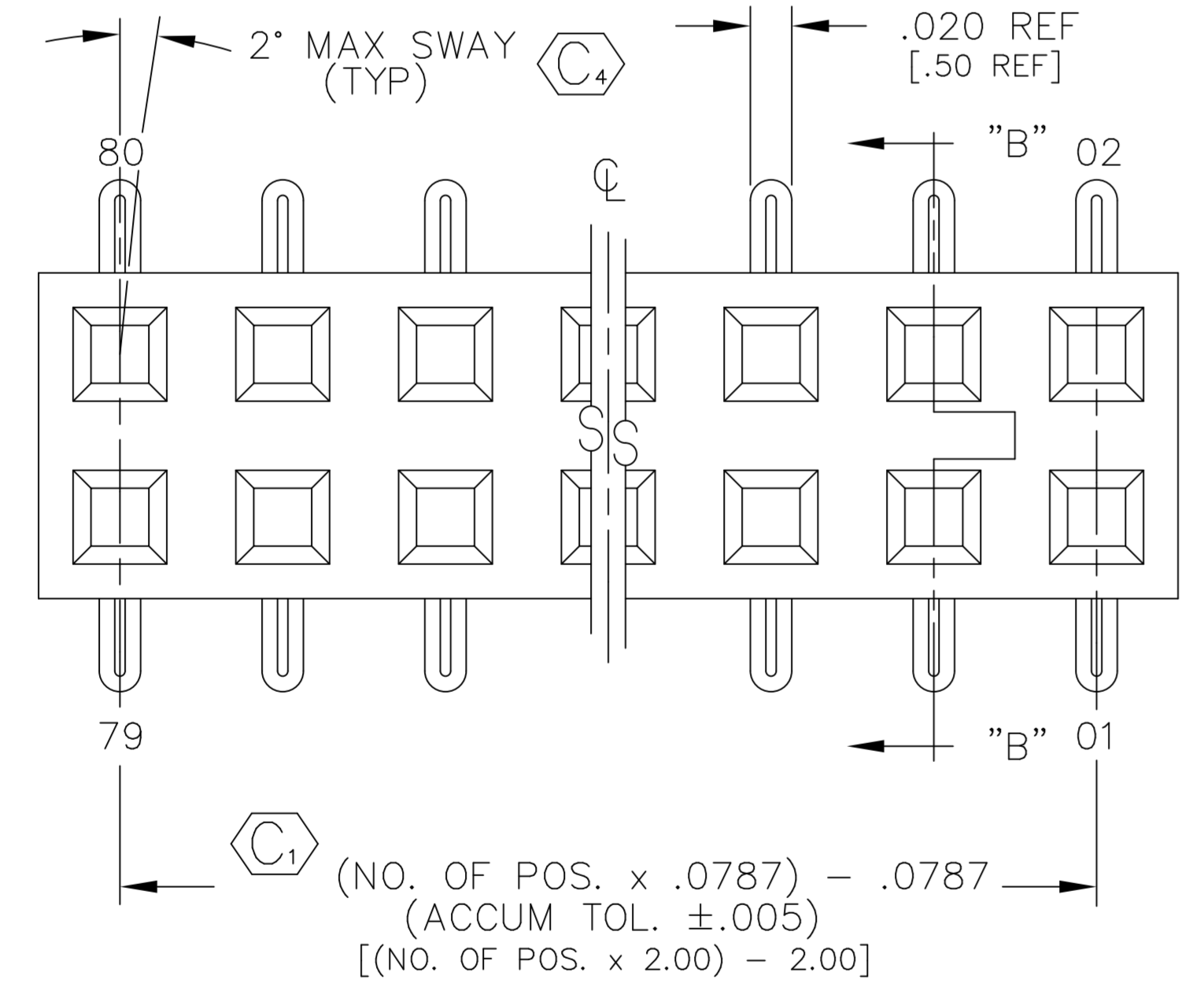

FIG. 4  
-K: POLYAMIDE FILM PAD  
[2 POSITION MINIMUM, SEE NOTE 10]

PROPRIETARY NOTE  
THIS DOCUMENT CONTAINS INFORMATION CONFIDENTIAL AND PROPRIETARY TO SAMTEC INC. AND SHALL NOT BE REPRODUCED OR TRANSMITTED TO OTHERS OR USED FOR ANY PURPOSE OTHER THAN THAT FOR WHICH IT WAS OBTAINED WITHOUT THE EXPRESSED WRITTEN CONSENT OF SAMTEC INC.

EXISPROD\ASSEMBLY\2MM  
SMM-1XX-XX-D-XX-X-XX-XX-ASM

**samtec**

520 PARK EAST BLVD. NEW ALBANY, INDIANA 47150  
PHONE (812) 944-6733 P.O. BOX 1147  
CODE 55322

MADE BY: KOLB 5-21-91 ENGINEER APPROVAL DEM

SMM-1XX-XX-D-XX-X-XX-XX-ASM  
SHEET 1 OF 2