

DO NOT SCALE FROM THIS PRINT

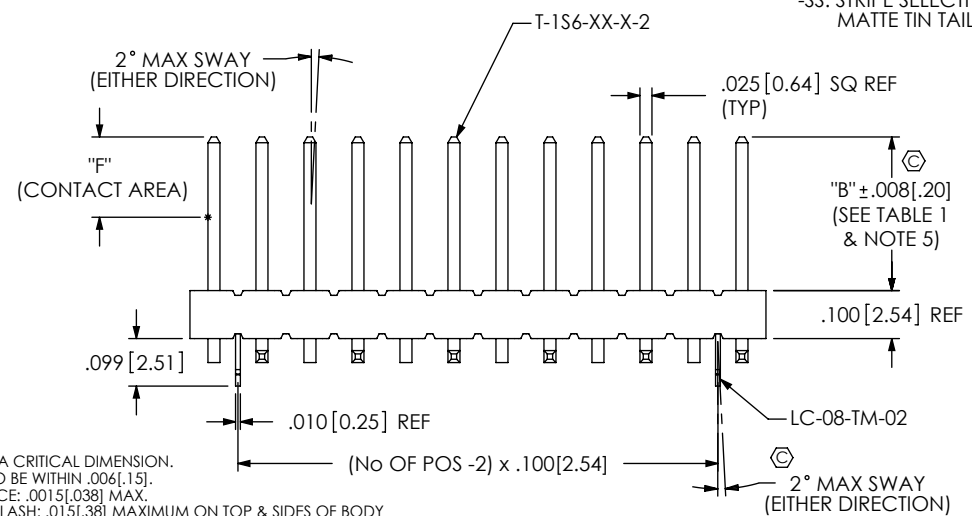
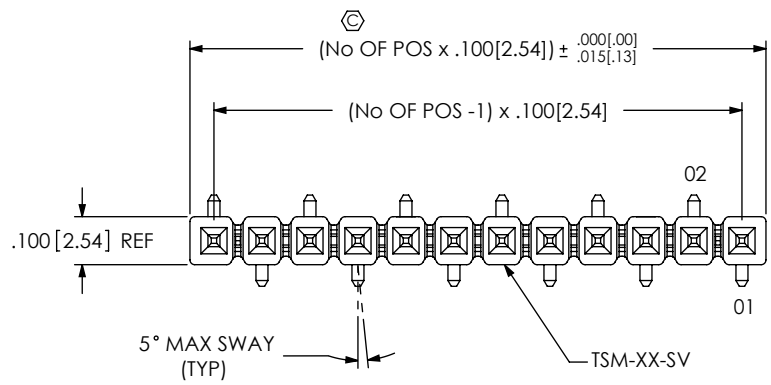
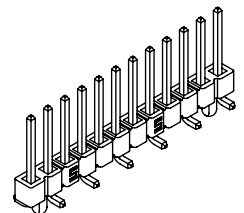

- NOTES:
1. $\text{\textcircled{C}}$ REPRESENTS A CRITICAL DIMENSION.
 2. COPLANARITY TO BE WITHIN .006[.15].
 3. BURR ALLOWANCE: .0015[.038] MAX.
 4. MAXIMUM CUT FLASH: .015[.38] MAXIMUM ON TOP & SIDES OF BODY AND .030[.76] MAXIMUM ON SURFACE MOUNT SIDE OF BODY.
 5. POST HEIGHT VARIATION BETWEEN ANY TWO PINS: .005[.13] MAXIMUM.
 6. MAXIMUM ALLOWABLE BOW: .002[.05] INCH/INCH AFTER ASSEMBLY.
 7. LEADS MAY NOT BE VISIBLE FOR CUSTOMER VISUAL INSPECTION WITH -P OPTION ON SMALLER POSITIONS PARTS.
 8. DUE TO THE HIGH AMOUNT OF INSERTION FORCE NEEDED, THE -LC OPTION IS NOT COMPATIBLE WITH AUTO PLACEMENT. SAMTEC RECOMMENDS MANUAL PLACEMENT FOR ALL ASSEMBLIES WITH THE -LC OPTION.
 9. -01 LEAD STYLE ONLY, MATES WITH SSW, SSQ, BCS, SSM, ESW, ESQ.

TABLE 1

STYLE	"B"	"C"	"D" MAX	"E"	"F"	TERMINAL
-01	.230[5.84]	.280[7.11]	.208[5.28]	.445[11.30]	.165 [4.19]	T-1S6-16-X-2
-02	.320[8.13]	.370[9.40]	.205[5.20]	.530[13.46]	.165 [4.19]	T-1S6-08-X-2
-03	.420[10.67]	.470[11.94]	.205[5.20]	.630[16.00]	.165 [4.19]	T-1S6-15-X-2
-04	.120[3.05]	.270[6.86]	.208[5.28]	.335[8.51]	.050 [1.27]	T-1S6-21-X-2
-05	.075[1.91]	.270[6.86]	.223[5.66]	.300[7.62]	.050 [1.27]	T-1S6-18-X-2

TSM-1XX-XX-XXX-SV-XX-XXX-XX

No OF POSITIONS
-02 THRU -50

LEAD STYLE
SEE TABLE 1

PLATING SPECIFICATION

OPTION #3
-P: PICK & PLACE PAD (SEE FIG. 3)
[USE PPP-07] (4 POS MINIMUM OR -02 & -03 POS WITH -TR) (SEE NOTE 7)
-TR: TAPE & REEL (SEE NOTE 7) (-02 THRU -22 POS)

OPTION #2
POLARIZED POSITION: SPECIFY PIN OMITTED

OPTION #1
-LC: LOCKING CLIP (SEE FIG. 1) (SEE NOTE 8)
[USE LC-08-TM-02] (-02 THRU -36 POS: 2 PER STRIP -02 POS: 1 PER STRIP)
-A: ALIGNMENT PIN (SEE FIG. 2)

ROW SPECIFICATION
-SV: SINGLE VERTICAL (USE TSM-XX-SV-XX)

- T: MATT TIN CONTACT AND TAIL
- S: SELECTIVE, 30 Au / 50 Ni MIN ON CONTACT, MATTE TIN TAIL
- G: GOLD, 10 Au / 50 Ni MIN ON CONTACT, 3 Au / 50 Ni MIN ON TAIL
- L: LIGHT SELECTIVE, 10 Au / 50 Ni MIN ON CONTACT, MATTE TIN ON TAIL
- F: FLASH SELECTIVE, 3 Au / 50 Ni MIN ON CONTACT, MATTE TIN TAIL
- H: HEAVY GOLD, 30 Au / 50 Ni MIN ON CONTACT, 3 Au / 50 Ni MIN ON TAIL
- TL: TIN / LEAD (90/10+/-5%) CONTACT AND TAIL [LEAD STYLE -01 & -02 ONLY]
- STL: SELECTIVE, 30 Au / 50 Ni MIN ON CONTACT, TIN/LEAD (90/10+/-5%) TAIL [LEAD STYLE -01 & -02 ONLY]
- TM: MATTE TIN CONTACT AND TAIL
- SM: SELECTIVE, 30 Au / 50 Ni MIN ON CONTACT, MATTE TIN TAIL
- LM: LIGHT SELECTIVE, 10 Au / 50 Ni MIN ON CONTACT, MATTE TIN TAIL
- FM: FLASH SELECTIVE, 3 Au / 50 Ni MIN ON CONTACT, MATTE TIN TAIL
- SS: STRIPE SELECTIVE, 30 Au / 50 Ni MIN ON CONTACT, MATTE TIN TAIL (SEE NOTE 9)

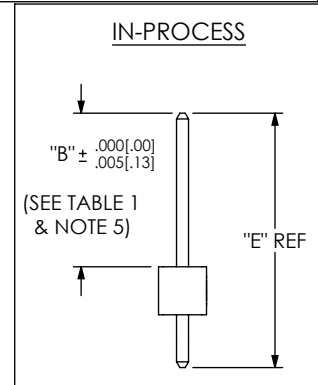
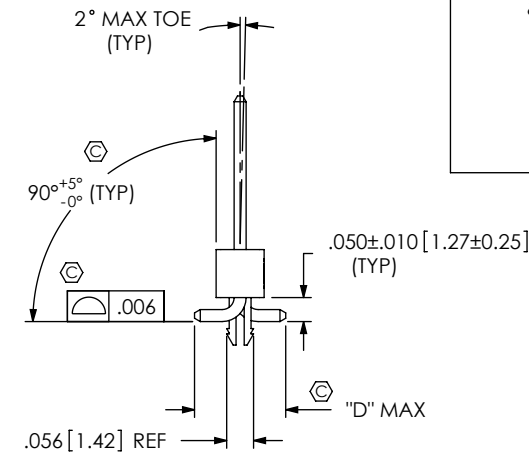
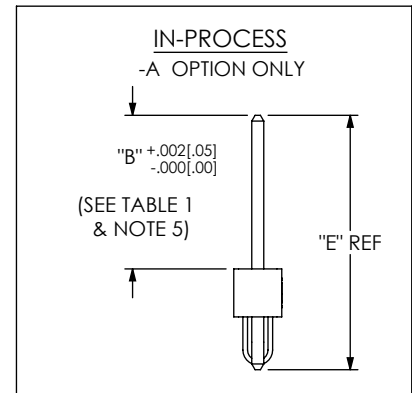

FIG 1
TSM-112-02-XXX-SV-LC SHOWN

UNLESS OTHERWISE SPECIFIED, DIMENSIONS ARE IN INCHES.

TOLERANCES ARE:

DECIMALS	ANGLES
.XX: ±.01 [.3]	2°
.XXX: ±.005 [.13]	
.XXXX: ±.0020 [.051]	

PROPRIETARY NOTE

THIS DOCUMENT CONTAINS INFORMATION CONFIDENTIAL AND PROPRIETARY TO SAMTEC, INC. AND SHALL NOT BE REPRODUCED OR TRANSFERRED TO OTHER DOCUMENTS OR DISCLOSED TO OTHERS OR USED FOR ANY PURPOSE OTHER THAN THAT WHICH IT WAS OBTAINED WITHOUT THE EXPRESSED WRITTEN CONSENT OF SAMTEC, INC.



520 PARK EAST BLVD, NEW ALBANY, IN 47150
PHONE: 812-944-6733 FAX: 812-948-5047
e-Mail: info@SAMTEC.com code 55322

MATERIAL: DO NOT SCALE DRAWING SHEET SCALE: 2.5:1

INSULATOR:
LCP, UL 94 VO
COLOR: BLACK

TERMINAL: PHOS BRONZE

F:\DWG\MISC\MKTG\TSM-1XX-XX-XXX-SV-XX-XXX-XX-MKT.SLDDRW

DESCRIPTION: SINGLE ROW .100 SMT ASSEMBLY

DWG. NO. TSM-1XX-XX-XXX-SV-XX-XXX-XX

BY: DEAN P 8/21/2002 SHEET 1 OF 2

FIG 3

-P: PICK & PLACE PAD OPTION
4 POSITION MINIMUM
[PLACE PAD ON CENTERLINE AS SHOWN]

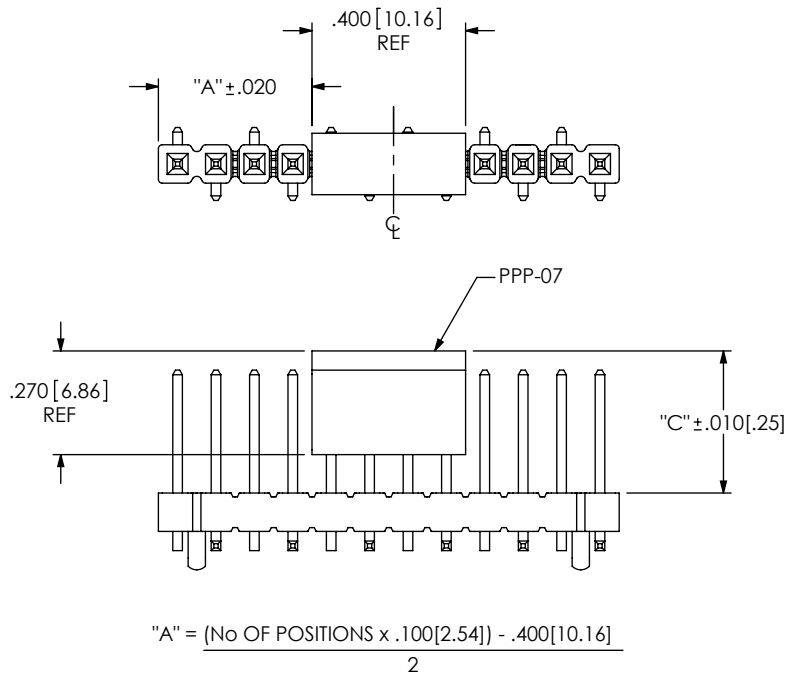

FIG 2

-A: ALIGNMENT PIN OPTION
TSM-112-02-X-SV-A SHOWN
[DIFFERENT AS SHOWN, OTHERWISE SAME AS FIG 1]

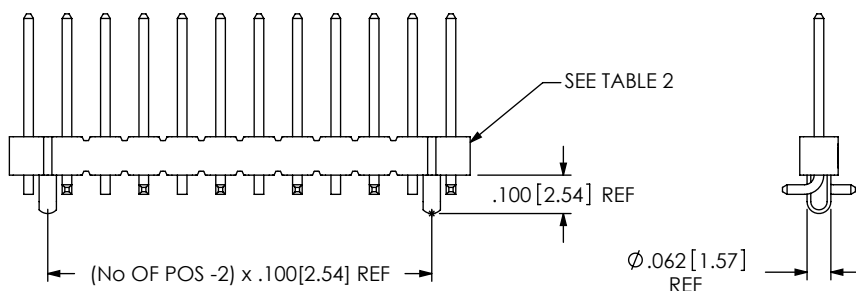

TABLE 2: ALIGNMENT PIN BODY	
POSITION	USE BODY
-3	TSM-03-SV-A
-02 & -04 THRU -50	TSM-XX-SV-X

PACKAGING TABLE

STYLE	OPTION	TUBE	PLUG
-01	----	PT-1-24-02-29 (SEE NOTE 3)	TP-24
-02, -04, -05	----	PT-1-24-02-29 (SEE NOTE 3)	TP-24
-01, -02, -04, -05	-LC, -A	PT-1-24-02-29 (SEE NOTE 3)	TP-24
-01, -04, -05	-P	PT-1-24-05-29	TP-03
-01, -04, -05	-LC-P, -A-P	PT-1-24-05-29	TP-03
-02	-P	PT-1-24-13-29	TP-03
-02	-LC-P, -A-P	PT-1-24-13-29	TP-03
-03	----	PT-1-24-10-29 (SEE NOTE 3)	TP-24
-03	-LC, -A	PT-1-24-10-29 (SEE NOTE 3)	TP-24
-03	-P	PT-1-24-14-29	TP-09
-03	-LC-P, -A-P	PT-1-24-14-29	TP-09

NOTES:

1. LOAD PARTS POSITION 1 FIRST IN SAME DIRECTION AS ARROW.
2. NOTE DELETED
3. PACKAGE POSITIONS -04 THRU -36.
4. POLARIZED 4 POSITION PARTS WITHOUT PADS ARE TO BE LAYER PACKAGED OR PACKAGED IN TAPE AND REEL.

FIG 4
TUBE PACKAGING

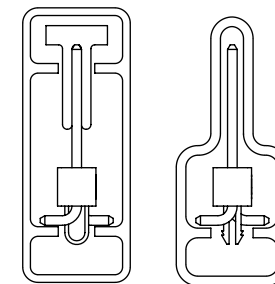
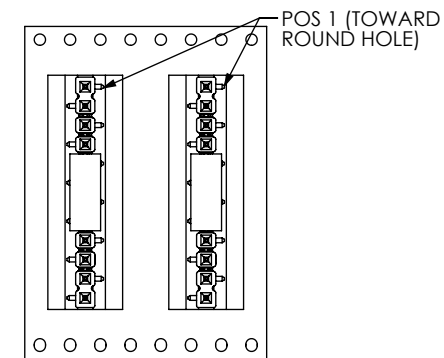

FIG 5

-TR: TAPE & REEL PACKAGNG OPTION



F:\DWG\MISC\MKTG\TSM-1XX-XX-XXX-SV-XX-XXX-XX-MKT.SLDRW

PROPRIETARY NOTE

THIS DOCUMENT CONTAINS INFORMATION CONFIDENTIAL AND PROPRIETARY TO SAMTEC, INC. AND SHALL NOT BE REPRODUCED OR TRANSFERRED TO OTHER DOCUMENTS OR DISCLOSED TO OTHERS OR USED FOR ANY PURPOSE OTHER THAN THAT WHICH IT WAS OBTAINED WITHOUT THE EXPRESSED WRITTEN CONSENT OF SAMTEC, INC.

DO NOT SCALE DRAWING

SHEET SCALE: 2:1

samtec

520 PARK EAST BLVD, NEW ALBANY, IN 47150
PHONE: 812-944-6733 FAX: 812-948-5047
e-Mail: info@SAMTEC.com code 55322

DESCRIPTION: SINGLE ROW .100 SMT ASSEMBLY

DWG. NO. TSM-1XX-XX-XXX-SV-XX-XXX-XX

BY: DEAN P 8/21/2002 SHEET 2 OF 2