

# SERPAC 113Ri (3D exploded)

Electronic Enclosures

- Click on image to show toolbar. Use ▶ || to Play/Pause Animation.
- Left click and drag on image to move 3D model.

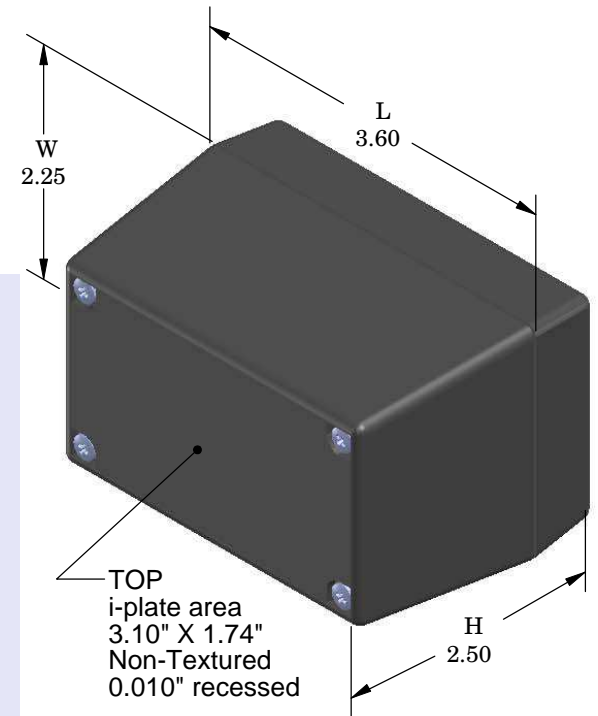
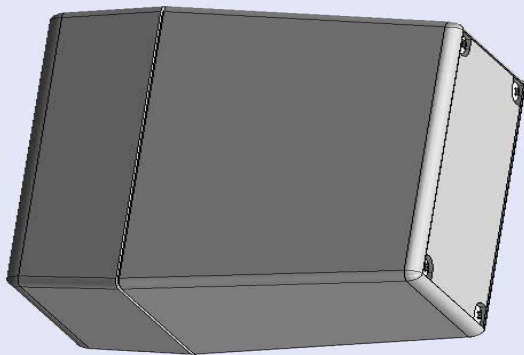

Threaded inserts only have to be assembled the first time.

Waterproofing gasket  
PS11 optional  
see note #2

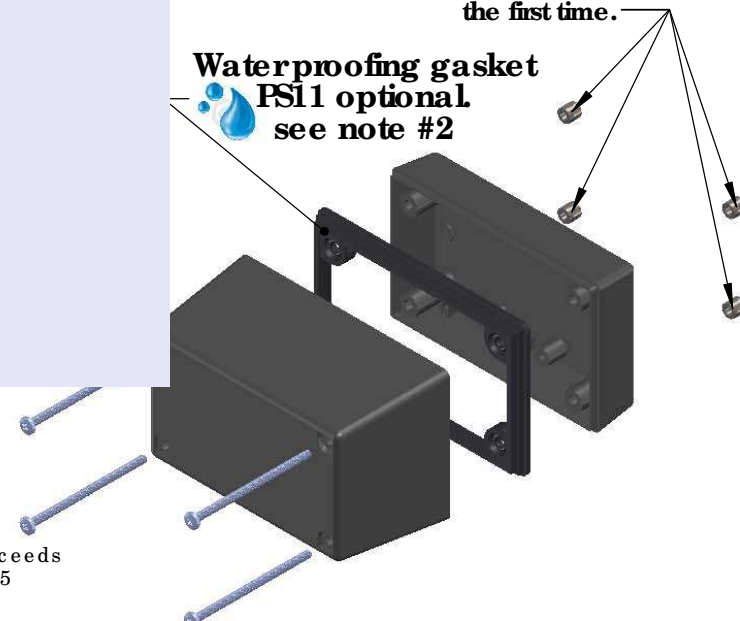

- a) Zoom in & out with center wheel.
- b) Pause at any moment to view and or print views.
- c) Change the views to ortho and section views if needed from the Views pull down menu.
- d) Explore options included in the tool bar like: Views, Transparency of model, Lighting type, etc.

PART NO.	DESCRIPTION (Included)	ACCESSORIES (Optional)	
PART NO.	DESCRIPTION	PART NO.	DESCRIPTION
1-3Ri	TOP		
11	BOTTOM	50	Non-skid Feet
6019	4-40 SCREW (4)	PS11	Perimeter Seal
6102	THREADED INSERTS (4)	310	Prototype grid board
		410	Prototype clad board

Notes: Enclosure weight .18 lbs/ 84 gm  
 1) Enclosure meets or exceeds IP40 and NEMA 1  
 2) When used with PS11 the enclosure meets or exceeds IP 67 and NEMA 4X, 12 and 13 MIL-STD-810G 506.5  
 3) Circuit Board drawings can be download at:  
 Top: [http://www.serpac.com/Accessories/CircuitBoard/drawings/X13\\_CB.pdf](http://www.serpac.com/Accessories/CircuitBoard/drawings/X13_CB.pdf)  
 Bottom: <http://www.serpac.com/Accessories/CircuitBoard/drawings/310-410.pdf>  
 4) All components are RoHS Compliant.

ALL DIMENSIONS ARE ±.010" 7/27/10 (1 of 2)  
 2009 Wright Ave. La Verne, CA 91750  
 Ph. (626) 331-0517 Ex. (626) 331-8584 serpac.com

# SERPAC 113Ri (user print)

Electronic Enclosures

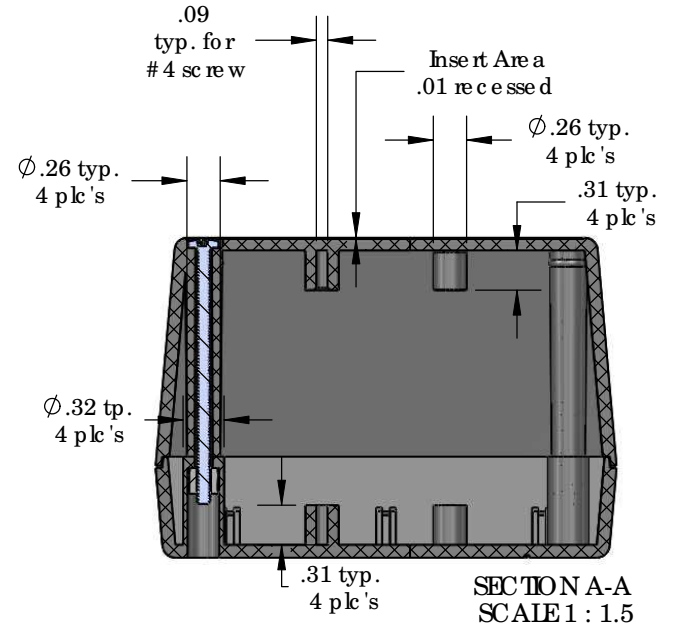
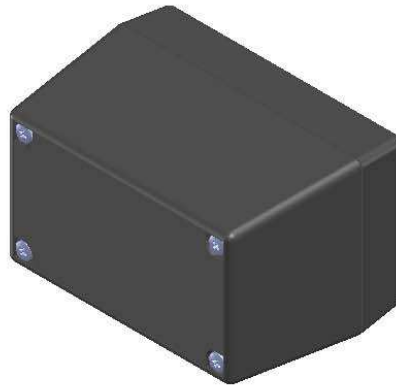
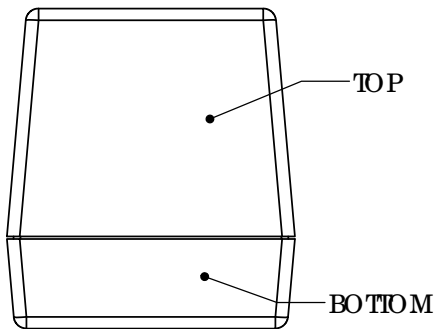
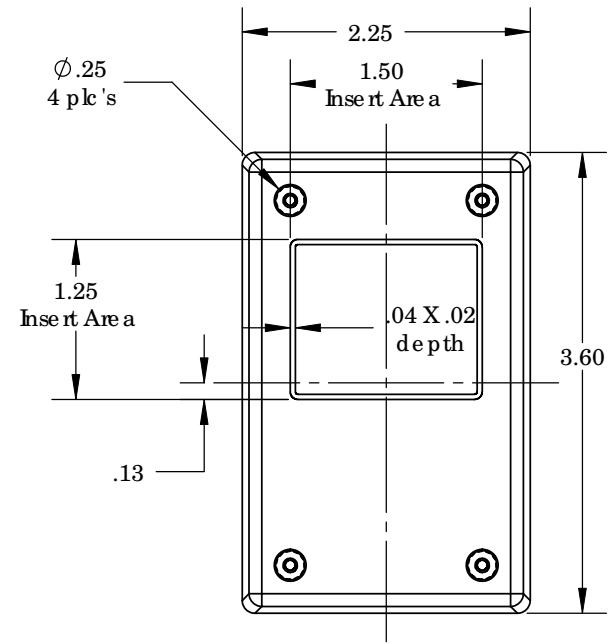
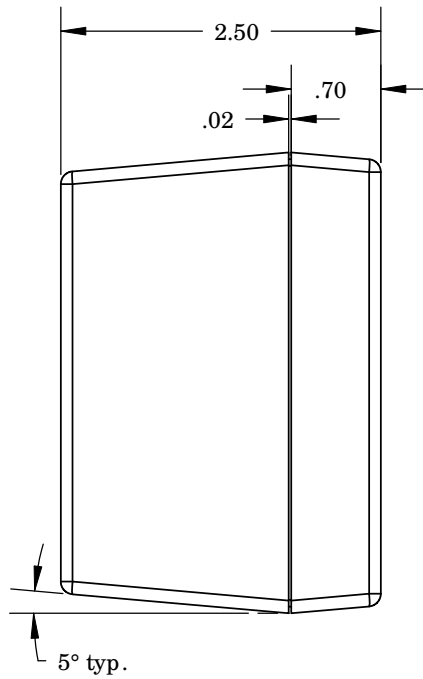
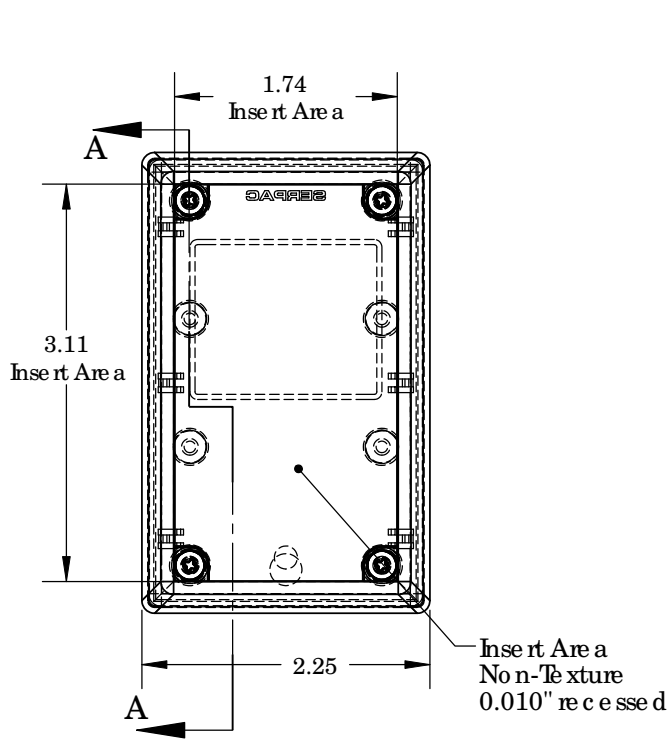

Notes: Enclosure weight .18 lbs / 84 gm  
 1) Enclosure meets or exceeds IP40 and NEMA 1  
 2) When used with PS11 the enclosure meets or exceeds IP 67 and NEMA 4X, 12 and 13 MIL-SID-810G 506.5  
 3) Circuit Board drawings can be downloaded at:

Top: [http://www.serpac.com/Accessories/CircuitBoard/drawings/X13\\_CB.pdf](http://www.serpac.com/Accessories/CircuitBoard/drawings/X13_CB.pdf)  
 Bottom: <http://www.serpac.com/Accessories/CircuitBoard/drawings/310-410.pdf>

4) All components are RoHS Compliant.

PART NO.	DESCRIPTION (Included)	ACCESSORIES (Optional)	
1-3Ri	TOP	PART NO.	DESCRIPTION
11	BOTTOM	50	Non-skid Feet
6019	4-40 SCREW (4)	PS11	Perimeter Seal
6102	THREADED INSERTS (4)	310	Prototype grid board
		410	Prototype clad board

ALL DIMENSIONS ARE ± .010" 7/27/10 (2 of 2)  
 2009 Wright Ave. La Verne, CA 91750  
 Ph. (626) 331-0517 Ex. (626) 331-8584 [www.serpac.com](http://www.serpac.com)