

# SERPAC A41

Electronic Enclosures

**NOTES:**

1) When machine or I-plates modifications are required, use the center of the enclosure to dimension.

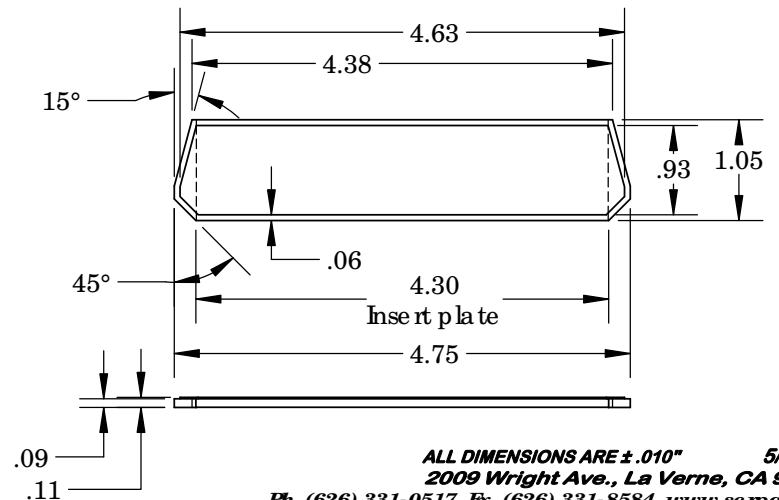
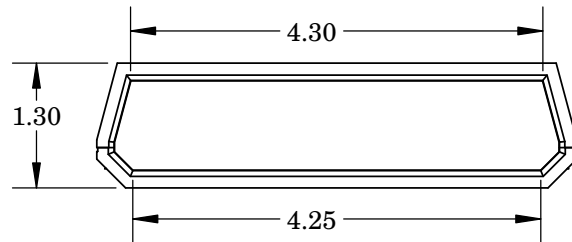
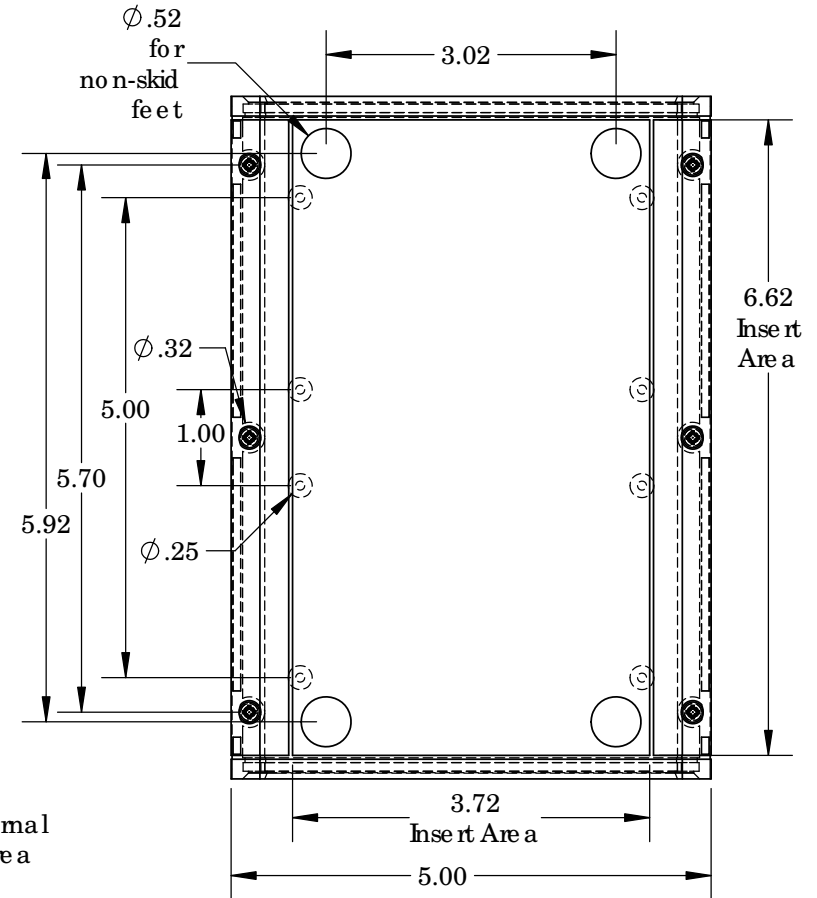
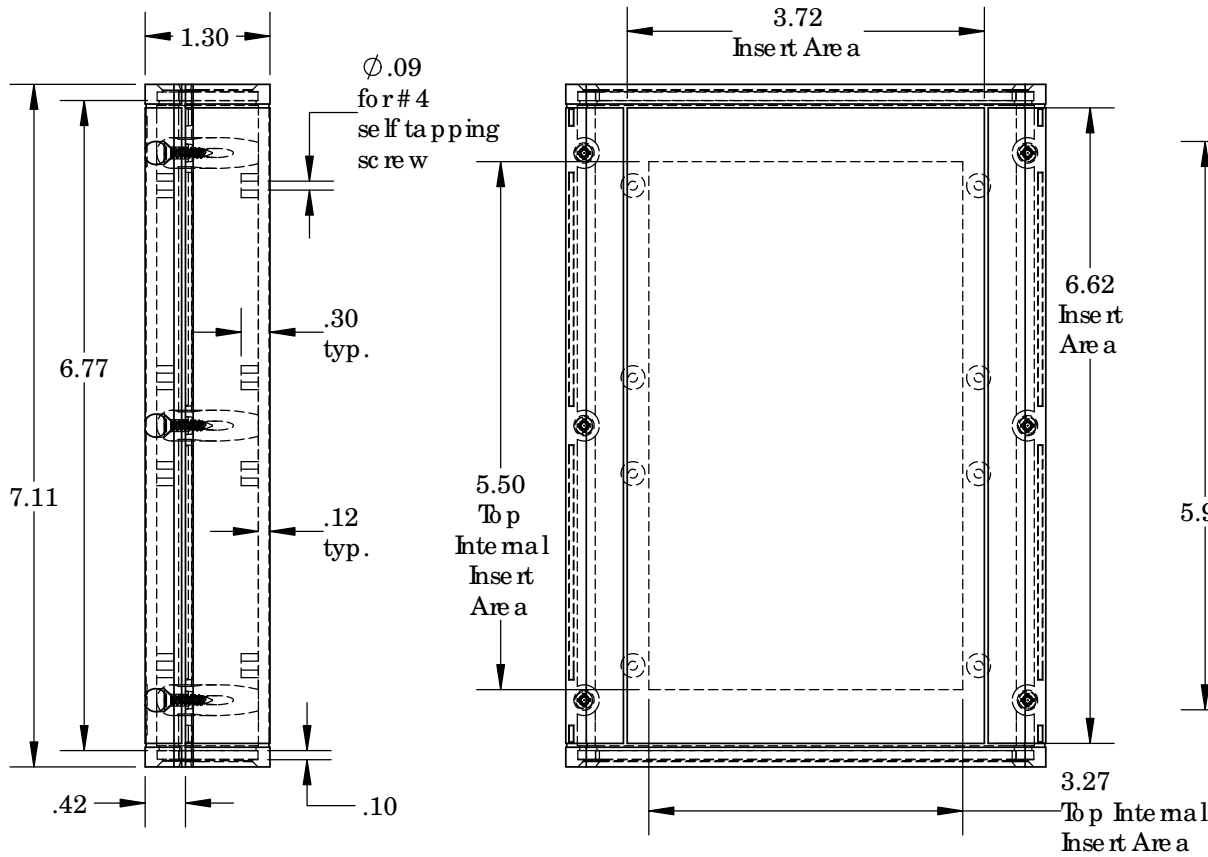

PART NO.	DESCRIPTION	ACCESSORIES	
2018	A41 TOP	PART NO.	DESCRIPTION
2019	A41 BOTTOM	51	NON SKID FEET
2020	A41 END PANEL	2020IR	A41 INFRARED PANEL
6006	SCREW 4x3/4" PHILFLAT (4)	2020CL	A41 CLEAR PANEL
		2020DB9	DB9 CUT OUT PANEL
		2020DB25	DB25 CUT OUT PANEL

ALL DIMENSIONS ARE ± .010" 5/22/13  
2009 Wright Ave., La Verne, CA 91750

Ph. (626) 331-0517 Ex. (626) 331-8584 www.serpac.com