

SERPAC A42

Electronic Enclosures

NOTES:

1) When machine or I-plates modifications are required, use the center of the enclosure to dimension.

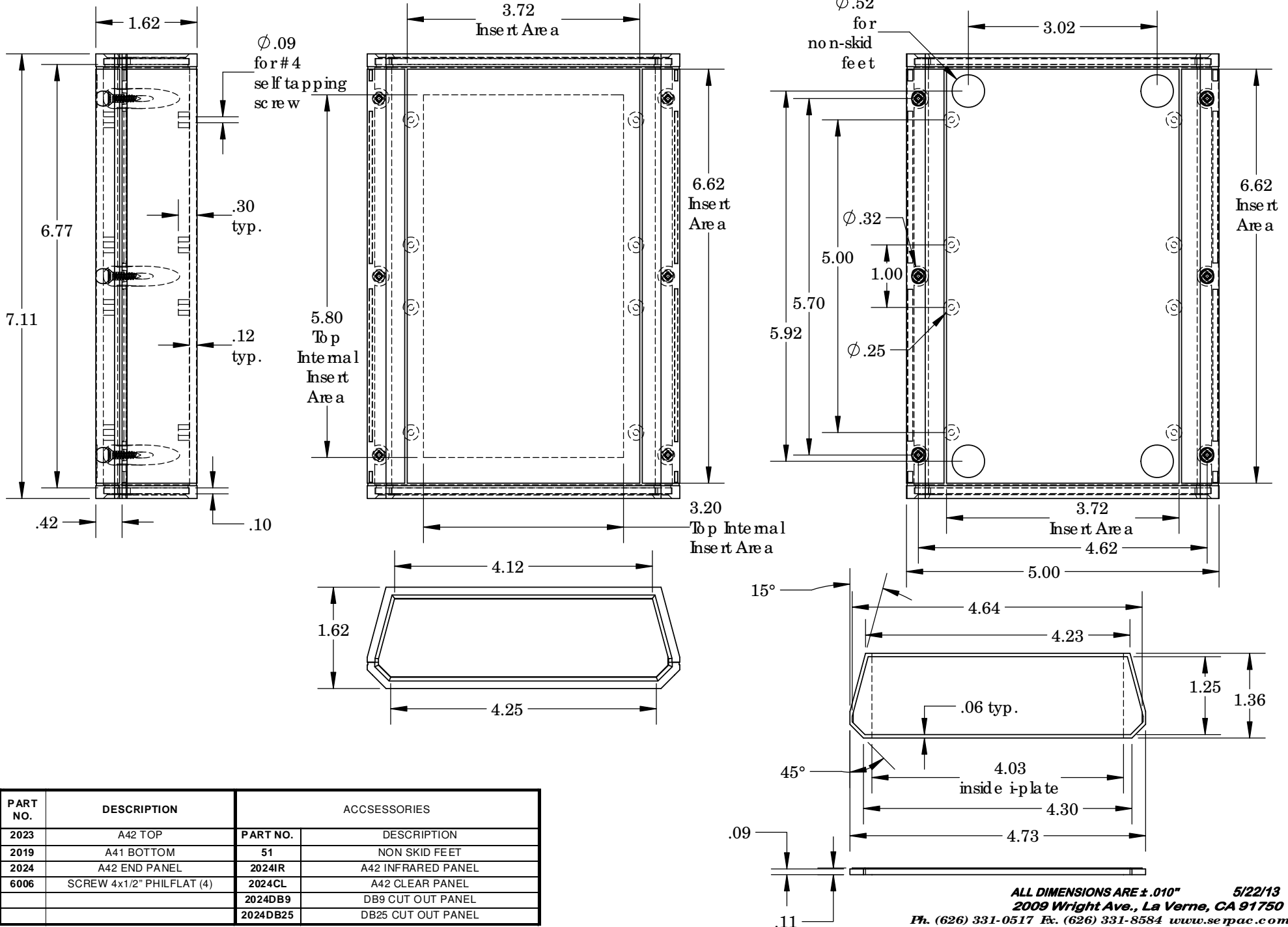

PART NO.	DESCRIPTION	ACCESSORIES	
2023	A42 TOP	PART NO.	DESCRIPTION
2019	A41 BOTTOM	51	NON SKID FEET
2024	A42 END PANEL	2024IR	A42 INFRARED PANEL
6006	SCREW 4x1/2" PHILFLAT (4)	2024CL	A42 CLEAR PANEL
		2024DB9	DB9 CUT OUT PANEL
		2024DB25	DB25 CUT OUT PANEL