

**FG-26651-C36**

**SHT 1.1**

NOTES:

- INCREASED PRESSURE AT THE SOUND INLET CAUSES A POSITIVE GOING VOLTAGE TO APPEAR AT THE OUTPUT TERMINAL, RELATIVE TO THE NEGATIVE TERMINAL.

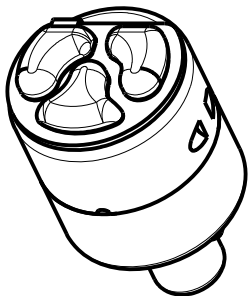
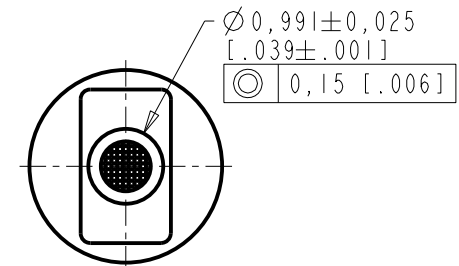
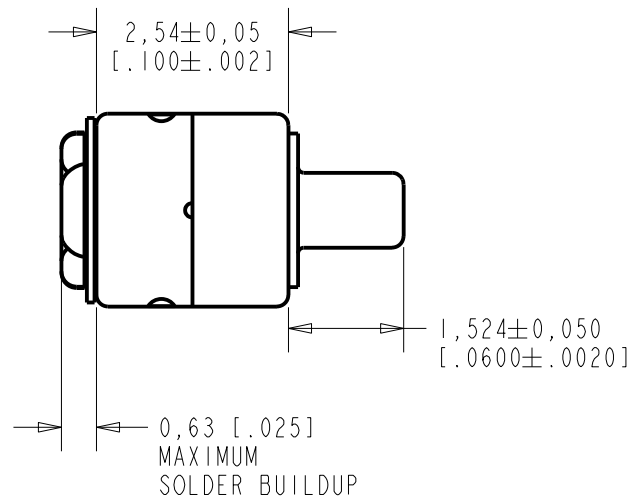
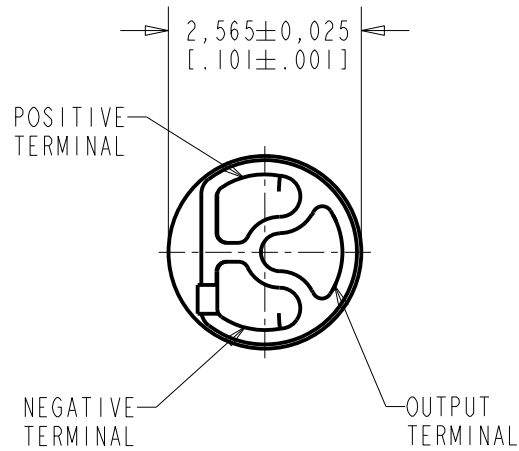

DIMENSIONS IN MILLIMETERS [INCHES]

Revision	C.O. #	Implementation Date	RELEASE LEVEL	REVISION
G	MI0104799	8-29-12	Active	G

SCALE: 10:1		DR. BY	DATE
DO NOT SCALE DRAWING		MMM	1-20-06
TITLE: MICROPHONE		CK. BY	DATE
OUTLINE DRAWING		GJP	1-25-06
FC-26651-C36		APP. BY	DATE
SHT 1.1		GJP	1-25-06

**KNOWLES ELECTRONICS**  
ITASCA, ILLINOIS U.S.A.

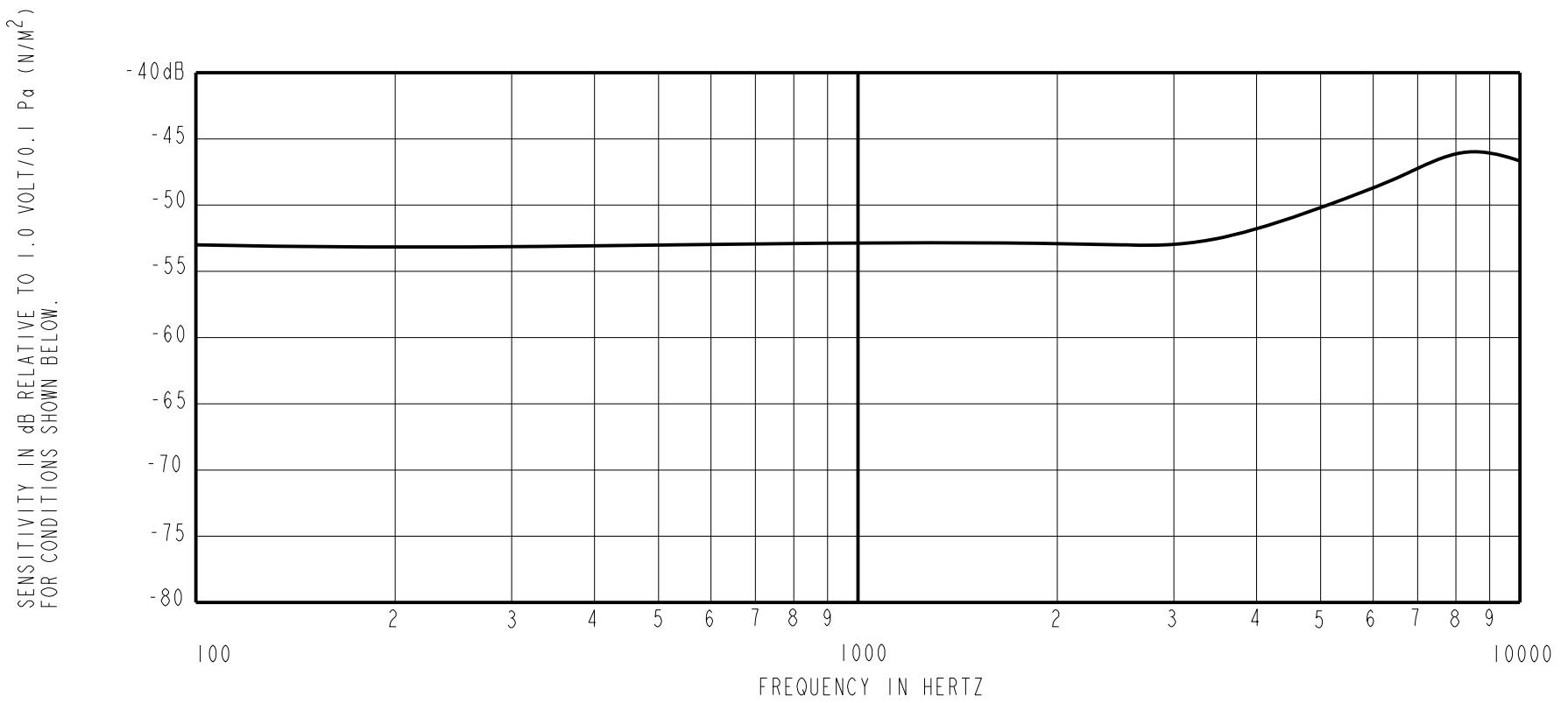

FREQUENCY	SENSITIVITY			DEVICE CONFORMITY	
	MIN.	NOM.	MAX.	RANGE OF DEVIATION FROM 1KHz	
100	---	-53.0	---	-3.0	+3.0
1000	-56.0	-53.0	-50.0	0.0	0.0
8500-11500	---	-46.0	---	+4.0	+10.0

- NOTES: 1. CASE CONNECTED TO NEGATIVE TERMINAL.  
 2. MICROPHONE TO BE FUNCTIONAL WITH 1.6 VDC SUPPLY.  
 3. TYPICAL SENSITIVITY TO HUMIDITY AT 1000Hz IS 0.06 dB/%RH  
 4. SENSITIVITY AND NOISE VALUES INDICATED ON THIS SPECIFICATION ARE VALID AT 50% HUMIDITY.

PORT LOCATION	DC SUPPLY	AMPLIFIER CURRENT DRAIN	SENSITIVITY CHANGE ON REDUCING SUPPLY TO 0.9VDC	"A" WEIGHTED NOISE (1 kHz EQUIV. SPL)	OUTPUT IMPEDANCE OHMS		
					MIN.	NOM.	MAX.
12S	1.3V	50 $\mu$ A MAX.	3 dB MAX.	28.0 dB MAX.	2800	4400	6800

Revision	C.O. #	Implementation Date	RELEASE LEVEL	REVISION
G	MI0104799	8-29-12	Active	G

WHEN TEST LIMITS ARE USED TO ESTABLISH INCOMING INSPECTION ACCEPTANCE/REJECTION CRITERIA, CORRELATION OF TEST EQUIPMENT WITH KNOWLES IS ALSO REQUIRED FOR ELIMINATION OF EQUIPMENT AND TEST METHOD VARIATION		DR. BY	DATE
TITLE: <b>MICROPHONE</b> PERFORMANCE SPECIFICATION		MMM	1-20-06
		GJP	1-25-06
<b>FG-26651-C36</b> SHT 2.1		APP. BY	DATE
		GJP	1-25-06

**KNOWLES ELECTRONICS**  
ITASCA, ILLINOIS U.S.A.