

TP-24605-000

SHT 1.1

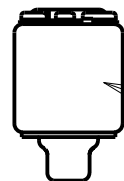
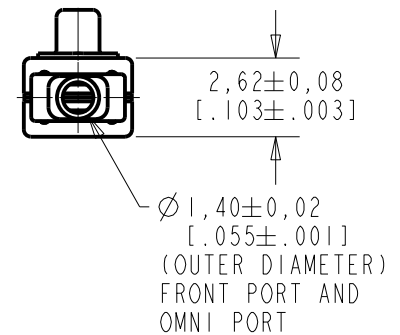
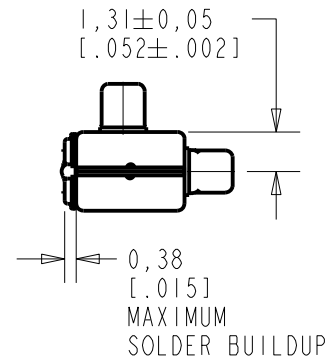
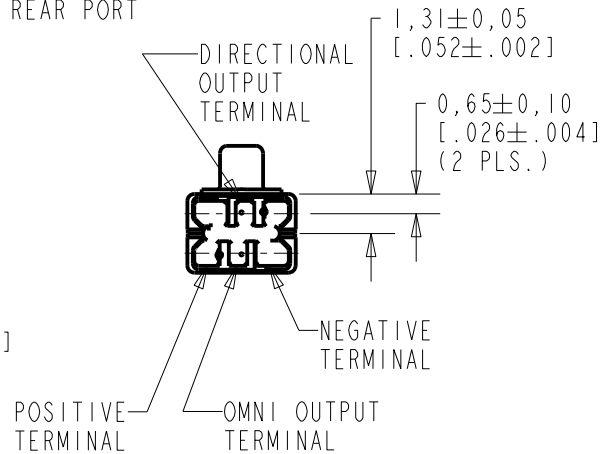
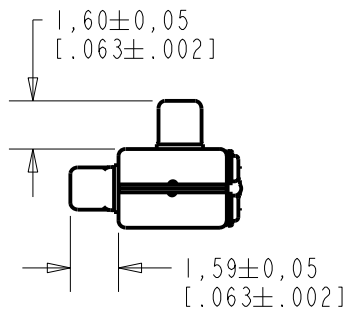
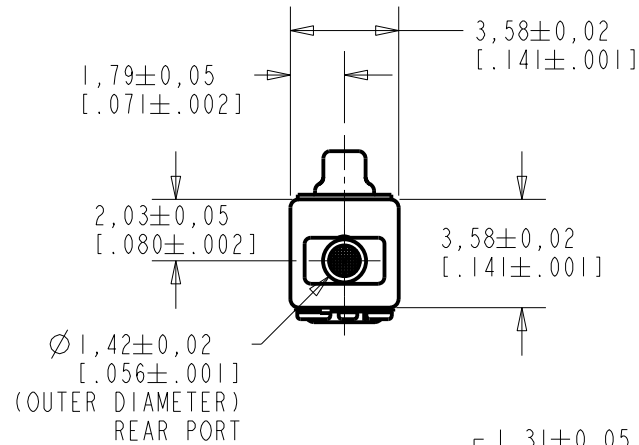

LASER MARK ON THIS SURFACE

NOMINAL WEIGHT
.126 GRAMS

DIMENSIONS IN MILLIMETERS [INCHES]

Revision	C.O. #	Implementation Date	RELEASE LEVEL	REVISION
E	MI0103591	5-11-10	Active	E
D	MI0102980	7-30-09		

SCALE: 4:1		DR. BY: DATE
DO NOT SCALE DRAWING		MMM 2-13-06
TITLE: MICROPHONE		CK. BY: DATE
OUTLINE DRAWING		GJP 2-15-06
TP-24605-000		APP. BY: DATE
SHT 1.1		GJP 2-15-06

KNOWLES ELECTRONICS
ITASCA, ILLINOIS U.S.A.

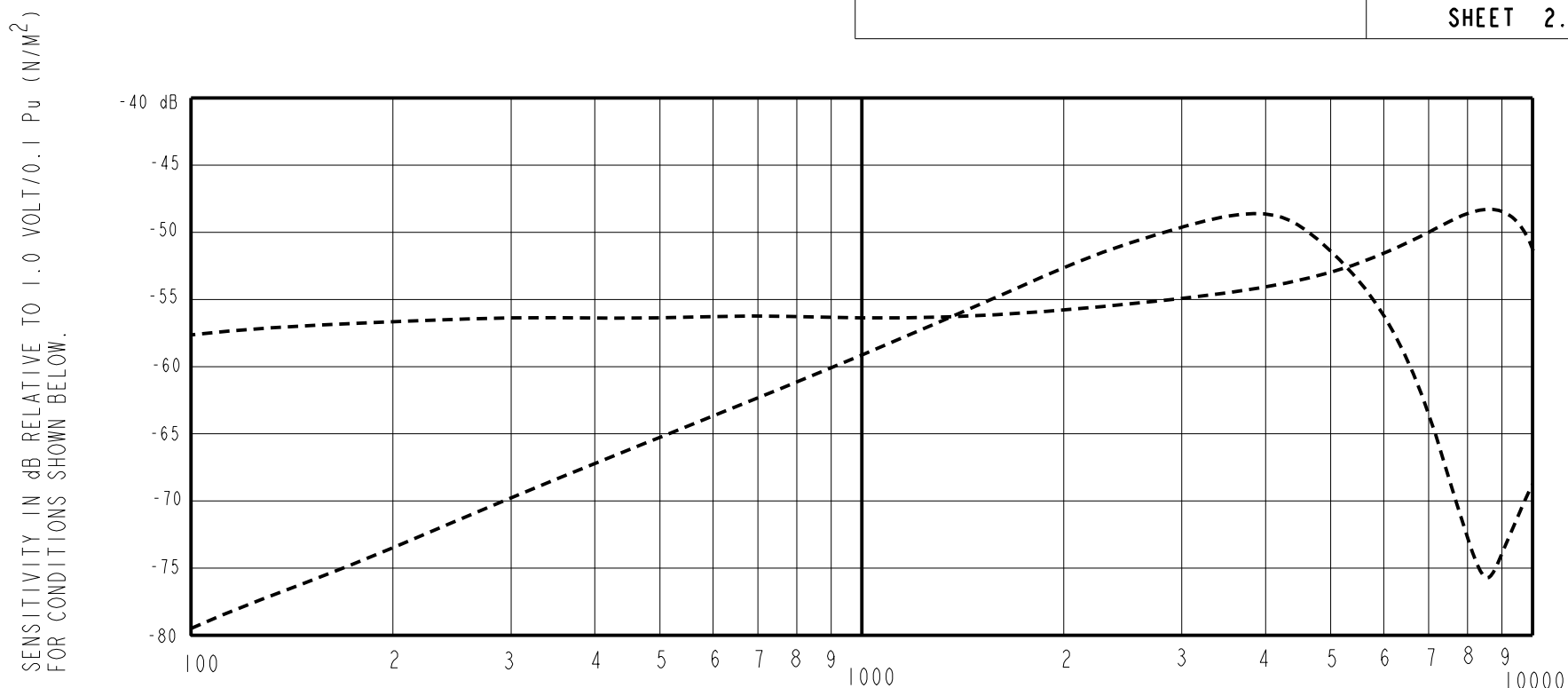

RANGE OF DEVIATION FROM 1 KHz

OMNI	100	---	-58.5	---	-5.0	0.0
DIRECTIONAL	1000	-59.5	-56.5	-53.5	0.0	0.0
	~8500	---	-49.0	---	4.0	+10.0

SENSITIVITY AT 1 KHz DIRECTIONAL re OMNIDIRECTIONAL -0.5 dB -4.5 dB

DIRECTIONAL	300	---	-69.0	---	-13.5	-7.5
0° ON AXIS	1000	-62.0	-59.0	-56.0	0.0	0.0
	~4000	---	-48.5	---	+7.5	+13.5

INTERNAL DELAY 8.0uS 11.0uS 14.0uS

- NOTES:
- CASE CONNECTED TO NEGATIVE TERMINAL.
 - MICROPHONE TO BE FUNCTIONAL WITH 1.6 VDC SUPPLY.
 - TYPICAL SENSITIVITY TO HUMIDITY AT 1000Hz IS 0.03 dB/%RH (OMNI), 0.07 dB/%RH (DIRECTIONAL).
 - SENSITIVITY AND NOISE VALUES INDICATED ON THIS SPECIFICATION ARE VALID AT 50% HUMIDITY.
 - CAPACITANCE MEASUREMENT MADE WITH BOONTON MODEL 7200 OR EQUIVALENT WITH APPLIED AC VOLTAGE OF 15 mVOLTS AT 1 MHz AND 0 VDC. INCLUDES CIRCUIT CAPACITANCE IN PARALLEL WITH CAPACITOR.
 - MICROPHONE TESTED WITH RIGHT ANGLE TUBE 1mm INTERNAL DIAMETER GIVING A PORT SPACING OF 8.0 mm (SEE DIAGRAM).

PORT LOCATION	DC SUPPLY	AMPLIFIER CURRENT DRAIN	SENSITIVITY CHANGE ON REDUCING SUPPLY TO 0.9VDC	OMNIDIRECTIONAL "A" WEIGHTED NOISE (1 kHz EQUIV. SPL)	DIRECTIONAL	OUTPUT IMPEDANCE OHMS (EACH HALF)			CAPACITANCE ±50%	
						MIN.	NOM.	MAX.	1-2 HALF	1-3 BOTH
12S, 12K	1.3V	100 µA MAX. FOR PAIR	3 dB MAX.	29.0 MAX.	-96.0 dB MAX. re MAX. re 1V	2800	4400	6800	13pF	26pF

CAPACITANCE PROBE POINTS

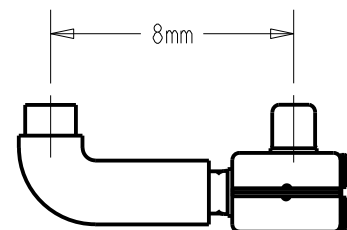
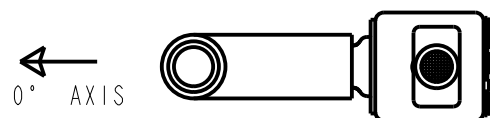
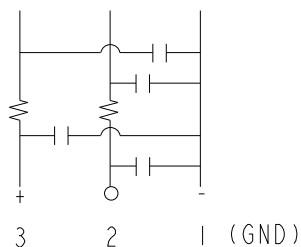

SCALE 4:1

Revision	C.O. #	Implementation Date	RELEASE LEVEL	REVISION
E	M10103591	5-11-10	Active	E
D	M10102980	7-30-09		

KNOWLES ELECTRONICS
ITASCA, ILLINOIS U.S.A.

WHEN TEST LIMITS ARE USED TO ESTABLISH INCOMING INSPECTION ACCEPTANCE/REJECTION CRITERIA, CORRELATION OF TEST EQUIPMENT WITH KNOWLES IS ALSO REQUIRED FOR ELIMINATION OF EQUIPMENT AND TEST METHOD VARIATION

TITLE: **MICROPHONE** TP-24605-000
PERFORMANCE SPECIFICATION SHT 2.1

DR. BY	DATE
MMM	2-13-06
CK. BY	DATE
GJP	2-15-06
APP. BY	DATE
GJP	2-15-06