

FB-EI-30026-000

SHT 1.1

NOTES:
1. LASER MARK, SEE WORK INSTRUCTION.

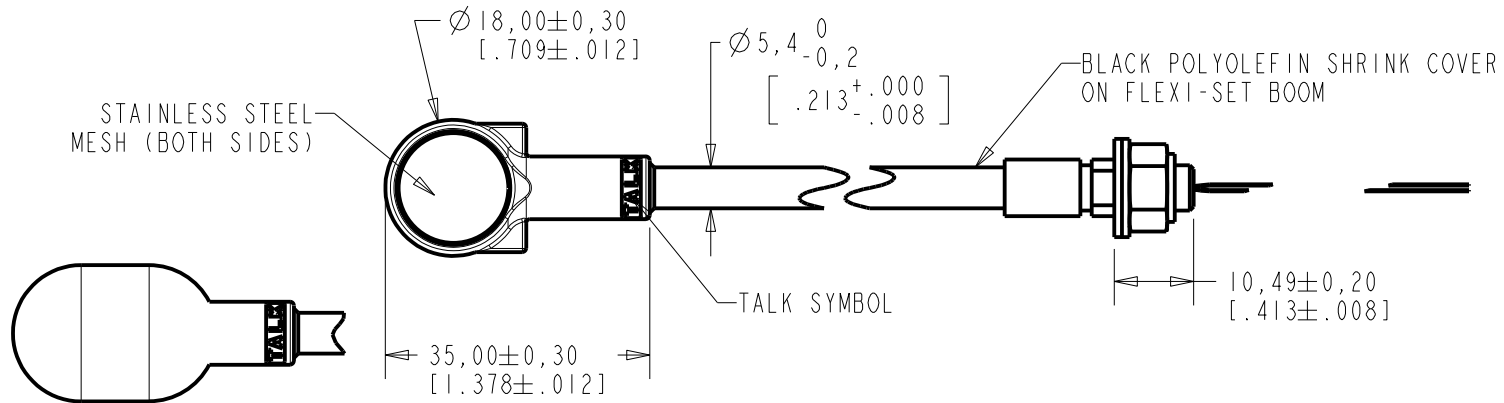

TOP VIEW
W/ WINDSHIELD SHOWN
SCALE 1:1

RED CONTROLLED

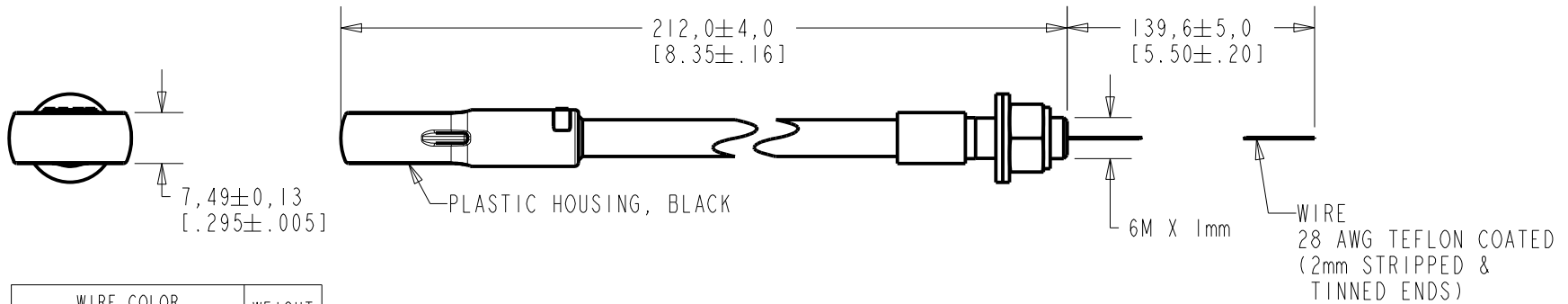

WIRE COLOR		WEIGHT GRAMS
+ve	OUTPUT	
RED	-	BLACK t.b.d.

DIMENSIONS IN MILLIMETERS [INCHES]

Revision	C.O. #	Implementation Date	RELEASE LEVEL	REVISION
H	C40101206	3-4-13	Active	H
G	C40100594	2-28-11		

KNOWLES ELECTRONICS
ITASCA, ILLINOIS U.S.A.

SCALE: 1:1	DR. BY: CRG	DATE: 4-28-08
DO NOT SCALE DRAWING	CK. BY: GJP	DATE: 8-4-06
TITLE: BOOM MICROPHONE	APP. BY: GJP	DATE: 8-4-06
OUTLINE DRAWING	FB-EI-30026-000 SHT 1.1	

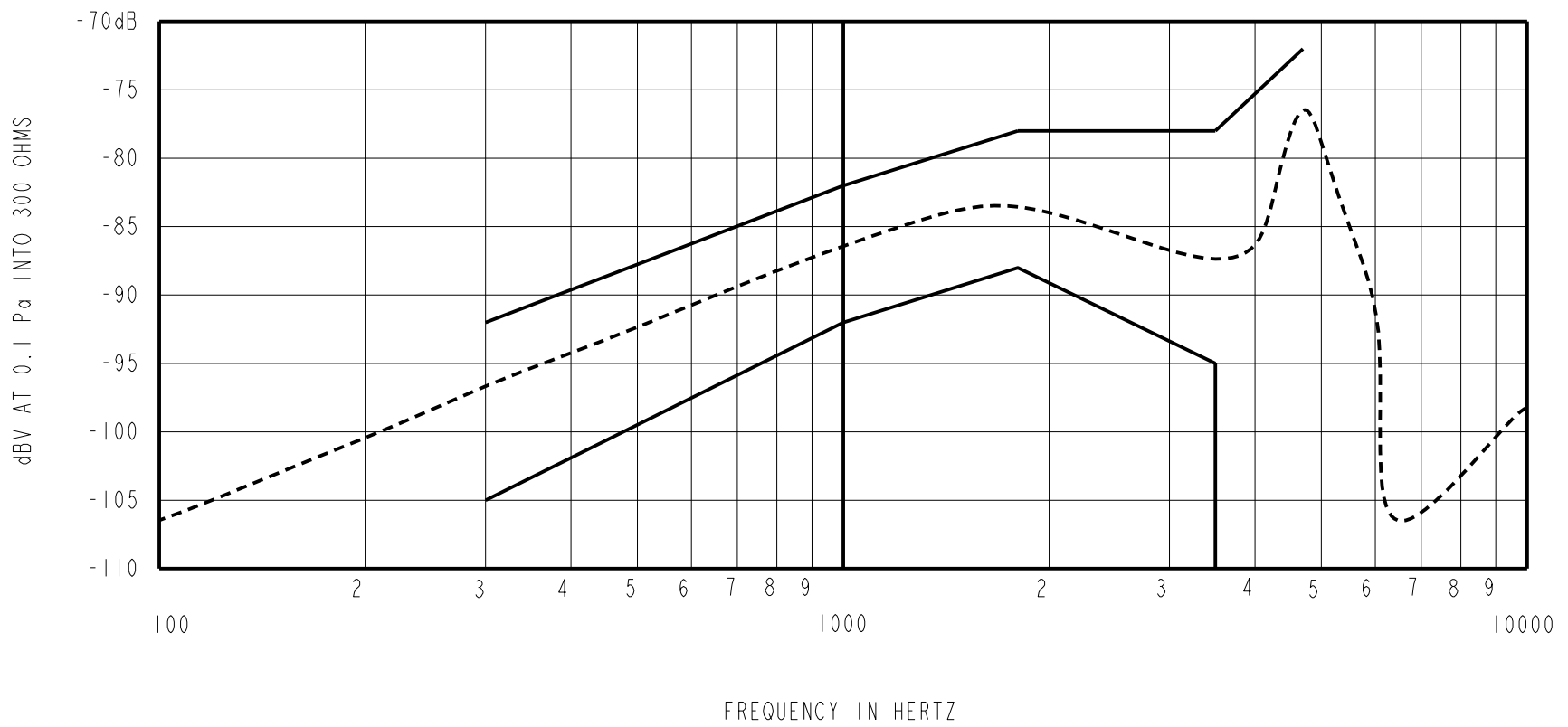

NOTES:

1. SENSITIVITY VALUES INDICATED ON THIS SPECIFICATION ARE VALID AT 50% HUMIDITY.
2.

FREQUENCY	SENSITIVITY		
	NIN.	NOM.	MAX.
300	-105	-97.5	-92
1000	-92	-87	-82
1800	-88	-83	-78
3500	-95	-87.5	-78
4000	---	-86.5	---
4700	---	-76.5	-72
3. TEST CONDITIONS:
HEAD OF BOOM EXPOSED TO 94 dB SPL SWEPT SOUND FIELD AT 6mm FROM VOICE APERTURE.
ARTIFICIAL VOICE:
B & k 4227 MOUTH SIMULATOR.
4. FOR MICROPHONE CAPSULE SPEC. SEE DRAWING BJ-28471-000 SHEET 2.1.

RED CONTROLLED

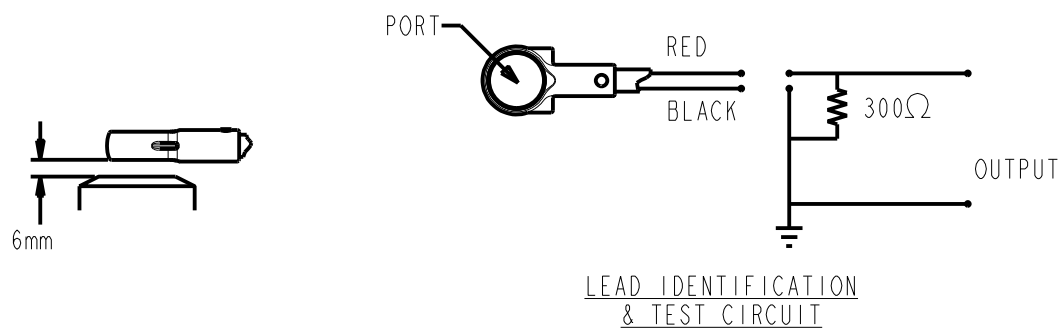

Revision	C.O. #	Implementation Date	RELEASE LEVEL	REVISION
H	C40101206	3-4-13	Active	H
G	C40100594	2-28-11		
WHEN TEST LIMITS ARE USED TO ESTABLISH INCOMING INSPECTION ACCEPTANCE/REJECTION CRITERIA, CORRELATION OF TEST EQUIPMENT WITH KNOWLES IS ALSO REQUIRED FOR ELIMINATION OF EQUIPMENT AND TEST METHOD VARIATION				
TITLE: BOOM MICROPHONE			FB-EI-30026-000	DR. BY DATE CRG 4-28-08
PERFORMANCE SPECIFICATION			SHT 2.1	CK. BY DATE GJP 8-4-06
				APP. BY DATE GJP 8-4-06

KNOWLES ELECTRONICS
ITASCA, ILLINOIS U.S.A.

FB-EI-30026-000

PROPRIETARY NOTE: THIS DOCUMENT CONTAINS INFORMATION WHICH IS THE PROPRIETARY PROPERTY OF KNOWLES ELECTRONICS, LLC. OR ITS AFFILIATED ENTITIES. IT IS ISSUED TO YOU FOR YOUR INFORMATION ONLY AND IS NOT TO BE REPRODUCED OR TRANSMITTED IN ANY FORM OR BY ANY MEANS, ELECTRONIC OR MECHANICAL, INCLUDING PHOTOCOPYING, RECORDING, OR BY ANY INFORMATION STORAGE AND RETRIEVAL SYSTEM, WITHOUT THE WRITTEN PERMISSION OF KNOWLES ELECTRONICS, LLC.

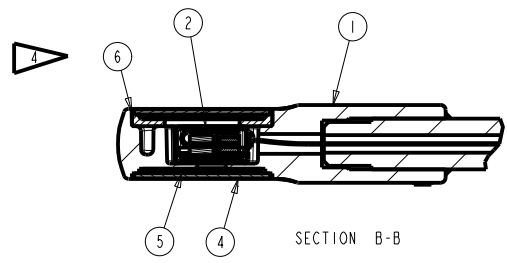
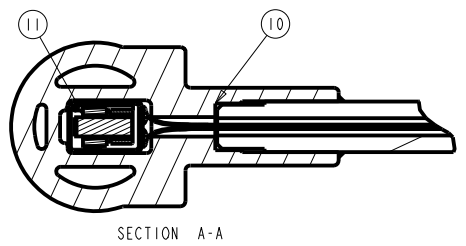

NOTES:

1. ITEM NUMBERS (SHOWN THUS **b**) ON DRAWING CORRESPOND WITH ITEM NUMBERS ON BILL OF MATERIAL.
- (D) 2 ATTACH ITEM **2** TO ITEM **1** IN 4 PLACES MINIMUM ON EACH SIDE USING CEMENT (ITEM **11**).
- (D) 3 SEAL BOOM END WITH ITEM **12**. BUILD UP TO BE 2mm MAX.
- (A) 4 WATERPROOF SEAL BETWEEN ITEMS **1** & **6** WITH CEMENT.
- (E) 5. ITEM **1** (FB-044) MUST USE VERSION F OR ABOVE.

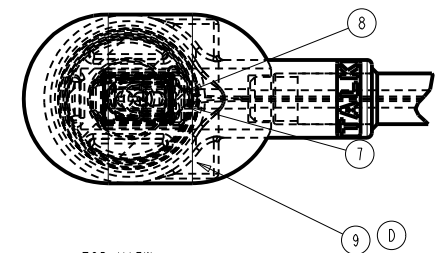

(4X), BOTH SIDES

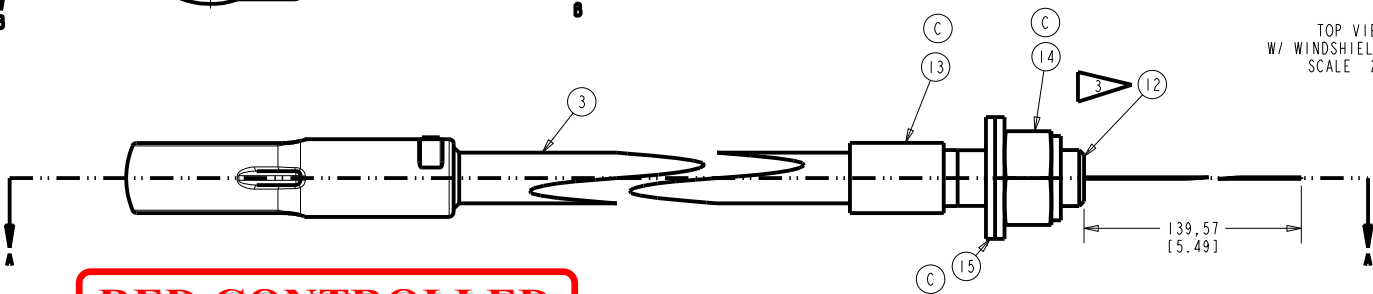
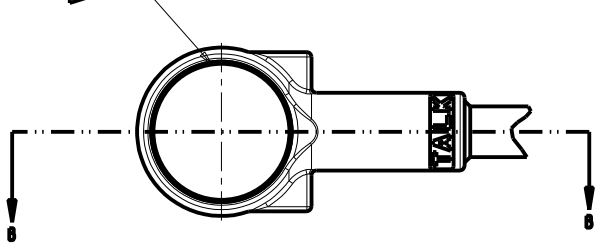

RED CONTROLLED

DIMENSIONS IN MILLIMETERS [INCHES]

RELEASE LEVEL		REVISION	
Active		H	
SCALE: 2:1		DO NOT SCALE DRAWING	
DR. BY	DATE	CRG	4-28-08
CH. BY	DATE	GJP	8-4-06
APP. BY	DATE	GJP	8-4-06
TITLE		FB-EI-30026-000	
BOOM MICROPHONE ASSEMBLY		SHEET 3.1	

MATERIAL		SEE BILL OF MATERIALS	FINISH
REF. ID-1747	F I.c.o. C10107747	RENAME IN PROJE FROM FB-30026-000 TO FB-EI-30026-000 III 8-11-08	UNLESS OTHERWISE SPECIFIED, DIMENSIONS ARE IN INCHES
	G I.c.o. C40100594	REVISE CABLE LENGTH AND WEIGHT IN INCHES CW 2-28-11	
	H I.c.o. C40101206	UPDATE THE REVISION 00 3-4-13	THIRD ANGLE PROJECTION

KNOWLES ELECTRONICS
ITASCA, ILLINOIS U.S.A.

FB-EI-30026-000 Sheet 4.1		KNOWLES ELECTRONICS ITASCA, ILLINOIS U.S.A.		FB-EI-30026-000 Sheet 4.1	
Dr. By Date CRG 4-28-08	Subject: BOOM MICROPHONE ASSEMBLY			Revision H	
Ch. GJP 8-4-06 App. GJP 8-4-06				Release Level Active	
COL. 1	2	3	4		
Part or Dwg. no.	Tot. Req.	Nomenclature:	Applicable Specs or Remarks	Item No.	Line No.
FB-044	1	HOUSING		1	1
BJ-28471-000	1	MICROPHONE ASSEMBLY		2	2
FB-189-172	1	FLEXIBLE BOOM 5.4 mm		3	3
FB-037	2	SCREEN DISC		4	4
H FB-234	2	MEMBRANE		5	5
E FB-045	1	COVER		6	6
E FB-070-011	1	WIRE BLACK TEFLON		7	7
E FB-070-008	1	WIRE RED TEFLON		8	8
FB-042	1	WINDSHIELD		9	9
G 13-092-080102	A/R	CEMENT		10	10
13-092-120103	A/R	CEMENT		11	11
13-591	A/R	SILICONE SEALANT		12	12
FB-201	1	BULKHEAD CONNECTOR		13	13
FB-051	1	NUT		14	14
FB-052	2	WASHER		15	15

RED CONTROLLED

REVISION	F c.o. C10107747	RENAME IN PRO/E FROM FB-30026-000 TO FB-EI-30026-000 TT 8-11-08		G c.o. C40100594	REVISE CABLE LENGTH AND CEMENT PN CW 2-28-11	H c.o. C40101206	FB-234 WAS FB-038 00 3-4-13	FB-EI-30026-000 Sheet 4.1
PROPRIETARY NOTE: THIS DOCUMENT CONTAINS INFORMATION WHICH IS THE PROPRIETARY PROPERTY OF KNOWLES ELECTRONICS, LLC. OR ITS AFFILIATED ENTITIES. IT IS ISSUED IN STRICT CONFIDENCE AND SHALL NOT BE REPRODUCED, COPIED, USED, OR DISCLOSED TO ANY THIRD PARTY PARTIALLY OR WHOLLY IN ANY MANNER WITHOUT PRIOR WRITTEN PERMISSION OF, AND MUST BE RETURNED UPON REQUEST BY, KNOWLES ELECTRONICS, LLC.								

REF: 300-PART-00-PW REF: 0