

FB-EM-30343-000  
SHT 1.1

**RED CONTROLLED**

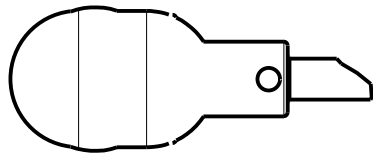

TOP VIEW  
W/WINDSHIELD SHOWN  
SCALE 1:1

$\varnothing 19,0 \pm 0,3$   
[.748 ± .012]

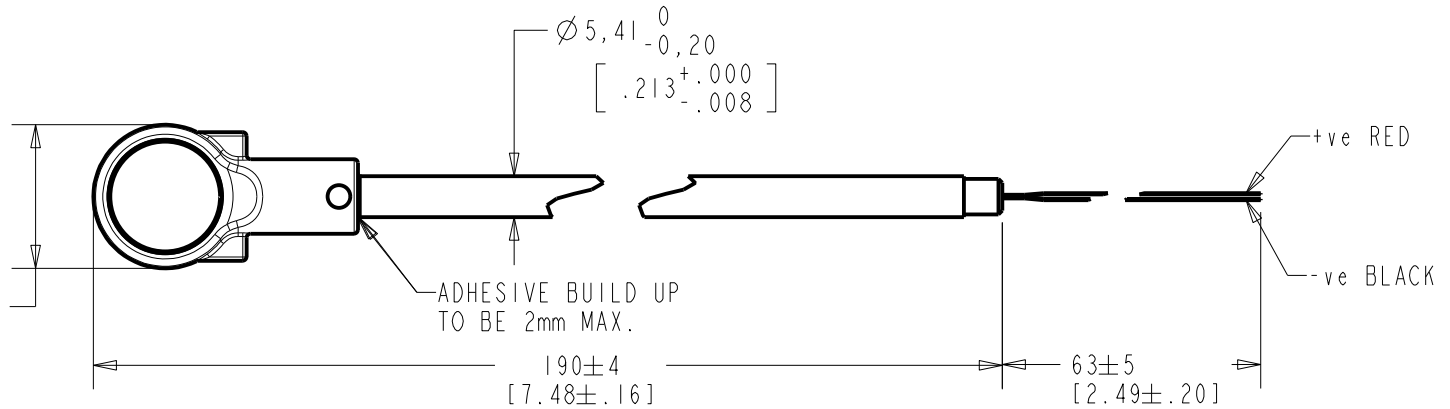

PLASTIC HOUSING, BLACK



$6,10 \pm 0,12$   
[.240 ± .005]

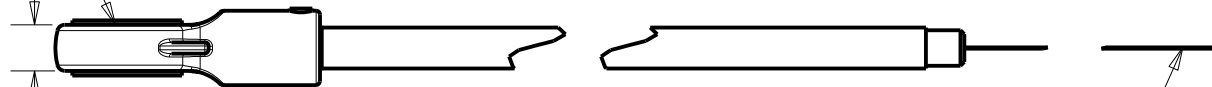

WIRES  
2mm STRIPPED & TINNED ENDS

WIRE COLOR			WEIGHT GRAMS
+ve	OUTPUT	-ve	
RED	---	BLACK	---

DIMENSIONS IN MILLIMETERS [INCHES]

Revision	C.O. #	Implementation Date	RELEASE LEVEL	REVISION
C	C40101206	3-7-13	Active	C
B	C10107748	8-12-08		
A	C10107379	6-26-08		

SCALE:

1:1

DO NOT SCALE DRAWING

TITLE:

BOOM MICROPHONE FB-EM-30343-000

OUTLINE DRAWING

SHT 1.1

DR. BY	DATE
TT	6-26-08
CK. BY	DATE
GJP	7-15-08
APP. BY	DATE
GJP	7-15-08

**KNOWLES ELECTRONICS**  
ITASCA, ILLINOIS U.S.A.

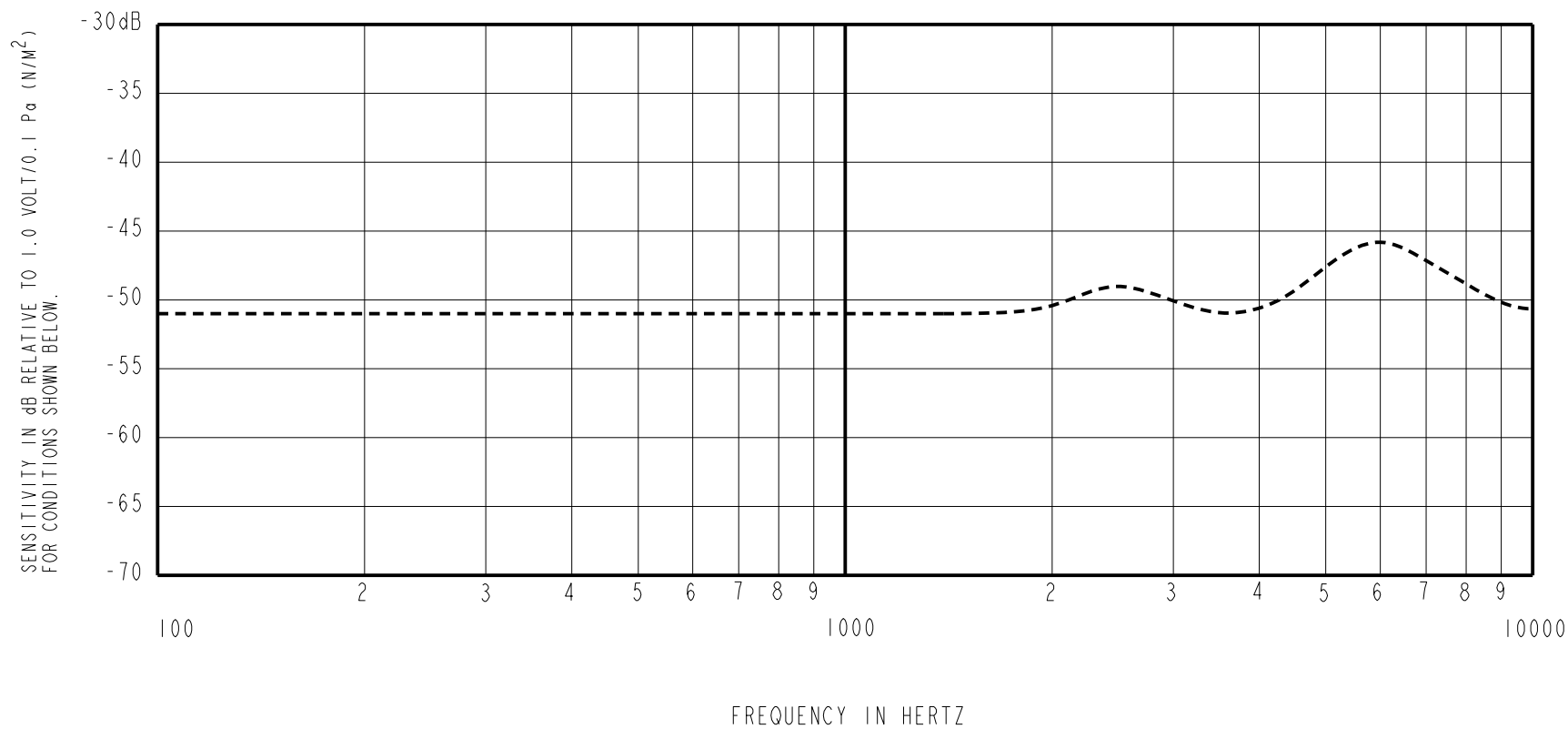

FREQUENCY	SENSITIVITY			DEVICE CONFORMITY	
	MIN.	NOM.	MAX.	RANGE OF DEVIATION FROM 1KHz	
300	---	-51.0	---	-4.0	+4.0
1000	-55.0	-51.0	-47	0.0	0.0
2000	---	-50.5	---	-4.0	---
6000	---	-46.5	---	0.0	+9

**RED CONTROLLED**

NOTES:

- MICROPHONE TO BE FUNCTIONAL WITH 10 VDC SUPPLY.
- SENSITIVITY VALUES INDICATED ON THIS SPECIFICATION ARE VALID AT 50% HUMIDITY.
- TEST CONDITIONS:  
HEAD OF BOOM EXPOSED TO 74 dB SPL SWEPT SOUND FIELD AT 6mm FROM VOICE APERTURE.  
ARTIFICIAL VOICE:  
B & k 4227 MOUTH SIMULATOR.
- FOR MICROPHONE CAPSULE SPEC. SEE DRAWING WP-25993-D63
- SURVIVES 3m SUBMERSION BASED ON QUALIFICATION TESTING. 100% TEST 30 MINUTES 1m SUBMERSION; SENSITIVITY WITHIN 3dB OF INITIAL SENSITIVITY AFTER DRIED FOR 30 MINUTES AT ROOM TEMPERATURE.

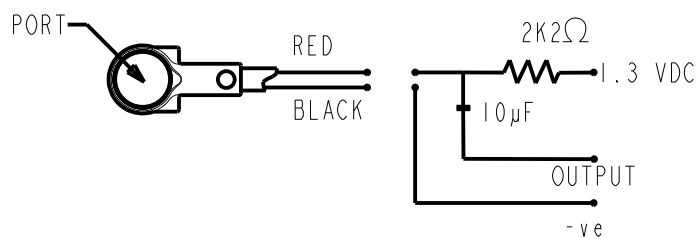
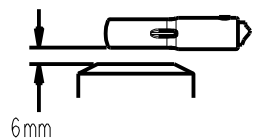

LEAD IDENTIFICATION & TEST CIRCUIT

Revision	C.O. #	Implementation Date	RELEASE LEVEL	REVISION
C	C40101206	3-7-13	Active	C
B	C10107748	8-12-08		
A	C10107379	6-26-08		

**KNOWLES ELECTRONICS**  
ITASCA, ILLINOIS U.S.A.

WHEN TEST LIMITS ARE USED TO ESTABLISH INCOMING INSPECTION ACCEPTANCE/REJECTION CRITERIA, CORRELATION OF TEST EQUIPMENT WITH KNOWLES IS ALSO REQUIRED FOR ELIMINATION OF EQUIPMENT AND TEST METHOD VARIATION

TITLE: **BOOM MICROPHONE FB-EM-30343-000**  
PERFORMANCE SPECIFICATION **SHT 2.1**

DR. BY	DATE
TT	6-26-08
CK. BY	DATE
GJP	7-15-08
APP. BY	DATE
GJP	7-15-08

FB-EM-30343-000

PROPRIETARY NOTE: THIS DOCUMENT CONTAINS INFORMATION WHICH IS THE PROPRIETARY PROPERTY OF KNOWLES ELECTRONICS, LLC. OR ITS RELATED ENTITIES. IT IS ISSUED TO YOU FOR YOUR INFORMATION ONLY. IT IS NOT TO BE REPRODUCED OR TRANSMITTED IN ANY FORM OR BY ANY MEANS, ELECTRONIC OR MECHANICAL, INCLUDING PHOTOCOPYING, RECORDING, OR BY ANY INFORMATION STORAGE AND RETRIEVAL SYSTEM, WITHOUT THE WRITTEN PERMISSION OF, AND MUST BE RETURNED UPON REQUEST BY, KNOWLES ELECTRONICS, LLC.

**RED CONTROLLED**

NOTES:

1. ITEM NUMBERS (SHOWN THUS **b**) ON DRAWING CORRESPOND WITH ITEM NUMBERS ON BILL OF MATERIAL.
2. ATTACH ITEM **4** TO ITEM **1** IN 4 PLACES MINIMUM ON EACH SIDE USING CEMENT.
3. SEAL BOOM END WITH ITEM **10**. BUILD UP TO BE 2mm MAX.
4. SEAL WHOLE HEAD CAVITY WITH ITEM **9**, WIRE HOLE MUST BE FILLED, ADHESIVE BUILD UP TO BE 2mm MAX.

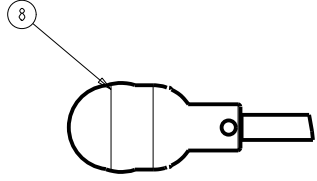
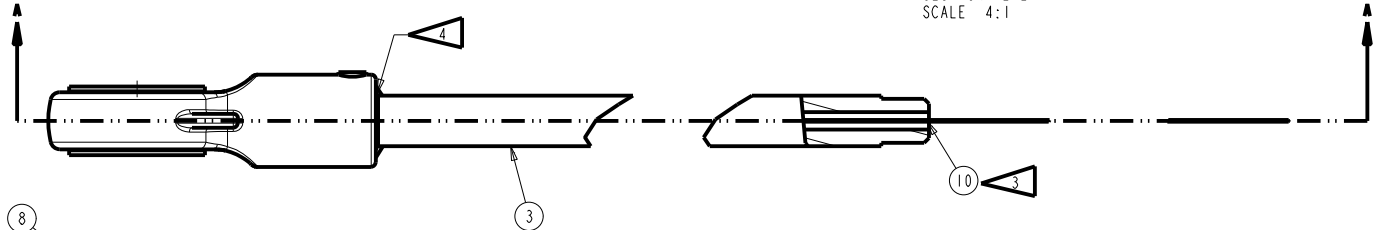
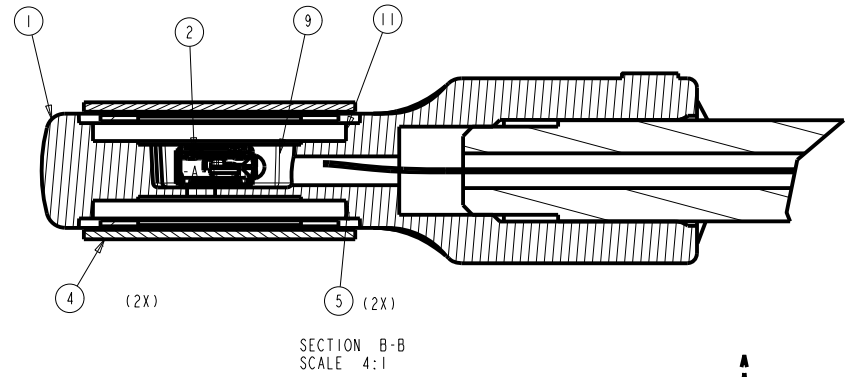
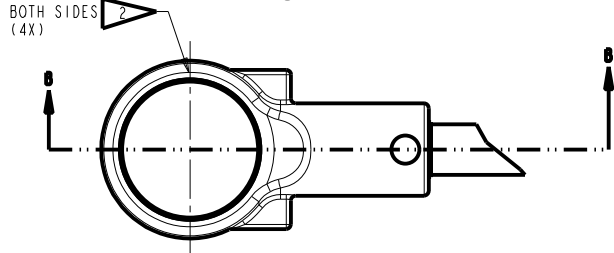
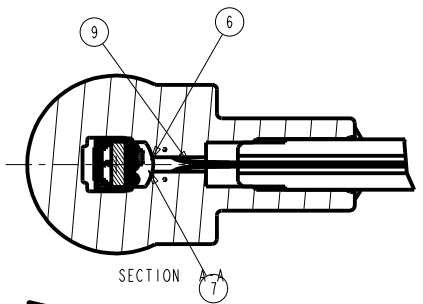

DIMENSIONS IN MILLIMETERS [INCHES]

MATERIAL		SEE BILL OF MATERIALS		FINISH		RELEASE LEVEL	REVISION
REF. 10-1747	A C10107379					Active	C
	B C10107748					SCALE: 2:1	DO NOT SCALE DRAWING
RENAME IN PROZE FROM FB-30243-000 TO FB-EM-30343-000 11.8.12-08		C C40101206		UNLESS OTHERWISE SPECIFIED, DIMENSIONS ARE IN INCHES		DR. BY DATE TT 6-26-08	
UPDATE THE REVISION 00 3-7-13				THIRD ANGLE PROJECTION		CH. BY DATE GJP 7-15-08	
				TITLE		APP. BY DATE GJP 7-15-08	
				BOOM MICROPHONE ASSEMBLY		FB-EM-30343-000	
						SHEET 3.1	

KEY: 131, BS: SIZE, FPM REV: 0

<b>FB-EM-30343-000</b>			<b>KNOWLES ELECTRONICS</b>		<b>FB-EM-30343-000</b>		
Sheet <b>4.1</b>			ITASCA, ILLINOIS U.S.A.		Sheet <b>4.1</b>		
Dr.	By	Date	Subject:	<b>BOOM MICROPHONE ASSEMBLY</b>	Revision		
Ch.	GJP	7-15-08			<b>C</b>	Release Level	
App.	GJP	7-15-08				<b>Active</b>	

COL. 1	2	3	4	Item No.	Line No.
Part or Dwg. no.	Tot. Req.	Nomenclature:	Applicable Specs or Remarks		
FB-218-500	1	HOUSING		1	1
WP-25993-D63	1	MICROPHONE ASSEMBLY		2	2
FB-189-167	1	FLEXIBLE BOOM 6 mm		3	3
FB-223	2	SCREEN DISC		4	4
FB-234	2	MEMBRANE		5	5
FB-070-050	1	WIRE BLACK TEFLON		6	6
FB-070-049	1	WIRE RED TEFLON		7	7
FB-042	1	WINDSHIELD		8	8
13-092-120101	A/R	CEMENT		9	9
13-591	A/R	SILICONE SEALANT		10	10
13-092-130102	A/R	CEMENT		11	11

**RED CONTROLLED**

<b>REVISION</b>	A	c.o. C10107379
	B	c.o. C10107748
	RENAME IN PROFE FROM FB-30343-000 TO FB-EM-30343-000 TT 8-12-08	
C	c.o. C40101206	
FB-234 WAS FB-038 00 3-7-13		

**FB-EM-30343-000**  
Sheet **4.1**

PROPRIETARY NOTE: THIS DOCUMENT CONTAINS INFORMATION WHICH IS THE PROPRIETARY PROPERTY OF KNOWLES ELECTRONICS, LLC. OR ITS AFFILIATED ENTITIES. IT IS ISSUED IN STRICT CONFIDENCE AND SHALL NOT BE REPRODUCED, COPIED, USED, OR DISCLOSED TO ANY THIRD PARTY PARTIALLY OR WHOLLY IN ANY MANNER WITHOUT PRIOR WRITTEN PERMISSION OF, AND MUST BE RETURNED UPON REQUEST BY, KNOWLES ELECTRONICS, LLC.

REF: 300-FRM-00-FRM REF: 0