

BL-23497-000
SHT 1.1

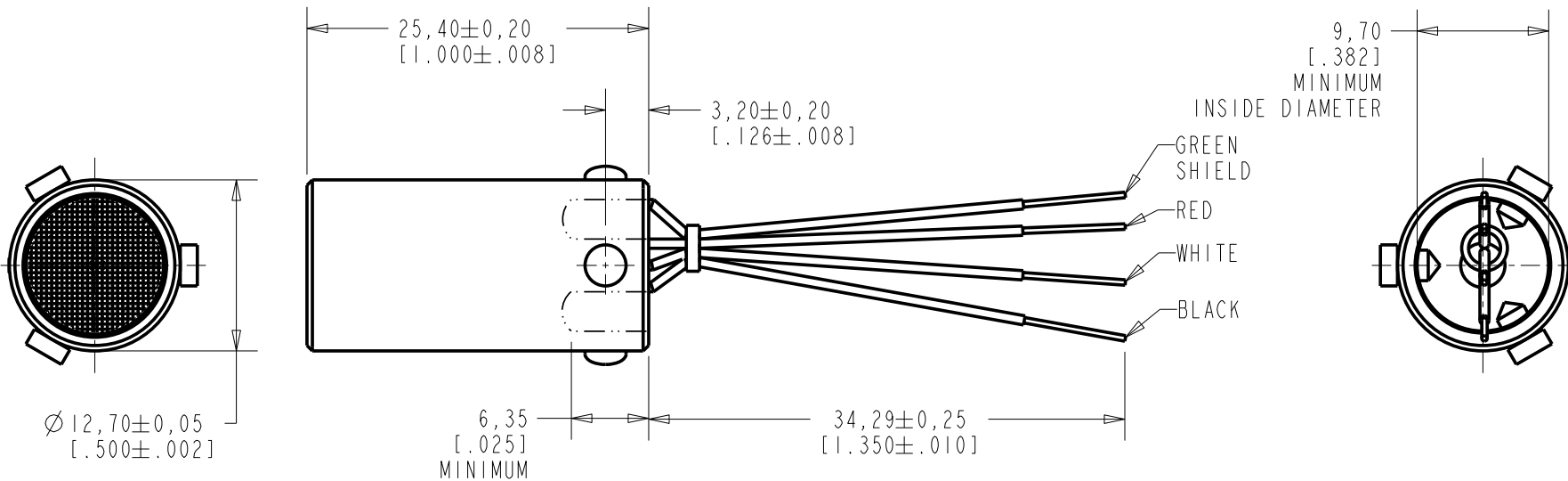

NOMINAL WEIGHT
27.0 GRAMS

DIMENSIONS IN MILLIMETERS [INCHES]

KNOWLES ELECTRONICS
ITASCA, ILLINOIS U.S.A.

Revision	C.O. #	Implementation Date	RELEASE LEVEL	REVISION
B	MI0103141	11-09-09	Active	B
A	MI0101208	10-30-06		
SCALE: 2:1				
DO NOT SCALE DRAWING			DR. BY	DATE
TITLE: MICROPHONE			MMM	10-30-06
OUTLINE DRAWING			CK. BY	DATE
BL-23497-000			GJP	11-6-06
SHT 1.1			APP. BY	DATE
			GJP	11-6-06

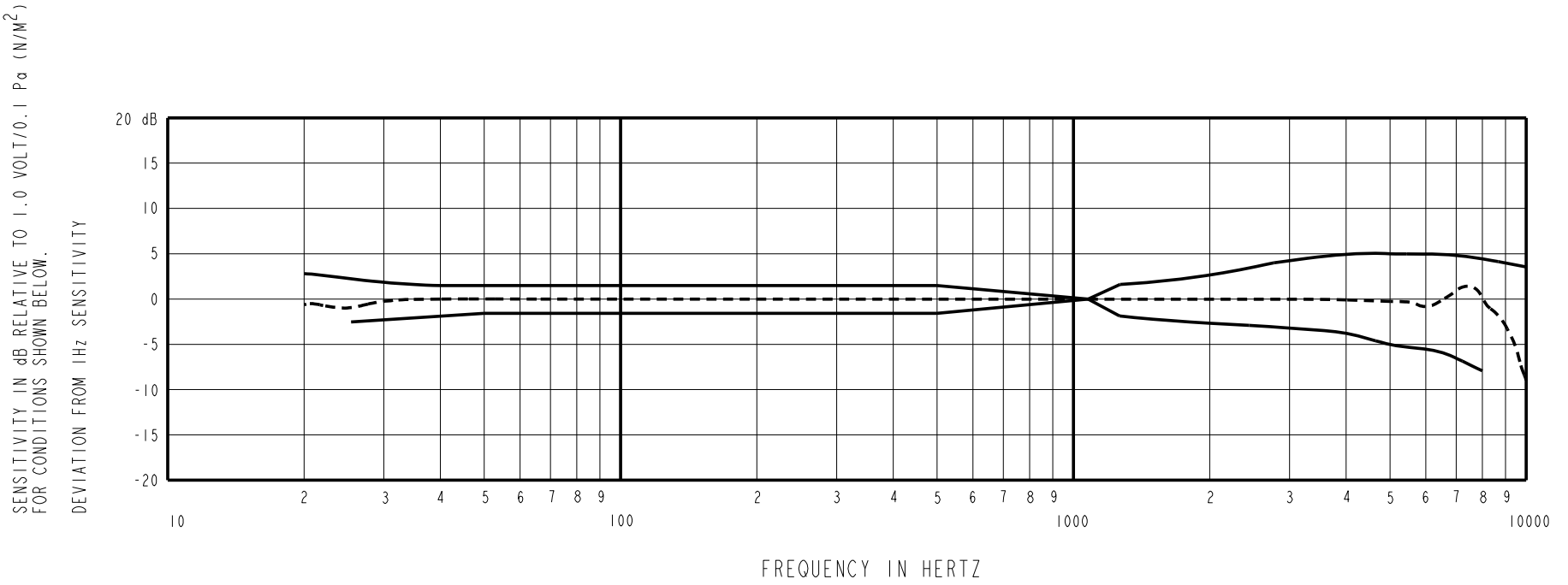

FREQUENCY	SENSITIVITY			DEVICE CONFORMITY	
	MIN.	NOM.	MAX.	RANGE OF DEVIATION FROM 1 kHz	
20	---	---	---	---	+3.0
25	---	---	---	-4.0	+2.0
31.5	---	---	---	-3.0	+1.5
40	---	---	---	-2.0	+1.0
50	---	---	---	-1.0	+1.0
800	---	---	---	-1.0	+1.0
1000	-72.0	-69.0	-66.0	0.0	0.0
1250	---	---	---	-1.5	+1.5
1600	---	---	---	-2.0	+2.0
2000	---	---	---	-2.5	+2.5
2500	---	---	---	-3.0	+3.5
3150	---	---	---	-3.5	+4.5
4000	---	---	---	-4.0	+5.0
5000	---	---	---	-5.0	+5.0
6300	---	---	---	-6.0	+5.0
8000	---	---	---	-7.5	+4.5
10000	---	---	---	---	+3.5

NOTES:

- CASE CONNECTED TO NEGATIVE TERMINAL.

DC SUPPLY	BATTERY CURRENT DRAIN	"A" WEIGHTED NOISE (1 kHz EQUIV. SPL) IN 3 WIRE MODEL	OUTPUT IMPEDANCE OHMS			OUTER HOUSING TO SHIELD	
			MIN.	NOM.	MAX.	MIN.	MAX.
3.0 V	160 μ A MAX.	34 dB MAX.	---	4000	---	---	3.0 Ω

TEST CONDITIONS

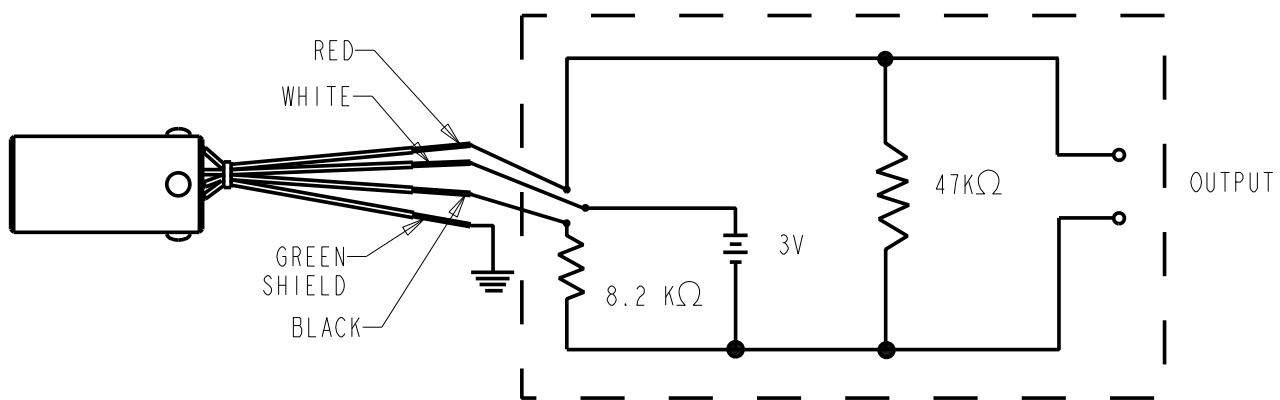

Revision	C.O. #	Implementation Date	RELEASE LEVEL	REVISION
B	M10103141	11-09-09	Active	B
A	M10101208	10-30-06		

KNOWLES ELECTRONICS
ITASCA, ILLINOIS U.S.A.

WHEN TEST LIMITS ARE USED TO ESTABLISH INCOMING INSPECTION ACCEPTANCE/REJECTION CRITERIA, CORRELATION OF TEST EQUIPMENT WITH KNOWLES IS ALSO REQUIRED FOR ELIMINATION OF EQUIPMENT AND TEST METHOD VARIATION

TITLE: **MICROPHONE**
PERFORMANCE SPECIFICATION

BL-23497-000
SHT 2.1

DR. BY	DATE
MMM	10-30-06
CK. BY	DATE
GJP	11-6-06
APP. BY	DATE
GJP	11-6-06