

FED-27423-106

SHT 1.1

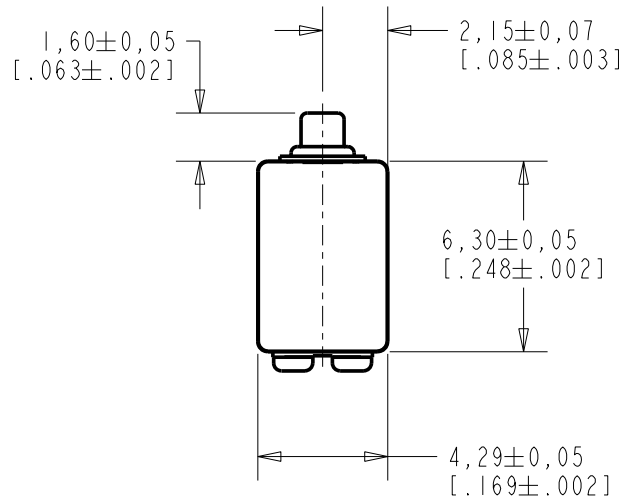

NOTE:

- 1 A POSITIVE GOING VOLTAGE AT TERMINAL 2, RELATIVE TO TERMINAL 1, CAUSES A DECREASE IN PRESSURE AT THE SOUND OUTLET.
- 2 LOCATED FROM TWO SURFACES FOR CUSTOMER CONVENIENCE. ONLY APPLICABLE FROM ONE SURFACE, NOT TO BE USED TOGETHER. HORIZONTAL LOCATION FOR TERMINAL CENTERED TO $\pm 0,17$ [.007].

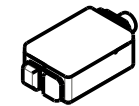
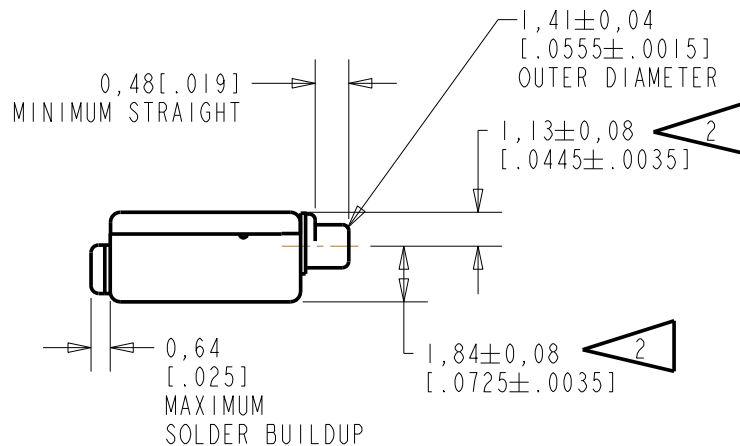
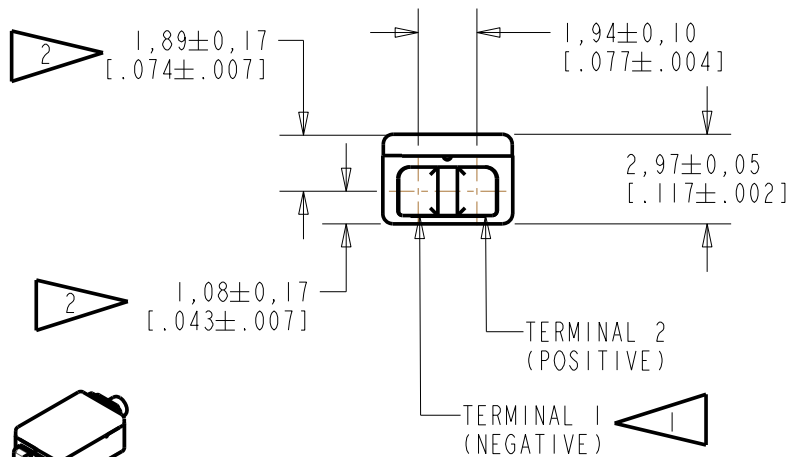

SCALE 2:1

NOMINAL WEIGHT
.31 GRAMS

DIMENSIONS IN MILLIMETERS [INCHES]

Revision	C.O. #	Implementation Date	RELEASE LEVEL	REVISION
B	C10107990	11-13-08	Active	B
A	C10103609	2-2-06		

SCALE: 4:1		DR. BY	DATE
DO NOT SCALE DRAWING		CRG	2-2-06
TITLE: RECEIVER		CK. BY	DATE
OUTLINE DRAWING		GJP	2-8-06
FED-27423-106		APP. BY	DATE
SHT 1.1		GJP	2-8-06

KNOWLES ELECTRONICS
ITASCA, ILLINOIS U.S.A.

THE FED-27423-106 IS A FERROFLUID AND TYPE III DAMPED ED-29457 RECEIVER WITH A PEAK OF 6dB RELATIVE TO THE SENSITIVITY AT 1kHz UNDER CONSTANT VOLTAGE DRIVE CONDITIONS.

FERROFLUID DAMPING AND
TYPE III DAMPING

FED-27423-106
SHEET 2.1

CONSTANT VOLTAGE DRIVE CONDITIONS

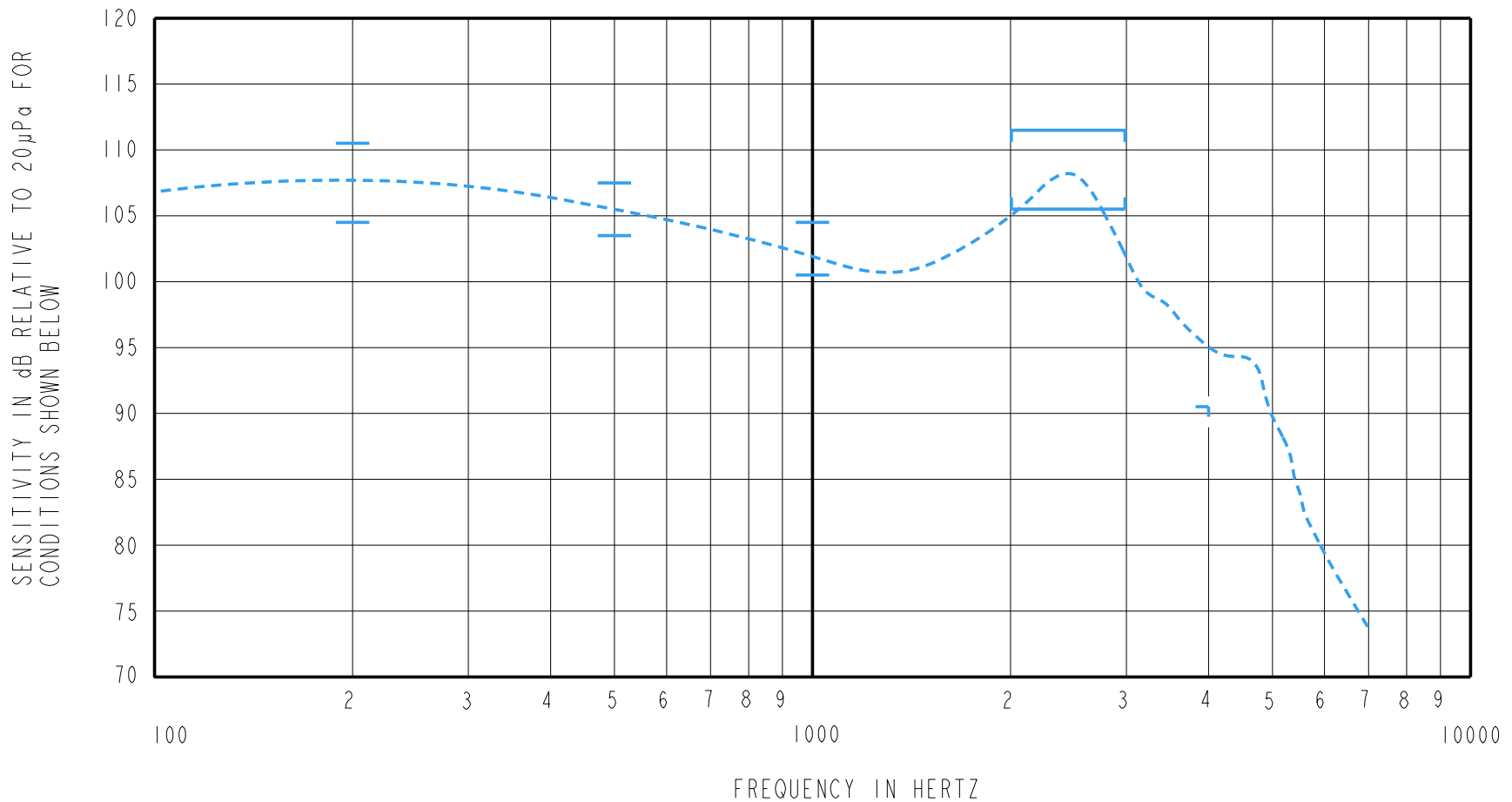

ACOUSTICAL

SENSITIVITY
DEVICE WILL PRODUCE THE SPL LISTED BELOW UNDER TEST CONDITIONS DESCRIBED IN TABLE 3.
NOMINAL SENSITIVITY AT 1kHz IS dB RELATIVE TO 20µPa. ALL OTHER VALUES
IN dB RELATIVE TO THE SENSITIVITY AT 1kHz.

FREQUENCY (Hz)	MINIMUM	NOMINAL	MAXIMUM
200	+2.0	+5.0	+8.0
500	+1.0	+3.0	+5.0
1000	-2.0	102.5	+2.0
2000 - 3000	+3.0	+6.0	+9.0
4000	-12.0	---	---

PORT LOCATION: 12C

TABLE 1

TOTAL HARMONIC DISTORTION
DEVICE WILL NOT EXCEED TOTAL HARMONIC DISTORTION LEVELS LISTED BELOW.

FREQUENCY (Hz)	AC DRIVE (V rms)	DC BIAS (mA)	LIMIT (%)
500	1.203	0	10
830	0.427	0	5
1250	0.427	0	5

TABLE 2

TEST CONDITIONS

NOMINAL SOURCE VOLTAGE	0.427 V rms, 0mA DC BIAS
SOURCE IMPEDANCE	<1 Ohm
TUBING	10mm [.394"] LONG, 1mm [.039"] I.D.
COUPLER CAVITY	2 CM ³ , SIMULATED ANSI S3.7 TYPE HA-3 (IEC 126)

TABLE 3

ELECTRICAL

DC RESISTANCE	196 OHMS ± 10%
IMPEDANCE @ 500 Hz	380 OHMS ± 15%
IMPEDANCE @ 1 kHz	680 OHMS ± 15%

TABLE 4

ISOLATION: CASE WILL BE ELECTRICALLY ISOLATED FROM THE COIL CIRCUIT.

TEMPERATURE: OPERATING RANGE FROM 0°C TO 63°C (SENSITIVITY WILL NOT VARY BY MORE THAN ±3 dB WITHIN RANGE)
SENSITIVITY AT 0°C IS 2dB LOWER THAN THE SENSITIVITY AT ROOM TEMPERATURE.
DELTA PEAK IS 1dB HIGHER AT BODY TEMPERATURE (37°C)
STORAGE RANGE FROM -40°C TO 63°C.

Revision	C.O. #	Implementation Date	RELEASE LEVEL	REVISION
B	C10107990	11-13-08	Active	B
A	C10103609	2-2-06		
WHEN TEST LIMITS ARE USED TO ESTABLISH INCOMING INSPECTION ACCEPTANCE/REJECTION CRITERIA, CORRELATION OF TEST EQUIPMENT WITH KNOWLES IS ALSO REQUIRED FOR ELIMINATION OF EQUIPMENT AND TEST METHOD VARIATION				
TITLE: RECEIVER			FED-27423-106	DR. BY DATE CRG 2-2-06
PERFORMANCE SPECIFICATION			SHT 2.1	CK. BY DATE GJP 2-8-06
				APP. BY DATE GJP 2-8-06

KNOWLES ELECTRONICS
ITASCA, ILLINOIS U.S.A.