



**RM Series**  
**GPS Receiver Module**  
**Data Guide**

**Wireless made simple<sup>®</sup>**

 **Warning:** Linx radio frequency (“RF”) products may be used to control machinery or devices remotely, including machinery or devices that can cause death, bodily injuries, and/or property damage if improperly or inadvertently triggered, particularly in industrial settings or other applications implicating life-safety concerns. No Linx Technologies product is intended for use in any application without redundancies where the safety of life or property is at risk.

The customers and users of devices and machinery controlled with RF products must understand and must use all appropriate safety procedures in connection with the devices, including without limitation, using appropriate safety procedures to prevent inadvertent triggering by the user of the device and using appropriate security codes to prevent triggering of the remote controlled machine or device by users of other remote controllers.

**All RF products are susceptible to RF interference that can prevent communication.** Lack of good sight of the GPS satellites (open sky) can affect the accuracy of a position fix or prevent a fix entirely.

**Do not use any Linx product over the limits in this data guide.** Excessive voltage or extended operation at the maximum voltage could cause product failure. Exceeding the reflow temperature profile could cause product failure which is not immediately evident.

**Do not make any physical or electrical modifications to any Linx product.** This will void the warranty and regulatory and UL certifications and may cause product failure which is not immediately evident.

 **Warning:** This product incorporates numerous static-sensitive components. Always wear an ESD wrist strap and observe proper ESD handling procedures when working with this device. Failure to observe this precaution may result in module damage or failure.



A large-print version of this document is available at [www.linxtechnologies.com](http://www.linxtechnologies.com).

# Table of Contents

1	<b>Description</b>
1	<b>Features</b>
1	<b>Applications Include</b>
2	<b>Ordering Information</b>
2	<b>Absolute Maximum Ratings</b>
2	<b>Electrical Specifications</b>
4	<b>Pin Assignments</b>
4	<b>Pin Descriptions</b>
5	<b>A Brief Overview of GPS</b>
6	<b>Time To First Fix (TTFF)</b>
6	<b>Module Description</b>
7	<b>Backup Battery</b>
7	<b>Power Supply Requirements</b>
7	<b>The 1PPS Output</b>
8	<b>Antenna Considerations</b>
9	<b>Power Control</b>
10	<b>Slow Start Time</b>
11	<b>Interfacing with NMEA Messages</b>
12	<b>NMEA Output Messages</b>
13	<b>GGA – Global Positioning System Fix Data</b>
14	<b>GLL – Geographic Position – Latitude / Longitude</b>
14	<b>GSA – GPS DOP and Active Satellites</b>
15	<b>GSV – GPS Satellites in View</b>
16	<b>RMC – Recommended Minimum Specific GPS Data</b>
17	<b>VTG – Course Over Ground and Ground Speed</b>
17	<b>Start-up Response</b>
18	<b>Input Messages</b>
20	<b>101 – Hot Re-start</b>
20	<b>102 – Warm Re-start</b>
20	<b>103 – Cold Re-start</b>

20	104 – Restore Default Configuration
20	161 – Standby Mode
21	220 – Position Fix Interval
22	223 – Extended Receive Time
23	225 – Receiver Duty Cycle
24	251 – Baud Rate
25	Position Fix Interval
26	DGPS Source
27	SBAS Enable
28	NMEA Output Messages
29	Set Datum
30	Static Navigation Threshold
31	<b>Typical Applications</b>
32	<b>Master Development System</b>
33	<b>Microstrip Details</b>
34	<b>Board Layout Guidelines</b>
35	<b>Pad Layout</b>
36	<b>Production Guidelines</b>
36	<b>Hand Assembly</b>
36	<b>Automated Assembly</b>
37	Reflow Temperature Profile
37	Shock During Reflow Transport
37	Washability
38	<b>Appendix A</b>
46	<b>Resources</b>
46	Support
46	RF Design Services
46	Antenna Factor Antennas
47	<b>Notes</b>

## RM Series GPS Receiver

# Data Guide



### Description

The RM Series GPS receiver module is a self-contained high-performance Global Positioning System receiver. Based on the MediaTek MT3337 chipset, it can simultaneously acquire on 66 channels and track on up to 22 channels. This gives the module fast lock times and high position accuracy even at low signal levels.

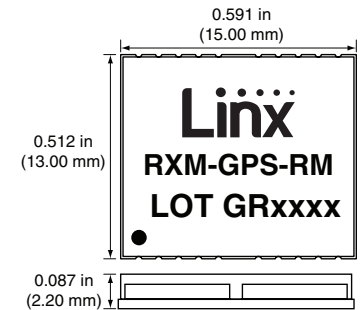

Figure 1: Package Dimensions

The module's exceptional sensitivity gives it superior performance, even in dense foliage and urban canyons. Its very low power consumption helps maximize runtimes in battery powered applications. The module outputs standard NMEA data messages through a UART interface.

Housed in a compact reflow-compatible SMD package, the receiver requires no programming or additional RF components (except an antenna) to form a complete GPS solution. This makes the RM Series easy to integrate, even by engineers without previous RF or GPS experience.

### Features

- MediaTek chipset
- High sensitivity (–161dBm)
- Fast TTFF at low signal levels
- ±11ns 1PPS accuracy
- Battery-backed SRAM
- No programming necessary
- No external RF components needed (except an antenna)
- No production tuning
- UART serial interface
- Power control features
- Compact SMD package

### Applications Include

- Positioning and Navigation
- Location and Tracking
- Security/Loss-Prevention
- Surveying
- Logistics
- Fleet Management

## Ordering Information

Ordering Information	
Part Number	Description
RXM-GPS-RM-x	RM Series GPS Receiver Module
MDEV-GPS-RM	RM Series GPS Receiver Master Development System
EVM-GPS-RM	RM Series Evaluation Module

x = "T" for Tape and Reel, "B" for Bulk  
 Reels are 1,500 pieces. Quantities less than 1,500 pieces are supplied in bulk

Figure 2: Ordering Information

## Absolute Maximum Ratings

Absolute Maximum Ratings		
Supply Voltage $V_{CC}$	+4.3	VDC
Input Battery Backup Voltage	+4.3	VDC
VCC_RF Output Current	50	mA
Operating Temperature	-40 to +85	°C
Storage Temperature	-40 to +85	°C

Exceeding any of the limits of this section may lead to permanent damage to the device. Furthermore, extended operation at these maximum ratings may reduce the life of this device.

Figure 3: Absolute Maximum Ratings

## Electrical Specifications

RM Series GPS Receiver Specifications						
Parameter	Symbol	Min.	Typ.	Max.	Units	Notes
Power Supply						
Operating Voltage	$V_{CC}$	3.0	3.3	4.3	VDC	
Supply Current	$I_{CC}$					
Peak				44	mA	1
Acquisition			14		mA	1
Tracking			12		mA	1
Standby			0.135		mA	1
Backup Battery Voltage	$V_{BAT}$	2.0		4.3	VDC	
Backup Battery Current	$I_{BAT}$		6		μA	2

RM Series GPS Receiver Specifications						
Parameter	Symbol	Min.	Typ.	Max.	Units	Notes
VOUT Output Voltage	$V_{OUT}$	2.7	2.8	2.9	VDC	
VOUT Output Current	$I_{OUT}$			30	mA	1
Output Low Voltage	$V_{OL}$			0.4	VDC	
Output High Voltage	$V_{OH}$	2.4		$V_{CC}$		
Output Low Current	$I_{OL}$		2.0		mA	
Output High Current	$I_{OH}$		2.0		mA	
Input Low Voltage	$V_{IL}$	-0.3		0.8	VDC	
Input High Voltage	$V_{IH}$	2.0		3.6	VDC	
Input Low Current	$I_{IL}$	-1		1	μA	3
Input High Current	$I_{IH}$	-1		1	μA	3
Minimum RESET Pulse	$T_{RST}$	1			ms	
Antenna Port						
RF Impedance	$R_{IN}$		50		Ω	
Receiver Section						
Receiver Sensitivity						
Tracking			-161		dBm	
Cold Start			-143		dBm	
Acquisition Time						
Hot Start (Open Sky)			1		s	
Hot Start (Indoor)			30		s	
Cold Start			32		s	
Position Accuracy						
Autonomous			3		m	
SBAS			2.5		m	
1PPS Accuracy		-11		11	ns	
Altitude				50,000	m	
Velocity				515	m/s	
Chipset	MediaTek MT3337					
Frequency	L1 1575.42MHz, C/A code					
Channels	22 tracking, 66 acquisition					
Update Rate	1Hz default, up to 10Hz					
Protocol Support	NMEA 0183 ver 3.01					

- $V_{CC} = 3.3V$ , without active antenna, position fix is available
- $V_{CC} = 0V$
- No pull-up or pull-down on the lines

Figure 4: Electrical Specifications

## Pin Assignments

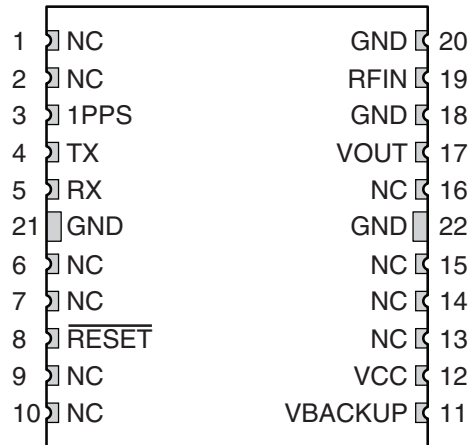

Figure 5: RM Series GPS Receiver Pinout (Top View)

## Pin Descriptions

Pin Descriptions			
Pin Number	Name	I/O	Description
1, 2, 6, 7, 9, 10, 13, 14, 15, 16	NC	-	No electrical connection
3	1PPS	O	1 Pulse Per Second
4	TX	O	Serial output (default NMEA)
5	RX	I	Serial input (default NMEA)
8	$\overline{\text{RESET}}$	I	Active low module reset. This line is pulled high internally. Leave it unconnected if it is not used.
11	VBACKUP	P	Backup battery supply voltage. This line must be powered to enable the module.
12	VCC	P	Supply Voltage
17	VOUT	O	2.8V output for an active antenna
18, 20, 21, 22	GND	P	Ground
19	RFIN	I	GPS RF signal input

Figure 6: RM Series GPS Receiver Pin Descriptions

## A Brief Overview of GPS

The Global Positioning System (GPS) is a U.S.-owned utility that freely and continuously provides positioning, navigation, and timing (PNT) information. Originally created by the U.S. Department of Defense for military applications, the system was made available without charge to civilians in the early 1980s. The global positioning system consists of a nominal constellation of 24 satellites orbiting the earth at about 12,000 nautical miles in height. The pattern and spacing of the satellites allow at least four to be visible above the horizon from any point on the Earth. Each satellite transmits low power radio signals which contain three different bits of information; a pseudorandom code identifying the satellite, ephemeris data which contains the current date and time as well as the satellite's health, and the almanac data which tells where each satellite should be at any time throughout the day.

A GPS receiver receives and times the signals sent by multiple satellites and calculates the distance to each satellite. If the position of each satellite is known, the receiver can use triangulation to determine its position anywhere on the earth. The receiver uses four satellites to solve for four unknowns; latitude, longitude, altitude and time. If any of these factors is already known to the system, an accurate position (fix) can be obtained with fewer satellites in view. Tracking more satellites improves calculation accuracy. In essence, the GPS system provides a unique address for every square meter on the planet.

A faster Time To First Fix (TTFF) is also possible if the satellite information is already stored in the receiver. If the receiver knows some of this information, then it can accurately predict its position before acquiring an updated position fix. For example, aircraft or marine navigation equipment may have other means of determining altitude, so the GPS receiver would only have to lock on to three satellites and calculate three equations to provide the first position fix after power-up.

## Time To First Fix (TTFF)

TTFF is often broken down into three parts.

**Cold:** A cold start is when the receiver has no accurate knowledge of its position or time. This happens when the receiver's internal Real Time Clock (RTC) has not been running or it has no valid ephemeris or almanac data. In a cold start, the receiver takes up to 30 seconds to acquire its position.

**Warm:** A typical warm start is when the receiver has valid almanac and time data and has not significantly moved since its last valid position calculation. This happens when the receiver has been shut down for more than 2 hours, but still has its last position, time, and almanac saved in memory, and its RTC has been running. The receiver can predict the location of the current visible satellites and its location; however, it needs to wait for an ephemeris broadcast (every 30 seconds) before it can accurately calculate its position.

**Hot:** A hot start is when the receiver has valid ephemeris, time, and almanac data. In a hot start, the receiver takes 1 second to acquire its position. The time to calculate a fix in this state is sometimes referred to as Time to Subsequent Fix or TTTF.

## Module Description

The RM Series GPS Receiver module is based on the MediaTek MT3337 chipset, which consumes less power than competitive products while providing exceptional performance even in dense foliage and urban canyons. No external RF components are needed other than an antenna. The simple serial interface and industry standard NMEA protocol make integration of the RM Series into an end product extremely straightforward.

The module's high-performance RF architecture allows it to receive GPS signals that are as low as  $-161\text{dBm}$ . The RM Series can track up to 22 satellites at the same time. Once locked onto the visible satellites, the receiver calculates the range to the satellites and determines its position and the precise time. It then outputs the data through a standard serial port using several standard NMEA protocol formats.

The GPS core handles all of the necessary initialization, tracking, and calculations autonomously, so no programming is required. The RF section is optimized for low level signals, and requires no production tuning.

## Backup Battery

The module is designed to work with a backup battery that keeps the SRAM memory and the RTC powered when the RF section and the main GPS core are powered down. This enables the module to have a faster Time To First Fix (TTFF) when it is powered back on. The memory and clock pull about  $6\mu\text{A}$ . This means that a small lithium battery is sufficient to power these sections. This significantly reduces the power consumption and extends the main battery life while allowing for fast position fixes when the module is powered back on.

The backup battery must be installed for the module to be enabled.

## Power Supply Requirements

The module requires a clean, well-regulated power source. While it is preferable to power the unit from a battery, it can operate from a power supply as long as noise is less than  $20\text{mV}$ . Power supply noise can significantly affect the receiver's sensitivity, therefore providing clean power to the module should be a high priority during design. Bypass capacitors should be placed as close as possible to the module. The values should be adjusted depending on the amount and type of noise present on the supply line.

## The 1PPS Output

The 1PPS line outputs 1 pulse per second on the rising edge of the GPS second when the receiver has an over-solved navigation solution from five or more satellites. The pulse has a duration of  $100\text{ms}$  with the rising edge on the GPS second. This line is low until the receiver acquires a 3D fix. The GPS second is based on the atomic clocks in the satellites, which are monitored and set to Universal Time master clocks. This output and the time calculated from the satellite transmissions can be used as a clock feature in an end product with  $\pm 11\text{ns}$  accuracy.

## Antenna Considerations

The RM Series module is designed to utilize a wide variety of external antennas. The module has a regulated power output which simplifies the use of GPS antenna styles which require external power. This allows the designer great flexibility, but care must be taken in antenna selection to ensure optimum performance. For example, a handheld device may be used in many varying orientations so an antenna element with a wide and uniform pattern may yield better overall performance than an antenna element with high gain and a correspondingly narrower beam. Conversely, an antenna mounted in a fixed and predictable manner may benefit from pattern and gain characteristics suited to that application. Evaluating multiple antenna solutions in real-world situations is a good way to rapidly assess which will best meet the needs of your application.

For GPS, the antenna should have good right hand circular polarization characteristics (RHCP) to match the polarization of the GPS signals. Ceramic patches are the most commonly used style of antenna, but there are many different shapes, sizes and styles of antennas available. Regardless of the construction, they will generally be either passive or active types. Passive antennas are simply an antenna tuned to the correct frequency. Active antennas add a Low Noise Amplifier (LNA) after the antenna and before the module to amplify the weak GPS satellite signals.

For active antennas, a 300 ohm ferrite bead can be used to connect the VOUT line to the RFIN line. This bead prevents the RF from getting into the power supply, but allows the DC voltage onto the RF trace to feed into the antenna. A series capacitor inside the module prevents this DC voltage from affecting the bias on the module's internal LNA.

Maintaining a 50 ohm path between the module and antenna is critical. Errors in layout can significantly impact the module's performance. Please review the layout guidelines section carefully to become more familiar with these considerations.

## Power Control

The RM Series GPS Receiver module offers several ways to control the module's power. A serial command puts the module into a low-power standby mode that consumes only 135 $\mu$ A of current. An external processor can be used to power the module on and off to conserve battery power.

In addition, the module includes a duty cycle mode where the module will power on for a configurable amount of time to obtain a position fix then power off for a configurable amount of time. In this way the module can handle all of the timing without any intervention from the external processor.

There are four times that are configured with duty cycle mode. The on time and standby times are the amount of times that the module is on and in standby in normal operation. There are also cold start on and standby times. These are used to keep the module on longer in the event of a cold start so that it can gather the required satellite data for a position fix. After this, the module uses the normal operation times.

In the event that the module's stored ephemeris data becomes invalid the module supports and extended receive time to gather the required data from the satellites. Figure 7 shows the power control times.

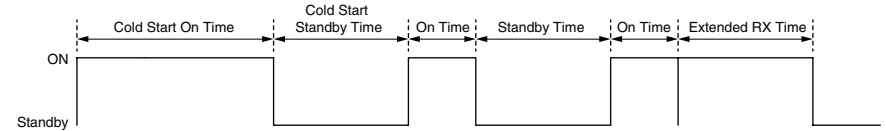

Figure 7: RM Series GPS Receiver Power Control

The module supports MediaTek's proprietary AlwaysLocate™ mode. In this mode, the module automatically adapts the on and standby times to the current environmental conditions to balance position accuracy and power consumption. In this mode, any byte sent to the module triggers it to output the current position data.

Standby mode is configured by command 161. Extended receive time is configured by command 223. Command 225 configures which duty cycle mode is used.

## Slow Start Time

The most critical factors in start time are current ephemeris data, signal strength and sky view. The ephemeris data describes the path of each satellite as they orbit the earth. This is used to calculate the position of a satellite at a particular time. This data is only usable for a short period of time, so if it has been more than a few hours since the last fix or if the location has significantly changed (a few hundred miles), then the receiver may need to wait for a new ephemeris transmission before a position can be calculated. The GPS satellites transmit the ephemeris data every 30 seconds. Transmissions with a low signal strength may not be received correctly or be corrupted by ambient noise. The view of the sky is important because the more satellites the receiver can see, the faster the fix and the more accurate the position will be when the fix is obtained.

If the receiver is in a very poor location, such as inside a building, urban canyon, or dense foliage, then the time to first fix can be slowed. In very poor locations with poor signal strength and a limited view of the sky with outdated ephemeris data, this could be on the order of several minutes. In the worst cases, the receiver may need to receive almanac data, which describes the health and course data for every satellite in the constellation. This data is transmitted every 15 minutes. If a lock is taking a long time, try to find a location with a better view of the sky and fewer obstructions. Once locked, it is easier for the receiver to maintain the position fix.

## Interfacing with NMEA Messages

Linux modules default to the NMEA protocol. Output messages are sent from the receiver on the TX line and input messages are sent to the receiver on the RX line. By default, output messages are sent once every second. Details of each message are described in the following sections.

The NMEA message format is as follows: <Message-ID + Data Payload + Checksum + End Sequence>. The serial data structure defaults to 9,600bps, 8 data bits, 1 stop bit, and no parity bits. Each message starts with a \$ character and ends with a <CR> <LF>. All fields within each message are separated by a comma. The checksum follows the \* character and is the last two characters, not including the <CR> <LF>. It consists of two hex digits representing the exclusive OR (XOR) of all characters between, but not including, the \$ and \* characters. When reading NMEA output messages, if a field has no value assigned to it, the comma will still be placed following the previous comma. For example, {,04,,,,,2.0,} shows four empty fields between values 04 and 2.0. When writing NMEA input messages, all fields are required, none are optional. An empty field will invalidate the message and it will be ignored.

Reading NMEA output messages:

- Initialize a serial interface to match the serial data structure of the GPS receiver.
- Read the NMEA data from the TX pin into a receive buffer.
- Separate it into six buffers, one for each message type. Use the characters (\$) and <CR> <LF> as end points for each message.
- For each message, calculate the checksum as mentioned above to compare with the received checksum.
- Parse the data from each message using commas as field separators.
- Update the application with the parsed field values.
- Clear the receive buffer and be ready for the next set of messages.

Writing NMEA input messages:

- Initialize a serial interface to match the serial data structure of the GPS receiver.
- Assemble the message to be sent with the calculated checksum.
- Transmit the message to the receiver on the RX line.



## NMEA Output Messages

The following sections outline the data structures of the various NMEA messages that are supported by the module. By default, the NMEA commands are output at 9,600bps, 8 data bits, no parity and 1 stop bit.

Four messages are output at a 1Hz rate by default; GGA, GSA, GSV and RMC. GLL and VTG can be enabled using the input messages. These messages are shown in Figure 8.

NMEA Output Messages	
Name	Description
GGA	Contains the essential fix data which provide location and accuracy
GLL	Contains just position and time
GSA	Contains data on the Dilution of Precision (DOP) and which satellites are used
GSV	Contains the satellite location relative to the receiver and its signal to noise ratio. Each message can describe 4 satellites so multiple messages may be output depending on the number of satellites being tracked.
RMC	Contains the minimum data of time, position, speed and course
VTG	Contains the course and speed over the ground

Figure 8: NMEA Output Messages

Details of each message and examples are given in the following sections.

## GGA – Global Positioning System Fix Data

Figure 9 contains the values for the following example:

`$GPGGA,053740.000,2503.6319,N,12136.0099,E,1,08,1.1,63.8,M,15.2,M,,0000*64`

Global Positioning System Fix Data Example			
Name	Example	Units	Description
Message ID	\$GPGGA		GGA protocol header
UTC Time	053740.000		hhmmss.sss
Latitude	2503.6319		ddmm.mmmm
N/S Indicator	N		N=north or S=south
Longitude	12136.0099		dddmm.mmmm
E/W Indicator	E		E=east or W=west
Position Fix Indicator	1		See Figure 11
Satellites Used	08		Range 0 to 33
HDOP	1.1		Horizontal Dilution of Precision
MSL Altitude	63.8	meters	
Units	M	meters	
Geoid Separation	15.2	meters	
Units	M	meters	
Age of Diff. Corr.		second	Null fields when DGPS is not used
Diff. Ref. Station	0000		
Checksum	*64		
<CR> <LF>			End of message termination

Figure 9: Global Positioning System Fix Data Example

Position Indicator Values	
Value	Description
0	Fix not available or invalid
1	GPS SPS Mode, fix valid
2	Differential GPS, SPS Mode, fix valid
3–5	Not supported
6	Dead Reckoning Mode, fix valid (requires external hardware)

Figure 10: Position Indicator Values

## GLL – Geographic Position – Latitude / Longitude

Figure 11 contains the values for the following example:

*\$GPGLL,2503.6319,N,12136.0099,E,053740.000,A,A\*52*

Geographic Position – Latitude / Longitude Example			
Name	Example	Units	Description
Message ID	\$GPGLL		GLL protocol header
Latitude	2503.6319		ddmm.mmmm
N/S Indicator	N		N=north or S=south
Longitude	12136.0099		dddmm.mmmm
E/W Indicator	E		E=east or W=west
UTC Time	053740.000		hhmmss.sss
Status	A		A=data valid or V=data not valid
Mode	A		A=autonomous, D=DGPS, N=Data not valid, R=Coarse Position, S=Simulator
Checksum	*52		
<CR> <LF>			End of message termination

Figure 11: Geographic Position – Latitude / Longitude Example

## GSA – GPS DOP and Active Satellites

Figure 12 contains the values for the following example:

*\$GPGSA,A,3,24,07,17,11,28,08,20,04,,,,,2.0,1.1,1.7\*35*

GPS DOP and Active Satellites Example			
Name	Example	Units	Description
Message ID	\$GPGSA		GSA protocol header
Mode 1	A		See Figure 14
Mode 2	3		1=No fix, 2=2D, 3=3D
ID of satellite used	24		Sv on Channel 1
ID of satellite used	07		Sv on Channel 2
...			...
ID of satellite used			Sv on Channel N
PDOP	2.0		Position Dilution of Precision
HDOP	1.1		Horizontal Dilution of Precision
VDOP	1.7		Vertical Dilution of Precision
Checksum	*35		
<CR> <LF>			End of message termination

Figure 12: GPS DOP and Active Satellites Example

## Mode 1 Values

Value	Description
M	Manual – forced to operate in 2D or 3D mode
A	Automatic – allowed to automatically switch 2D/3D

Figure 13: Mode 1 Values

## GSV – GPS Satellites in View

Figure 14 contains the values for the following example:

*\$GPGSV,3,1,12,28,81,285,42,24,67,302,46,31,54,354,,20,51,077,46\*73*

*\$GPGSV,3,2,12,17,41,328,45,07,32,315,45,04,31,250,40,11,25,046,41\*75*

*\$GPGSV,3,3,12,08,22,214,38,27,08,190,16,19,05,092,33,23,04,127,\*7B*

## GPS Satellites in View Example

Name	Example	Units	Description
Message ID	\$GPGSV		GSV protocol header
Total number of messages <sup>1</sup>	3		Range 1 to 4
Message number <sup>1</sup>	1		Range 1 to 4
Satellites in view	12		
Satellite ID	28		Channel 1 (Range 01 to 196)
Elevation	81	degrees	Channel 1 (Range 00 to 90)
Azimuth	285	degrees	Channel 1 (Range 000 to 359)
SNR (C/No)	42	dB-Hz	Channel 1 (Range 00 to 99, null when not tracking)
Satellite ID	20		Channel 2 (Range 01 to 196)
Elevation	51	degrees	Channel 2 (Range 00 to 90)
Azimuth	077	degrees	Channel 2 (Range 000 to 359)
SNR (C/No)	46	dB-Hz	Channel 2 (Range 00 to 99, null when not tracking).
Checksum	*73		
<CR> <LF>			End of message termination

1. Depending on the number of satellites tracked, multiple messages of GSV data may be required.

Figure 14: GPS Satellites in View Example

## RMC – Recommended Minimum Specific GPS Data

Figure 15 contains the values for the following example:

```
$GPRMC,053740.000,A,2503.6319,N,12136.0099,E,2.69,79.65,100106,,,A*53
```

Recommended Minimum Specific GPS Data Example			
Name	Example	Units	Description
Message ID	\$GPRMC		RMC protocol header
UTC Time	053740.000		hhmmss.sss
Status	A		A=data valid or V=data not valid
Latitude	2503.6319		ddmm.mmmm
N/S Indicator	N		N=north or S=south
Longitude	12136.0099		dddmm.mmmm
E/W Indicator	E		E=east or W=west
Speed over ground	2.69	knots	TRUE
Course over ground	79.65	degrees	
Date	100106		ddmmyy
Magnetic Variation		degrees	Not available, null field
Variation Sense			E=east or W=west (not shown)
Mode	A		A=autonomous, D=DGPS, E=DR, N=Data not valid, R=Coarse Position, S=Simulator
Checksum	*53		
<CR> <LF>			End of message termination

Figure 15: Recommended Minimum Specific GPS Data Example

## VTG – Course Over Ground and Ground Speed

Figure 16 contains the values for the following example:

```
$GPVTG,79.65,T,,M,2.69,N,5.0,K,A*38
```

Course Over Ground and Ground Speed Example			
Name	Example	Units	Description
Message ID	\$GPVTG		VTG protocol header
Course over ground	79.65	degrees	Measured heading
Reference	T		TRUE
Course over ground		degrees	Measured heading (N/A, null field)
Reference	M		Magnetic
Speed over ground	2.69	knots	Measured speed
Units	N		Knots
Speed over ground	5.0	km/hr	Measured speed
Units	K		Kilometer per hour
Mode	A		A=autonomous, D=DGPS, N=Data not valid, R=Coarse Position, S=Simulator
Checksum	*38		
<CR> <LF>			End of message termination

Figure 16: Course Over Ground and Ground Speed Example

## Start-up Response

The module outputs a message when it starts up to indicate its state. The normal start-up message is shown below and the message formatting is shown in Figure 17.

```
$PMTK010,001*2E<CR><LF>
```

Start-up Response Example		
Name	Example	Description
Message ID	\$PMTK010	Message header
Message	MSG	System Message 0 = Unknown 1 = Start-up 2 = Notification for the host supporting EPO 3 = Transition to Normal operation is successful
Checksum	CKSUM	
End Sequence	<CR> <LF>	End of message termination

Figure 17: Start-up Response Example

## Input Messages

The following outlines the serial commands input into the module for configuration. There are 3 types of input messages: commands, writes and reads. The module outputs a response for each input message.

The commands are used to change the operating state of the module. The writes are used to change the module's configuration and the reads are used to read out the current configuration. Messages are formatted as shown in Figure 18. All fields in each message are separated by a comma.

Serial Data Structure		
Name	Example	Description
Start Sequence	\$PMTK	
Message ID	<MID>	Message Identifier consisting of three numeric characters.
Payload	DATA	Message specific data.
Checksum	CKSUM	CKSUM is a two-hex character checksum as defined in the NMEA specification, NMEA-0183 Standard for Interfacing Marine Electronic Devices. Checksums are required on all input messages.
End Sequence	<CR> <LF>	Each message must be terminated using Carriage Return (CR) Line Feed (LF) (\r\n, 0x0D0A) to cause the receiver to process the input message. They are not printable ASCII characters, so are omitted from the examples.

Figure 18: Serial Data Structure

Figure 19 shows the input commands.

Input Commands	
Name	Description
101	Hot Re-start
102	Warm Re-start
103	Cold Re-start
104	Restore Default Configuration
161	Standby Mode
220	Position Fix Interval
223	Ephemeris Data Receive Time
225	Receiver Duty Cycle
251	Baud Rate

Figure 19: Input Commands

The write and read messages are shown in Figure 20. A write message triggers an acknowledgement from the module. A read message triggers a response message containing the requested information.

Input Write and Read Messages			
Description	Write ID	Read ID	Response ID
Position Fix Interval	300	400	500
DGPS Source	301	401	501
SBAS Enable	313	413	513
NMEA Output Messages	314	414	514
Set Datum	330	430	530
Static Navigation Threshold	386	447	527

Figure 20: Input Write and Read Messages

The module responds to commands with response messages. The acknowledge message is formatted as shown in Figure 21.

Acknowledge Message		
Name	Example	Description
Start Sequence	\$PMTK	
Message ID	001	Acknowledge Identifier
Command	CMD	The command that triggered the acknowledge
Flag	Fig	Flag indicating the outcome of the command 0 = Invalid Command 1 = Unsupported Command 2 = Valid command, but action failed 3 = Valid command and action succeeded
Checksum	CKSUM	CKSUM is a two-hex character checksum as defined in the NMEA specification, NMEA-0183 Standard for Interfacing Marine Electronic Devices. Checksums are required on all input messages.
End Sequence	<CR> <LF>	Each message must be terminated using Carriage Return (CR) Line Feed (LF) (\r\n, 0x0D0A) to cause the receiver to process the input message. They are not printable ASCII characters, so are omitted from the examples.

Figure 21: Acknowledge Message

### 101 – Hot Re-start

This command instructs the module to conduct a hot re-start using all of the data stored in memory. Periodic mode and static navigation settings are returned to default when this command is executed.

```
$PMTK101*32<CR><LF>
```

### 102 – Warm Re-start

This command instructs the module to conduct a warm re-start that does not use the saved ephemeris data. Periodic mode and static navigation settings are returned to default when this command is executed.

```
$PMTK102*31<CR><LF>
```

### 103 – Cold Re-start

This command instructs the module to conduct a cold re-start that does not use any of the data from memory. Periodic mode and static navigation settings are returned to default when this command is executed.

```
$PMTK103*30<CR><LF>
```

### 104 – Restore Default Configuration

This command instructs the module to conduct a cold re-start and return all configurations to the factory default settings.

```
$PMTK104*37<CR><LF>
```

### 161 – Standby Mode

This command instructs the module to enter a low power standby mode. Any activity on the RX line wakes the module.

```
$PMTK161,0*28<CR><LF>
```

The module outputs the startup message when it wakes up.

```
$PMTK010,001*2E<CR><LF>
```

### 220 – Position Fix Interval

This command sets the position fix interval. This is the time between when the module calculates its position. This is the same as write message 300.

#### Position Fix Interval Command and Response

##### Command

Start	Msg ID	Interval	Checksum	End
\$PMTK	220	,lval	*Cksum	<CR><LF>

##### Response

Start	Msg ID	CMD	Flag	Checksum	End
\$PMTK	001	,220	,Flg	*Cksum	<CR><LF>

Figure 22: Position Fix Interval Command and Response

lval = the interval time in milliseconds.

The interval must be larger than 100ms. Faster rates require that the baud rate be increased, the number of messages that are output be decreased or both. The module automatically calculates the required data bandwidth and returns an action failed response (Flg = 2) if the interval is faster than the module can output all of the required messages at the current baud rate. The following example sets the interval to 1 second.

```
$PMTK220,1000*1F<CR><LF>
```

## 223 – Extended Receive Time

This command extends the amount of time that the receiver is on when in duty cycle mode. This allows the module to refresh its stored ephemeris data by staying awake until it received the data from the satellites.

Extended Receive Time Command and Response							
Command							
Start	Msg ID	SV	On Time	Extend Time	Extend Gap	Checksum	End
\$PMTK	223	,SV	,SNR	,EXT	,EXG	*Cksum	<CR><LF>
Response							
Start	Msg ID	CMD	Flag	Checksum	End		
\$PMTK	001	,223	,Flg	*Cksum	<CR><LF>		

Figure 23: Extended Receive Time Command and Response

Extended Receive Time Fields	
Field	Description
SV	The minimum number of satellites required to have valid ephemeris data. The extend time triggers when the number of satellites with valid ephemeris data falls below this number. The value is 1 to 4.
SNR	The minimum SNR of the satellites used for a position fix. The module will not wait for ephemeris data from any satellites whose SNR is below this value.
EXT	The extended time in ms to stay on to receive ephemeris data. This value can range from 40000 to 180000.
EXG	The minimum time in ms between a subsequent extended receive period. This value can range from 0 to 3600000.

Figure 24: Extended Receive Time Fields

The following example configures an extended on time to trigger if less than 1 satellite has valid ephemeris data. The satellite must have a signal to noise ratio higher than 30dB-Hz in order to be used. The module will stay on for 180,000ms and will have a gap time of 60,000ms.

```
$PMTK223,1,30,180000,60000*16<CR><LF>
```

## 225 – Receiver Duty Cycle

This command places the module into a duty cycle where it stays on for a period of time and calculates its position then goes to sleep for a period of time. This conserves battery power without the need for an external microcontroller to manage the timing.

Receiver Duty Cycle Command and Response									
Command									
Start	Msg ID	Mode	On Time	Standby Time	Cold On	Cold Sleep	Checksum	End	
\$PMTK	225	,Mde	,TO	,TS	,CO	,CS	*Cksum	<CR><LF>	
Response									
Start	Msg ID	CMD	Flag	Checksum	End				
\$PMTK	001	,225	,Flg	*Cksum	<CR><LF>				

Figure 25: Receiver Duty Cycle Command and Response

Receiver Duty Cycle Fields	
Field	Description
Mde	Operation Mode 0 = Normal Mode 2 = Duty Cycle Mode 8 = AlwaysLocate™
TO	Receiver on time (ms)
TS	Receiver standby time (ms)
CO	Receiver on time in the event of a cold start (ms). Allows more time for the module to receive ephemeris data in the event of a cold start.
CS	Receiver off time in the event of a cold start (ms). Allows more time for the module to receive ephemeris data in the event of a cold start.

CR and CS can be null values. In this case the module uses the TO and TS values.

Figure 26: Receiver Duty Cycle Fields

This example sets the mode to duty cycle with an on time of 3s, and off time of 12s, a cold start on time of 18s and a cold start off time of 72s.

```
$PMTK225,2,3000,12000,18000,72000*15<CR><LF>
```

The following example sets the mode to normal operation.

```
$PMTK225,0*2B<CR><LF>
```

The following example sets the module into AlwaysLocate™ mode.

```
$PMTK225,8*23<CR><LF>
```

## 251 – Baud Rate

This command sets the serial port baud rate.

Serial Port Baud Rate Command and Response					
<b>Command</b>					
Start	Msg ID	Rate	Checksum	End	
\$PMTK	251	,Rate	*Cksum	<CR><LF>	
<b>Response</b>					
Start	Msg ID	CMD	Flag	Checksum	End
\$PMTK	001	,251	,Flg	*Cksum	<CR><LF>

Figure 27: Serial Port Baud Rate Command and Response

Rate = serial port baud rate

0 = default setting (9,600bps)

4800

9600

14400

19200

38400

57600

115200

The following example sets the baud rate to 57,600bps.

```
$PMTK251,57600*2C<CR><LF>
```

## Position Fix Interval

This configures the position fix interval. This is the time between when the module calculates its position. This is the same as write message 220.

Position Fix Interval Command and Response					
<b>Write Message</b>					
Start	Msg ID	Interval	Data	Checksum	End
\$PMTK	300	,lval	,0,0,0,0	*Cksum	<CR><LF>
<b>Acknowledge Response Message</b>					
Start	Msg ID	CMD	Flag	Checksum	End
\$PMTK	001	,300	,Flg	*Cksum	<CR><LF>
<b>Read Message</b>					
Start	Msg ID	Checksum	End		
\$PMTK	400	*36	<CR><LF>		
<b>Response Message</b>					
Start	Msg ID	Interval	Data	Checksum	End
\$PMTK	500	,lval	,0,0,0,0	*Cksum	<CR><LF>

Figure 28: Position Fix Interval Command and Response

lval = the interval time in milliseconds.

The interval must be larger than 100ms. Faster rates require that the baud rate be increased, the number of messages that are output be decreased or both. The module automatically calculates the required data bandwidth and returns an action failed response (Flg = 2) if the interval is faster than the module can output all of the required messages at the current baud rate.

The following example sets the interval to 1 second.

```
$PMTK300,1000,0,0,0,0*1C<CR><LF>
```

The following example reads the current position fix interval and the module responds with an interval time of 1 second (1,000ms)

```
$PMTK400*36<CR><LF>
```

```
$PMTK500,1000,0,0,0,0*1A<CR><LF>
```

## DGPS Source

This enables or disables DGPS mode and configures its source.

DGPS Source Command and Response					
<b>Write Message</b>					
Start	Msg ID	Mode	Checksum	End	
\$PMTK	301	,Mode	*Cksum	<CR><LF>	
<b>Acknowledge Response Message</b>					
Start	Msg ID	CMD	Flag	Checksum	End
\$PMTK	001	,301	,Flg	*Cksum	<CR><LF>
<b>Read Message</b>					
Start	Msg ID	Checksum	End		
\$PMTK	401	*37	<CR><LF>		
<b>Response Message</b>					
Start	Msg ID	Mode	Checksum	End	
\$PMTK	501	,Mode	*Cksum	<CR><LF>	

Figure 29: DGPS Source Command and Response

Mode = DGPS source mode

- 0 = No DGPS source
- 1 = RTCM
- 2 = WAAS

Differential Global Positioning System (DGPS) enhances GPS by using fixed, ground-based reference stations that broadcast the difference between the positions indicated by the satellite systems and the known fixed positions. The Radio Technical Commission for Maritime Services (RTCM) is an international standards organization that has a standard for DGPS. Wide Area Augmentation System (WAAS) is maintained by the FAA to improve aircraft navigation. This setting automatically switches among WAAS, EGNOS, MSAS and GAGAN when detected in covered regions

The following example sets the DGPS source to RTCM.

```
$PMTK301,1*2D<CR><LF>
```

The following example reads the current DGPS source and the module responds with the DGPS source as RTCM.

```
$PMTK401*37<CR><LF>  
$PMTK501,1*2B<CR><LF>
```

## SBAS Enable

This enables and disables SBAS.

SBAS Enable Command and Response					
<b>Write Message</b>					
Start	Msg ID	Mode	Checksum	End	
\$PMTK	313	,Mode	*Cksum	<CR><LF>	
<b>Acknowledge Response Message</b>					
Start	Msg ID	CMD	Flag	Checksum	End
\$PMTK	001	,313	,Flg	*Cksum	<CR><LF>
<b>Read Message</b>					
Start	Msg ID	Checksum	End		
\$PMTK	413	*34	<CR><LF>		
<b>Response Message</b>					
Start	Msg ID	Mode	Checksum	End	
\$PMTK	513	,Mode	*Cksum	<CR><LF>	

Figure 30: SBAS Enable Command and Response

Mode = SBAS Mode

- 0 = disabled
- 1 = enabled

A satellite-based augmentation system (SBAS) sends additional information in the satellite transmissions to improve accuracy and reliability. Ground stations at accurately surveyed locations measure the satellite signals or other environmental factors that may impact the signal received by users. Correction information is then sent to the satellites and broadcast to the users. Disabling this feature also disables automatic DGPS.

The following example enables SBAS.

```
$PMTK313,1*2E<CR><LF>
```

The following example reads the current SBAS configuration and the module responds with SBAS is enabled.

```
$PMTK413*34<CR><LF>  
$PMTK513,1*28<CR><LF>
```





## Static Navigation Threshold

This configures the speed threshold to trigger static navigation. If the measured speed is below the threshold then the module holds the current position and sets the speed to zero.

Static Navigation Threshold Command and Response					
<b>Write Message</b>					
Start	Msg ID	Thold	Checksum	End	
\$PMTK	386	,Thold	*Cksum	<CR><LF>	
<b>Acknowledge Response Message</b>					
Start	Msg ID	CMD	Flag	Checksum	End
\$PMTK	001	,386	,Flg	*Cksum	<CR><LF>
<b>Read Message</b>					
Start	Msg ID	Checksum	End		
\$PMTK	447	*35	<CR><LF>		
<b>Response Message</b>					
Start	Msg ID	Thold	Checksum	End	
\$PMTK	527	,Thold	*Cksum	<CR><LF>	

Figure 33: Static Navigation Threshold Command and Response

Static navigation is disabled by default, and is set for walking speed.

Thold = speed threshold, from 0 to 2.0m/s. 0 = disabled.

The following example sets the threshold to 1.2m/s.

```
$PMTK386,1.2*3E<CR><LF>
```

The following example reads the static navigation threshold and the module responds with 1.2m/s

```
$PMTK447*35<CR><LF>
$PMTK527,1.20*03<CR><LF>
```

## Typical Applications

Figure 34 shows the RM Series GPS receiver in a typical application using a passive antenna.

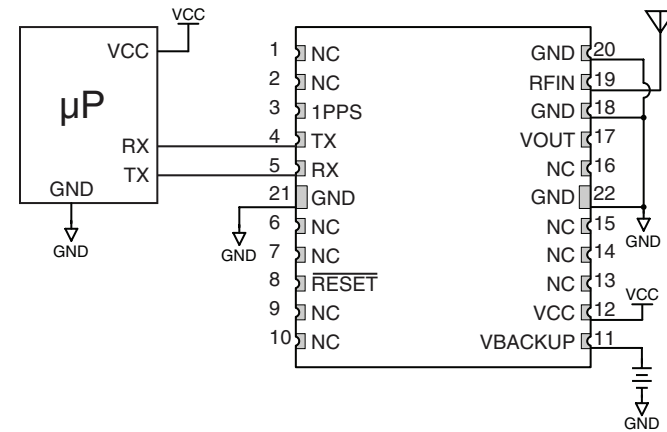

Figure 34: Circuit Using the RM Series Module with a Passive Antenna

A microcontroller UART is connected to the receiver's UART for passing data and commands. A 3.3V coin cell battery is connected to the VBACKUP line to provide power to the module's memory when main power is turned off.

Figure 35 shows the module using an active antenna.

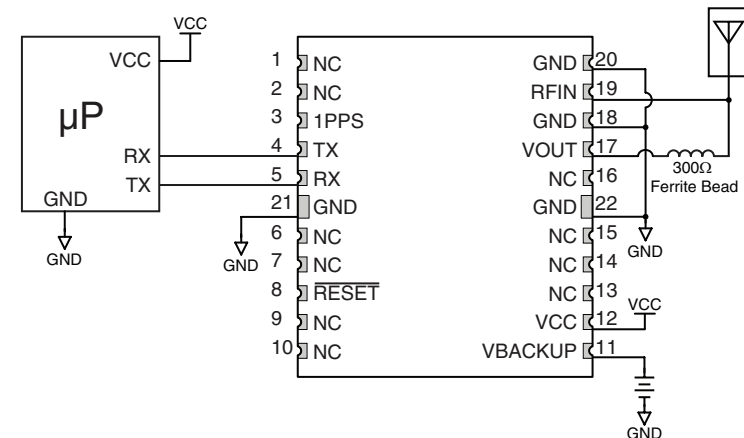

Figure 35: Circuit Using the RM Series Module with an Active Antenna

A 300Ω ferrite bead is used to put power from VOUT onto the antenna line to power the active antenna.

## Master Development System

The RM Series Master Development System provides all of the tools necessary to evaluate the RM Series GPS receiver module. The system includes a fully assembled development board, an active antenna, development software and full documentation.



Figure 36: The RM Series Master Development System

The development board includes a power supply, a prototyping area for custom circuit development, and an OLED display that shows the GPS data without the need for a computer. A USB interface is also included for use with a PC running custom software or the included development software.



Figure 37: The Master Development System Software

The Master Development System software enables configuration of the receiver and displays the satellite data output by the receiver. The software can select from among all of the supported NMEA protocols for display of the data.

Full documentation for the board and software is included in the development system, making integration of the module straightforward.

## Microstrip Details

A transmission line is a medium whereby RF energy is transferred from one place to another with minimal loss. This is a critical factor, especially in high-frequency products like Linx RF modules, because the trace leading to the module's antenna can effectively contribute to the length of the antenna, changing its resonant bandwidth. In order to minimize loss and detuning, some form of transmission line between the antenna and the module should be used unless the antenna can be placed very close (<1/8in) to the module. One common form of transmission line is a coax cable and another is the microstrip. This term refers to a PCB trace running over a ground plane that is designed to serve as a transmission line between the module and the antenna. The width is based on the desired characteristic impedance of the line, the thickness of the PCB and the dielectric constant of the board material. For standard 0.062in thick FR-4 board material, the trace width would be 111 mils. The correct trace width can be calculated for other widths and materials using the information in Figure 38 and examples are provided in Figure 39. Software for calculating microstrip lines is also available on the Linx website.

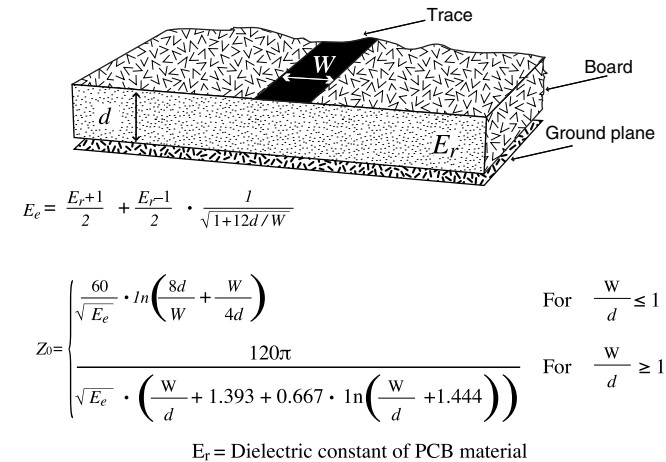

Figure 38: Microstrip Formulas

Example Microstrip Calculations			
Dielectric Constant	Width/Height Ratio (W/d)	Effective Dielectric Constant	Characteristic Impedance ( $\Omega$ )
4.80	1.8	3.59	50.0
4.00	2.0	3.07	51.0
2.55	3.0	2.12	48.0

Figure 39: Example Microstrip Calculations

## Board Layout Guidelines

The module's design makes integration straightforward; however, it is still critical to exercise care in PCB layout. Failure to observe good layout techniques can result in a significant degradation of the module's performance. A primary layout goal is to maintain a characteristic 50-ohm impedance throughout the path from the antenna to the module. Grounding, filtering, decoupling, routing and PCB stack-up are also important considerations for any RF design. The following section provides some basic design guidelines which may be helpful.

During prototyping, the module should be soldered to a properly laid-out circuit board. The use of prototyping or "perf" boards will result in poor performance and is strongly discouraged.

The module should, as much as reasonably possible, be isolated from other components on your PCB, especially high-frequency circuitry such as crystal oscillators, switching power supplies, and high-speed bus lines.

When possible, separate RF and digital circuits into different PCB regions. Make sure internal wiring is routed away from the module and antenna, and is secured to prevent displacement.

Do not route PCB traces directly under the module. There should not be any copper or traces under the module on the same layer as the module, just bare PCB. The underside of the module has traces and vias that could short or couple to traces on the product's circuit board.

The Pad Layout section shows a typical PCB footprint for the module. A ground plane (as large and uninterrupted as possible) should be placed on a lower layer of your PC board opposite the module. This plane is essential for creating a low impedance return for ground and consistent stripline performance.

Use care in routing the RF trace between the module and the antenna or connector. Keep the trace as short as possible. Do not pass under the module or any other component. Do not route the antenna trace on multiple PCB layers as vias will add inductance. Vias are acceptable for tying together ground layers and component grounds and should be used in multiples.

Each of the module's ground pins should have short traces tying immediately to the ground plane through a via.

Bypass caps should be low ESR ceramic types and located directly adjacent to the pin they are serving.

A 50-ohm coax should be used for connection to an external antenna. A 50-ohm transmission line, such as a microstrip, stripline or coplanar waveguide should be used for routing RF on the PCB. The Microstrip Details section provides additional information.

In some instances, a designer may wish to encapsulate or "pot" the product. There is a wide variety of potting compounds with varying dielectric properties. Since such compounds can considerably impact RF performance and the ability to rework or service the product, it is the responsibility of the designer to evaluate and qualify the impact and suitability of such materials.

## Pad Layout

The pad layout diagram in Figure 40 is designed to facilitate both hand and automated assembly.

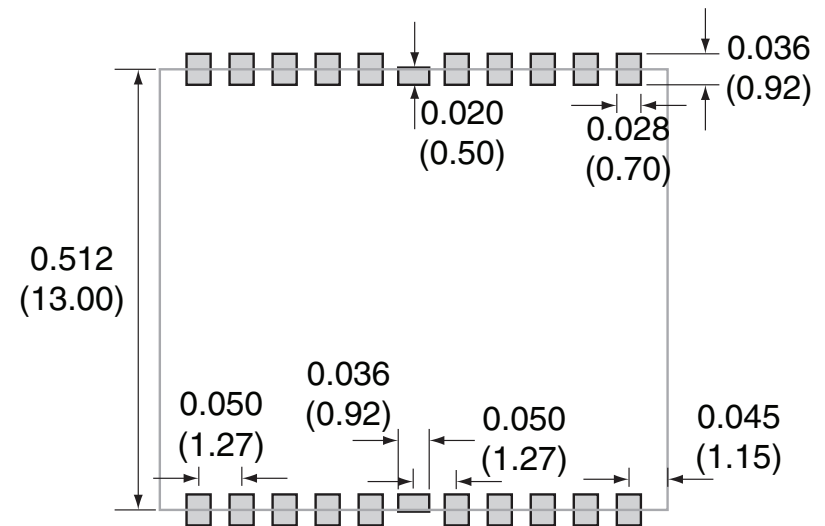

Figure 40: Recommended PCB Layout

## Production Guidelines

The module is housed in a hybrid SMD package that supports hand and automated assembly techniques. Since the modules contain discrete components internally, the assembly procedures are critical to ensuring the reliable function of the modules. The following procedures should be reviewed with and practiced by all assembly personnel.

## Hand Assembly

Pads located on the bottom of the module are the primary mounting surface (Figure 41). Since these pads are inaccessible during mounting, castellations that run up the side of the module have been provided to facilitate solder wicking to the module's underside. This allows for very

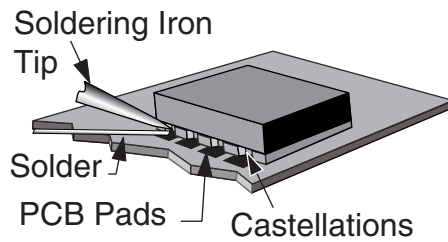

Figure 41: Soldering Technique

quick hand soldering for prototyping and small volume production. If the recommended pad guidelines have been followed, the pads will protrude slightly past the edge of the module. Use a fine soldering tip to heat the board pad and the castellation, then introduce solder to the pad at the module's edge. The solder will wick underneath the module, providing reliable attachment. Tack one module corner first and then work around the device, taking care not to exceed the times in Figure 42.

**Warning:** Pay attention to the absolute maximum solder times.

### Absolute Maximum Solder Times

Hand Solder Temperature: +427°C for 10 seconds for lead-free alloys

Reflow Oven: +240°C max (see Figure 43)

Figure 42: Absolute Maximum Solder Times

## Automated Assembly

For high-volume assembly, the modules are generally auto-placed. The modules have been designed to maintain compatibility with reflow processing techniques; however, due to their hybrid nature, certain aspects of the assembly process are far more critical than for other component types. Following are brief discussions of the three primary areas where caution must be observed.

## Reflow Temperature Profile

The single most critical stage in the automated assembly process is the reflow stage. The reflow profile in Figure 43 should not be exceeded because excessive temperatures or transport times during reflow will irreparably damage the modules. Assembly personnel need to pay careful attention to the oven's profile to ensure that it meets the requirements necessary to successfully reflow all components while still remaining within the limits mandated by the modules. The figure below shows the recommended reflow oven profile for the modules.

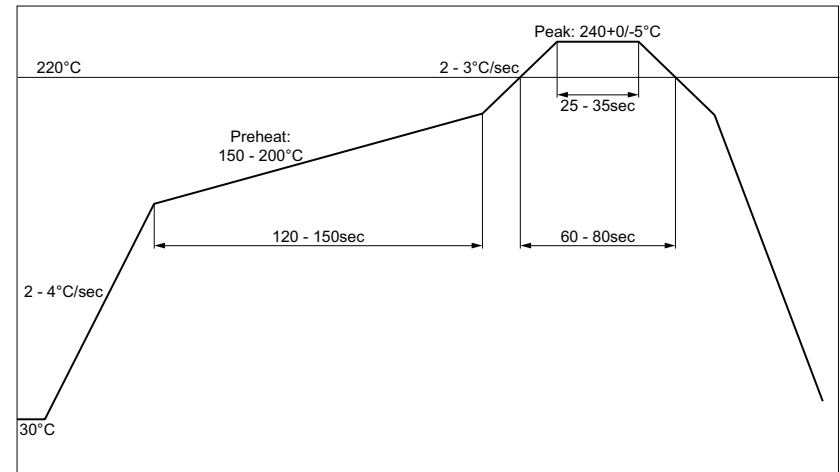

Figure 43: Maximum Reflow Temperature Profile

## Shock During Reflow Transport

Since some internal module components may reflow along with the components placed on the board being assembled, it is imperative that the modules not be subjected to shock or vibration during the time solder is liquid. Should a shock be applied, some internal components could be lifted from their pads, causing the module to not function properly.

## Washability

The modules are wash-resistant, but are not hermetically sealed. Linx recommends wash-free manufacturing; however, the modules can be subjected to a wash cycle provided that a drying time is allowed prior to applying electrical power to the modules. The drying time should be sufficient to allow any moisture that may have migrated into the module to evaporate, thus eliminating the potential for shorting damage during power-up or testing. If the wash contains contaminants, the performance may be adversely affected, even after drying.

## Appendix A

The following datums are supported by the RM Series.

RM Series GPS Receiver Supported Datums		
Number	Datum	Region
0	WGS1984	International
1	Tokyo	Japan
2	Tokyo	Mean for Japan, South Korea, Okinawa
3	User Setting	User Setting
4	Adindan	Burkina Faso
5	Adindan	Cameroon
6	Adindan	Ethiopia
7	Adindan	Mali
8	Adindan	Mean for Ethiopia, Sudan
9	Adindan	Senegal
10	Adindan	Sudan
11	Afgooye	Somalia
12	Ain El Abd1970	Bahrain
13	Ain El Abd1970	Saudi Arabia
14	American Samoa1962	American Samoa Islands
15	Anna 1 Astro1965	Cocos Island
16	Antigua Island Astro1943	Antigua(Leeward Islands)
17	Arc1950	Botswana
18	Arc1950	Burundi
19	Arc1950	Lesotho
20	Arc1950	Malawi
21	Arc1950	Mean for Botswana, Lesotho, Malawi, Swaziland, Zaire, Zambia, Zimbabwe
22	Arc1950	Swaziland
23	Arc1950	Zaire
24	Arc1950	Zambia
25	Arc1950	Zimbabwe
26	Arc1960	Mean For Kenya Tanzania
27	Arc1960	Kenya
28	Arc1960	Tanzania
29	Ascension Island1958	Ascension Island
30	Astro Beacon E 1945	Iwo Jima

RM Series GPS Receiver Supported Datums		
Number	Datum	Region
31	Astro Dos 71/4	St Helena Island
32	Astro Tern Island (FRIG) 1961	Tern Island
33	Astronomical Station 1952	Marcus Island
34	Australian Geodetic 1966	Australia, Tasmania
35	Australian Geodetic 1984	Australia, Tasmania
36	Ayabelle Lighthouse	Djibouti
37	Bellevue (IGN)	Efate and Erromango Islands
38	Bermuda 1957	Bermuda
39	Bissau	Guinea-Bissau
40	Bogota Observatory	Colombia
41	Bukit Rimpah	Indonesia (Bangka and Belitung Ids)
42	Camp Area Astro	Antarctica (McMurdi Camp Area)
43	Campo Inchauspe	Argentina
44	Canton Astro1966	Phoenix Island
45	Cape	South Africa
46	Cape Canaveral	Bahamas, Florida
47	Carthage	Tunisia
48	Chatham Island Astro1971	New Zealand (Chatham Island)
49	Chua Astro	Paraguay
50	Corrego Alegre	Brazil
51	Dabola	Guinea
52	Deception Island	Deception Island, Antarctica
53	Djakarta (Batavia)	Indonesia (Sumatra)
54	Dos 1968	New Georgia Islands (Gizo Island)
55	Easter Island 1967	Easter Island
56	Estonia Coordinate System1937	Estonia
57	European 1950	Cyprus
58	European 1950	Egypt
59	European 1950	England, Channel Islands, Scotland, Shetland Islands
60	European 1950	England, Ireland, Scotland, Shetland Islands
61	European 1950	Finland, Norway
62	European 1950	Greece
63	European 1950	Iran

**RM Series GPS Receiver Supported Datums**

Number	Datum	Region
64	European 1950	Italy (Sardinia)
65	European 1950	Italy (Sicily)
66	European 1950	Malta
67	European 1950	Mean For Austria, Belgium, Denmark, Finland, France, W Germany, Gibraltar, Greece, Italy, Luxembourg, Netherlands, Norway, Portugal, Spain, Sweden, Switzerland
68	European 1950	Mean For Austria, Denmark, France, W Germany, Netherland, Switzerland
69	European 1950	Mean For Iraq, Israel, Jordan, Lebanon, Kuwait, Saudi Arabia, Syria
70	European 1950	Portugal, Spain
71	European 1950	Tunisia,
72	European 1979	Mean For Austria, Finland ,Netherlands ,Norway, Spain, Sweden, Switzerland
73	Fort Thomas 1955	Nevis St Kitts (Leeward Islands)
74	Gan 1970	Republic Of Maldives
75	Geodetic Datum 1970	New Zealand
76	Graciosa Base SW1948	Azores (Faial, Graciosa, Pico, Sao, Jorge, Terceira)
77	Guam1963	Guam
78	Gunung Segara	Indonesia (Kalimantan)
79	Gux I Astro	Guadalcanal Island
80	Herat North	Afghanistan
81	Hermannskogel Datum	Croatia-Serbia, Bosnia-Herzegovina
82	Hjorsey 1955	Iceland
83	Hongkong 1963	Hong Kong
84	Hu Tzu Shan	Taiwan
85	Indian	Bangladesh
86	Indian	India, Nepal
87	Indian	Pakistan
88	Indian 1954	Thailand
89	Indian 1960	Vietnam (Con Son Island)
90	Indian 1960	Vietnam (Near 16 deg N)
91	Indian 1975	Thailand
92	Indonesian 1974	Indonesian

**RM Series GPS Receiver Supported Datums**

Number	Datum	Region
93	Ireland 1965	Ireland
94	ISTS 061 Astro 1968	South Georgia Islands
95	ISTS 073 Astro 1969	Diego Garcia
96	Johnston Island 1961	Johnston Island
97	Kandawala	Sri Lanka
98	Kerguelen Island 1949	Kerguelen Island
99	Kertau 1948	West Malaysia and Singapore
100	Kusaie Astro 1951	Caroline Islands
101	Korean Geodetic System	South Korea
102	LC5 Astro 1961	Cayman Brac Island
103	Leigon	Ghana
104	Liberia 1964	Liberia
105	Luzon	Philippines (Excluding Mindanao)
106	Luzon	Philippines (Mindanao)
107	M'Poraloko	Gabon
108	Mahe 1971	Mahe Island
109	Massawa	Ethiopia (Eritrea)
110	Merchich	Morocco
111	Midway Astro 1961	Midway Islands
112	Minna	Cameroon
113	Minna	Nigeria
114	Montserrat Island Astro 1958	Montserrat (Leeward Island)
115	Nahrwan	Oman (Masirah Island)
116	Nahrwan	Saudi Arabia
117	Nahrwan	United Arab Emirates
118	Naparima BWI	Trinidad and Tobago
119	North American 1927	Alaska (Excluding Aleutian Ids)
120	North American 1927	Alaska (Aleutian Ids East of 180 degW)
121	North American 1927	Alaska (Aleutian Ids West of 180 degW)
122	North American 1927	Bahamas (Except San Salvador Islands)
123	North American 1927	Bahamas (San Salvador Islands)
124	North American 1927	Canada (Alberta, British Columbia)
125	North American 1927	Canada (Manitoba, Ontario)

RM Series GPS Receiver Supported Datums		
Number	Datum	Region
126	North American 1927	Canada (New Brunswick, Newfoundland, Nova Scotia, Quebec)
127	North American 1927	Canada (Northwest Territories, Saskatchewan)
128	North American 1927	Canada (Yukon)
129	North American 1927	Canal Zone
130	North American 1927	Cuba
131	North American 1927	Greenland (Hayes Peninsula)
132	North American 1927	Mean For Antigua, Barbados, Barbuda, Caicos Islands, Cuba, Dominican, Grand Cayman, Jamaica, Turks Islands
133	North American 1927	Mean for Belize, Costa Rica, El Salvador, Guatemala, Honduras, Nicaragua
134	North American 1927	Mean for Canada
135	North American 1927	Mean for Conus
136	North American 1927	Mean for Conus (East of Mississippi, River Including Louisiana, Missouri, Minnesota)
137	North American 1927	Mean for Conus (West of Mississippi, River Excluding Louisiana, Minnesota, Missouri)
138	North American 1927	Mexico
139	North American 1983	Alaska (Excluding Aleutian Ids)
140	North American 1983	Aleutian Ids
141	North American 1983	Canada
142	North American 1983	Conus
143	North American 1983	Hawaii
144	North American 1983	Mexico, Central America
145	North Sahara 1959	Algeria
146	Observatorio Meteorologico 1939	Azores (Corvo and Flores Islands)
147	Old Egyptian 1907	Egypt
148	Old Hawaiian	Hawaii
149	Old Hawaiian	Kauai
150	Old Hawaiian	Maui
151	Old Hawaiian	Mean for Hawaii, Kauai, Maui, Oahu
152	Old Hawaiian	Oahu
153	Oman	Oman

RM Series GPS Receiver Supported Datums		
Number	Datum	Region
154	Ordnance Survey Great Britain 1936	England
155	Ordnance Survey Great Britain 1936	England, Isle of Man, Wales
156	Ordnance Survey Great Britain 1936	Mean For England, Isle of Man, Scotland, Shetland Island, Wales
157	Ordnance Survey Great Britain 1936	Scotland, Shetland Islands
158	Ordnance Survey Great Britain 1936	Wales
159	Pico de las Nieves	Canary Islands
160	Pitcairn Astro 1967	Pitcairn Island
161	Point 58	Mean for Burkina Faso and Niger
162	Pointe Noire 1948	Congo
163	Porto Santo 1936	Porto Santo, Madeira Islands
164	Provisional South American 1956	Bolivia
165	Provisional South American 1956	Chile (Northern Near 19 deg S)
166	Provisional South American 1956	Chile (Southern Near 43 deg S)
167	Provisional South American 1956	Colombia
168	Provisional South American 1956	Ecuador
169	Provisional South American 1956	Guyana
170	Provisional South American 1956	Mean for Bolivia Chile, Colombia, Ecuador, Guyana, Peru, Venezuela
171	Provisional South American 1956	Peru
172	Provisional South American 1956	Venezuela
173	Provisional South Chilean 1963	Chile (Near 53 deg S) (Hito XVIII)
174	Puerto Rico	Puerto Rico, Virgin Islands
175	Pulkovo 1942	Russia
176	Qatar National	Qatar
177	Qornoq	Greenland (South)
178	Reunion	Mascarene Island
179	Rome 1940	Italy (Sardinia)
180	S-42 (Pulkovo 1942)	Hungary
181	S-42 (Pulkovo 1942)	Poland
182	S-42 (Pulkovo 1942)	Czechoslovakia
183	S-42 (Pulkovo 1942)	Lativa
184	S-42 (Pulkovo 1942)	Kazakhstan
185	S-42 (Pulkovo 1942)	Albania
186	S-42 (Pulkovo 1942)	Romania
187	S-JTSK	Czechoslovakia (Prior 1 Jan1993)



RM Series GPS Receiver Supported Datums		
Number	Datum	Region
188	Santo (Dos) 1965	Espirito Santo Island
189	Sao Braz	Azores (Sao Miguel, Santa Maria Ids)
190	Sapper Hill 1943	East Falkland Island
191	Schwarzeck	Namibia
192	Selvagem Grande 1938	Salvage Islands
193	Sierra Leone 1960	Sierra Leone
194	South American 1969	Argentina
195	South American 1969	Bolivia
196	South American 1969	Brazil
197	South American 1969	Chile
198	South American 1969	Colombia
199	South American 1969	Ecuador
200	South American 1969	Ecuador (Baltra, Galapagos)
201	South American 1969	Guyana
202	South American 1969	Mean For Argentina, Bolivia, Brazil, Chile, Colombia, Ecuador, Guyana, Paraguay, Peru, Trinidad and Tobago, Venezuela
203	South American 1969	Paraguay
204	South American 1969	Peru
205	South American 1969	Trinidad and Tobago
206	South American 1969	Venezuela
207	South Asia	Singapore
208	Tananarive Observatory 1925	Madagascar
209	Timbalai 1948	Brunei, E Malaysia (Sabah Sarawak)
210	Tokyo	Japan
211	Tokyo	Mean for Japan, South Korea, Okinawa
212	Tokyo	Okinawa
213	Tokyo	South Korea
214	Tristan Astro 1968	Tristam Da Cunha
215	Viti Levu 1916	Fiji (Viti Levu Island)
216	Voirol 1960	Algeria
217	Wake Island Astro 1952	Wake Atoll
218	Wake-Eniwetok 1960	Marshall Islands
219	WGS 1972	Global Definition

RM Series GPS Receiver Supported Datums		
Number	Datum	Region
220	WGS 1984	Global Definition
221	Yacare	Uruguay
222	Zanderij	Suriname

Figure 44: Supported Datums

## Resources

### Support

For technical support, product documentation, application notes, regulatory guidelines and software updates, visit [www.linxtechnologies.com](http://www.linxtechnologies.com)

### RF Design Services

For customers who need help implementing Linx modules, Linx offers design services including board layout assistance, programming, certification advice and packaging design. For more complex RF solutions, Apex Wireless, a division of Linx Technologies, creates optimized designs with RF components and firmware selected for the customer's application. Call +1 800 736 6677 (+1 541 471 6256 if outside the United States) for more information.

### Antenna Factor Antennas

Linx's Antenna Factor division has the industry's broadest selection of antennas for a wide variety of applications. For customers with specialized needs, custom antennas and design services are available along with simulations of antenna performance to speed development. Learn more at [www.linxtechnologies.com](http://www.linxtechnologies.com).



## Notes



Linx Technologies  
159 Ort Lane  
Merlin, OR, US 97532

3090 Sterling Circle Suite 200  
Boulder, CO 80301

Phone: +1 541 471 6256  
Fax: +1 541 471 6251

[www.linxtechnologies.com](http://www.linxtechnologies.com)

#### Disclaimer

---

Linx Technologies is continually striving to improve the quality and function of its products. For this reason, we reserve the right to make changes to our products without notice. The information contained in this Data Guide is believed to be accurate as of the time of publication. Specifications are based on representative lot samples. Values may vary from lot-to-lot and are not guaranteed. "Typical" parameters can and do vary over lots and application. Linx Technologies makes no guarantee, warranty, or representation regarding the suitability of any product for use in any specific application. It is the customer's responsibility to verify the suitability of the part for the intended application. **NO LINX PRODUCT IS INTENDED FOR USE IN ANY APPLICATION WHERE THE SAFETY OF LIFE OR PROPERTY IS AT RISK.**

Linx Technologies **DISCLAIMS ALL WARRANTIES OF MERCHANTABILITY AND FITNESS FOR A PARTICULAR PURPOSE. IN NO EVENT SHALL LINX TECHNOLOGIES BE LIABLE FOR ANY OF CUSTOMER'S INCIDENTAL OR CONSEQUENTIAL DAMAGES ARISING IN ANY WAY FROM ANY DEFECTIVE OR NON-CONFORMING PRODUCTS OR FOR ANY OTHER BREACH OF CONTRACT BY LINX TECHNOLOGIES.** The limitations on Linx Technologies' liability are applicable to any and all claims or theories of recovery asserted by Customer, including, without limitation, breach of contract, breach of warranty, strict liability, or negligence. Customer assumes all liability (including, without limitation, liability for injury to person or property, economic loss, or business interruption) for all claims, including claims from third parties, arising from the use of the Products. The Customer will indemnify, defend, protect, and hold harmless Linx Technologies and its officers, employees, subsidiaries, affiliates, distributors, and representatives from and against all claims, damages, actions, suits, proceedings, demands, assessments, adjustments, costs, and expenses incurred by Linx Technologies as a result of or arising from any Products sold by Linx Technologies to Customer. Under no conditions will Linx Technologies be responsible for losses arising from the use or failure of the device in any application, other than the repair, replacement, or refund limited to the original product purchase price. Devices described in this publication may contain proprietary, patented, or copyrighted techniques, components, or materials. Under no circumstances shall any user be conveyed any license or right to the use or ownership of such items.