



LT Series
Basic Evaluation Kit
User's Guide

Wireless made simple[®]

Table of Contents

- 1 [Introduction](#)
- 2 [Ordering Information](#)
- 2 [LT Series Transceiver Evaluation Board](#)
- 2 [Board Objects](#)
- 3 [Theory of Operation](#)
- 4 [Development Using the Prototyping Area](#)
- 5 [Range Testing](#)
- 6 [About Antennas](#)
- 7 [Using the Boards as a Design Reference](#)
- 8 [Transceiver Evaluation Board](#)
- 10 [Technical Support](#)
- 11 [Resources](#)

LT Series Basic Evaluation Kit

User's Guide

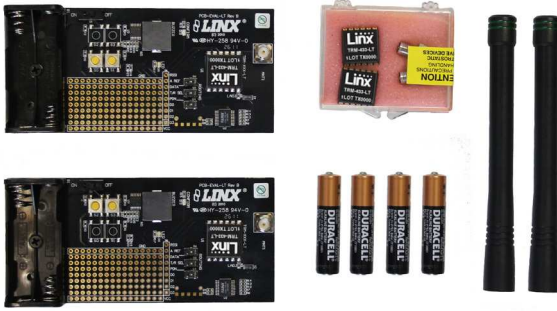

Figure 1: LT Series Basic Evaluation Kit

Introduction

LinX LT Series RF transceiver modules offer a simple, efficient and cost-effective method of adding wireless communication capabilities to any product. The Basic Evaluation Kit is intended to give a designer all the tools necessary to correctly and legally incorporate the LT Series modules into an end product. The evaluation boards themselves serve several important functions:

- **Rapid Module Evaluation:** The boards allow the performance of the LinX LT Series modules to be evaluated quickly in a user's environment.
- **Application Development:** An onboard prototyping area allows for the development of applications directly on the evaluation board. All signal lines are available on a header for easy access.
- **Range Testing:** Using the on-board transcoders to generate a duplex transmission, a pair of evaluation boards can be used to evaluate the range performance of the modules.
- **Design Benchmark:** The boards provide a known benchmark against which the performance of a custom design may be judged.

This kit includes 4 LT Series transceivers*, 2 MT Series transcoders*, 2 extra PCB-mount RP-SMA connectors, 2 evaluation boards, 2 CW Series antennas, 4 AAA batteries, and full documentation.

* One part is soldered to each board. Two extras are for use on your first prototype boards.

Ordering Information

Ordering Information

Part Number	Description
EVAL-***-LT	LT Series Basic Evaluation Kit

*** = 315, 418 (Standard), 433MHz

Figure 2: Ordering Information

LT Series Transceiver Evaluation Board

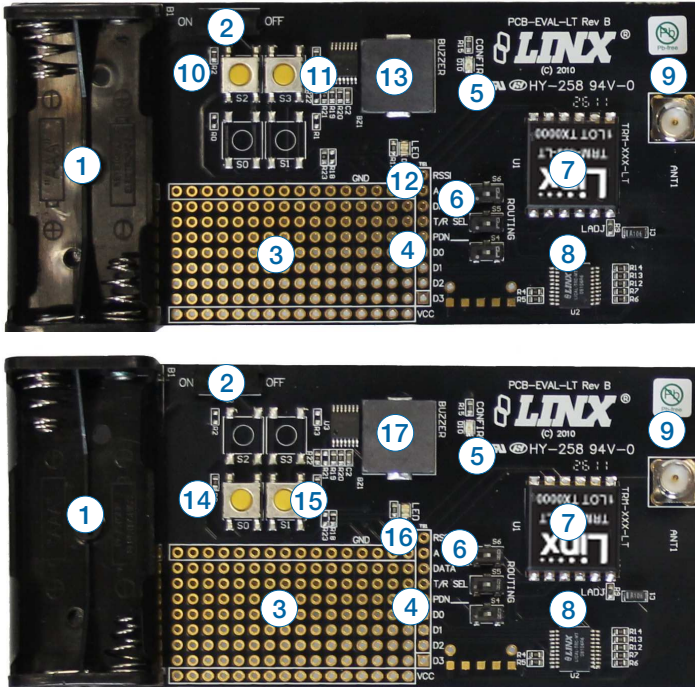

Figure 3: LT Series Transceiver Evaluation Board

Board Objects

1. Battery – 3VDC
2. Power Switch
3. Prototyping Area
4. Breakout Header
5. Confirmation LED
6. Routing Switches
7. LT Series Transceiver Module
8. MT Series Transcoder Chip
9. Reverse-Polarity SMA Antenna Connector
10. LED Button – D2
11. Buzzer Button – D3
12. LED – D0
13. Buzzer – D1
14. LED Button – D0
15. Buzzer Button – D1
16. LED – D2
17. Buzzer – D3

Theory of Operation

The two transceiver evaluation boards are identical, but they are populated slightly differently. The MT Series transcoder is both an encoder and a decoder, with the input or output nature of each line being determined by how the board is populated. One board will have buttons S0 and S1 populated, making those lines inputs. On the other board, those lines will be connected to the buzzer and LED, respectively. Conversely, the first board will have lines D2 and D3 connected to the buzzer and LED, while the second board has buttons S2 and S3 populated. This allows for bidirectional remote control. To use the kit, simply attach the antennas, turn on the power, and press one or both of the buttons on a board. When S0 or S2 is pressed, the buzzer will sound; when S1 or S3 is pressed, the LED will turn on.

Both boards have a confirmation LED. When one transcoder sends a command to the second transcoder, the second transcoder will send a confirmation back to the first transcoder indicating that the command was received and the action performed. When the first transcoder receives the confirmation, it will turn on the CONFIRM LED to indicate this. This feature offers the ability to range test without needing to be in visual or hearing range of both boards.

The MT Series Transcoder Data Guide goes into the many features of the transcoders in detail, but this is the only set-up required for operation of this kit.

Development Using the Prototyping Area

In addition to their evaluation functions, the boards may also be used for actual product development. They feature a prototyping area to facilitate the addition of application-specific circuitry. This area has a connection to VCC at the bottom and ground at the top which can be used to power the added circuitry.

Note: If the added circuitry requires a higher current, the on-board batteries must be removed and the board powered from an external source.

The holes are plated and set at 0.100" on center with a 0.040" diameter, making it easy to add most industry-standard SIP and DIP packages to the board.

All of the lines from the transceiver have been wired out to a row of plated holes on the right side of the prototyping area. Four of the data lines from the transcoder have also been wired out. This allows for easy access to connect external circuitry to the modules and the transcoder. Three lines from the transceiver (DATA, $\overline{\text{TR_SEL}}$, and PDN) have been routed to switches. The switches connect the lines to either the transcoder or the prototyping area. This allows the transceiver to be conveniently switched between the transcoder and application circuitry during testing.

Range Testing

Several complex mathematical models exist for determining path loss in many environments. These models vary as the transmitter and receiver are moved from indoor operation to outdoor operation. Although these models can provide an estimation of range performance in the field, the most reliable method is to simply perform range tests using the transmitter and receiver in the intended operational environment.

Basic range testing can be performed with the transceiver evaluation boards. To prepare the board for range testing, turn it on by switching the power switch to the ON position. Pressing S0 or S2 will activate the buzzer on the receiver board, while S1 or S3 activates the LED. The CONFIRM LED provides an indication that the signal has traveled round trip, so only one person is needed to conduct range testing.

As you near the maximum range of the link in your area, it is not uncommon for the signal to cut in and out as you move. This is normal and can result from other interfering sources or fluctuating signal levels due to multi-path effects. This results in cancellation of the transmitted signal as direct and reflected signals arrive at the receiver at differing times and phases. The areas in which this occurs are commonly called “nulls” and simply walking a little farther will usually restore the signal.

Since the evaluation boards are intended for use by design engineers, they are not FCC certified. The transmitter section has been attenuated to approximate legal limits by resistor R9 so that the range test results will approximate the results from a well-designed, certified product. For applications where Part 15 limits are not applicable, or output levels can be legally raised due to protocol duty cycle, R9 can be changed according to the Output Power vs. LADJ Resistance graph in the LT Series Transceiver Module Data Guide.

To achieve maximum range, keep objects such as your hand away from the antenna and ensure that the antenna on the transmitting board has a clear and unobstructed line-of-sight path to the receiving board. Range performance is determined by many interdependent factors. If the range you are able to achieve is significantly less than what is specified by Linx for the products you are testing, then there is likely a problem with either the board or the ambient RF environment in which the board is operating. First, check the battery, switch positions, and antenna connection.

Next, measure the transceiver's RSSI voltage with the other transceiver turned off to determine if ambient interference is present. If this fails to resolve the issue, please contact Linx technical support.

About Antennas

The choice of antennas is one of the most critical and often overlooked design considerations. The range, performance, and legality of an RF link are critically dependent upon the type of antenna employed. Linx offers a variety of antenna styles that you may wish to consider for your design. Included with your kit are HD Series (315MHz) or CW Series (418MHz and 433MHz) connectorized whip antennas that should be connected prior to using the kit. Despite the fact that the antenna is not centered on the board's ground plane, it exhibits a VSWR of <1.7 and suitably demonstrates the module's best practical performance.

Using the Boards as a Design Reference

The basic evaluation boards included in this kit are very simple, yet they illustrate some important techniques that you may wish to incorporate into your own board layout. You will observe that the LT mounting pads extend slightly past the edge of the part. This eases hand assembly and allows for better heat conduction under the part if rework is necessary. Next, observe the use of a full ground plane fill on the lower side of the board. This ground plane serves three important purposes:

First, since a quarter-wave antenna is employed, the ground plane is critical to serve as a counterpoise (you may wish to read Application Notes AN-00500 and AN-00501 for additional details on how a ground plane affects antenna function).

Second, a ground plane can help minimize the transfer of noise between stages of a product, as well as unintentional radiation of noise into free space.

Third, a ground plane allows for the implementation of a microstrip feed to the antenna. The term microstrip refers to a PCB trace running over a ground plane that is designed to serve as a 50-ohm transmission line between the module and the antenna. A microstrip is implemented on this evaluation board. If you are unfamiliar with microstrip calculations, you may wish to refer to the LT Series Transceiver Module Data Guide or the calculator available on our website, www.linxtechnologies.com.

Transceiver Evaluation Board

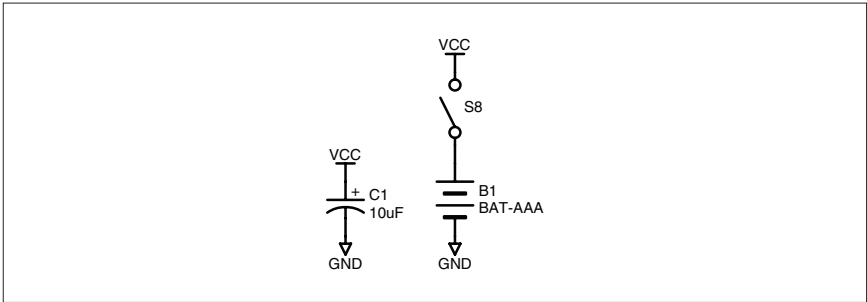

Figure 4: Power Supply Section

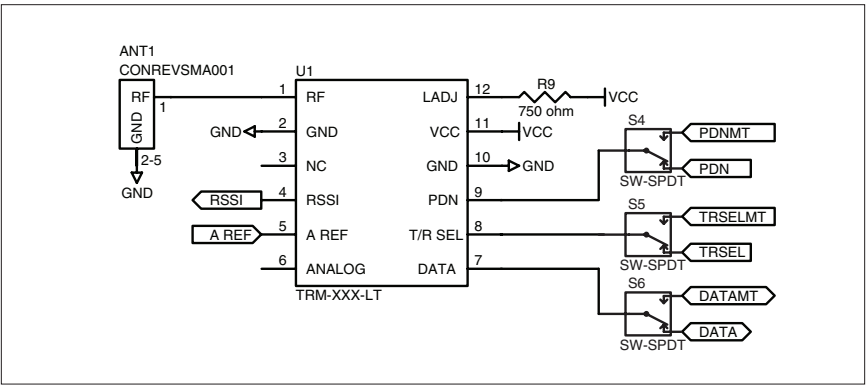

Figure 5: RF Module Section

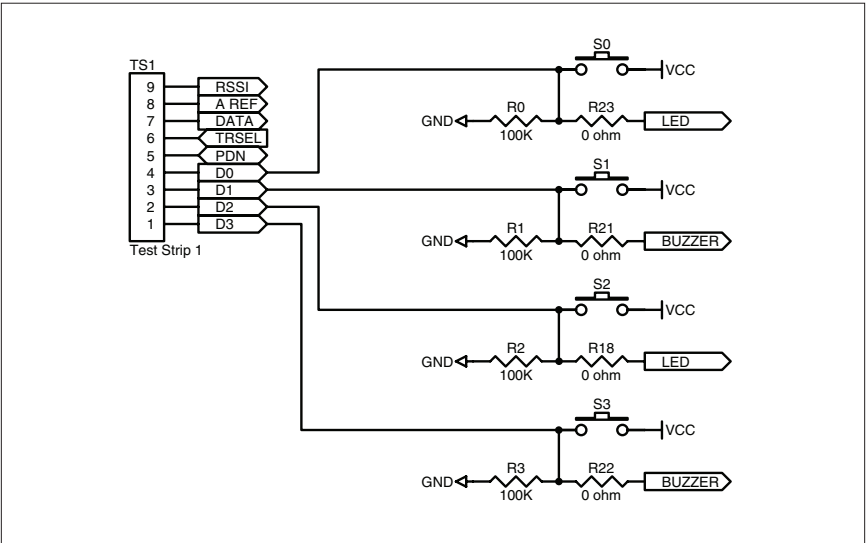

Figure 6: Header Section

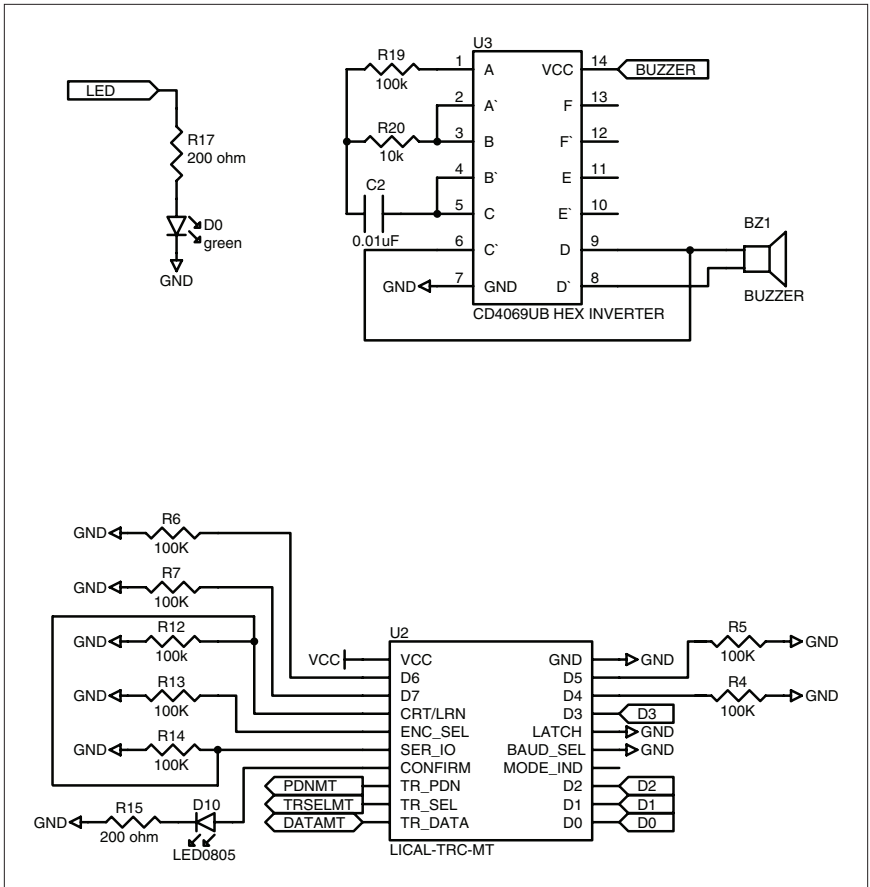

Figure 7: Duplex Range Test Section

Technical Support

For help with Linx products, call technical support at +1 800 736 6677 (+1 541 472 6256 if outside the United States) or send an email to info@linxtechnologies.com.

Legal Notice: All Linx kits are designed in keeping with high engineering standards; however, it is the responsibility of the user to ensure that the products are operated in a legal and appropriate manner. The purchaser understands that the legal operation may require additional permits, approvals, or certifications prior to use, depending on the country and operation.

Resources

Support

For technical support, product documentation, application notes, regulatory guidelines and software updates, visit www.linxtechnologies.com

RF Design Services

For customers who need help implementing Linx modules, Linx offers design services including board layout assistance, programming, certification advice and packaging design. For more complex RF solutions, Apex Wireless, a division of Linx Technologies, creates optimized designs with RF components and firmware selected for the customer's application. Call +1 800 736 6677 (+1 541 471 6256 if outside the United States) for more information.

Antenna Factor Antennas

Linx's Antenna Factor division has the industry's broadest selection of antennas for a wide variety of applications.

For customers with specialized needs, custom antennas and design services are available along with simulations of antenna performance to speed development. Learn more at www.linxtechnologies.com.

AntennaFactor
by **Linx**



Linx Technologies
159 Ort Lane
Merlin, OR, US 97532

3090 Sterling Circle, Suite 200
Boulder, CO 80301

Phone: +1 541 471 6256
Fax: +1 541 471 6251
www.linxtechnologies.com

Disclaimer

Linx Technologies is continually striving to improve the quality and function of its products. For this reason, we reserve the right to make changes to our products without notice. The information contained in this Data Guide is believed to be accurate as of the time of publication. Specifications are based on representative lot samples. Values may vary from lot-to-lot and are not guaranteed. "Typical" parameters can and do vary over lots and application. Linx Technologies makes no guarantee, warranty, or representation regarding the suitability of any product for use in any specific application. It is Customer's responsibility to verify the suitability of the part for the intended application. At Customer's request, Linx Technologies may provide advice and assistance in designing systems and remote control devices that employ Linx Technologies RF products, but responsibility for the ultimate design and use of any such systems and devices remains entirely with Customer and/or user of the RF products.

LINX TECHNOLOGIES DISCLAIMS ANY AND ALL WARRANTIES OF MERCHANTABILITY AND FITNESS FOR A PARTICULAR PURPOSE. IN NO EVENT SHALL LINX TECHNOLOGIES BE LIABLE FOR ANY CUSTOMER'S OR USER'S INCIDENTAL OR CONSEQUENTIAL DAMAGES ARISING OUT OF OR RELATED TO THE DESIGN OR USE OF A REMOTE CONTROL SYSTEM OR DEVICE EMPLOYING LINX TECHNOLOGIES RF PRODUCTS OR FOR ANY OTHER BREACH OF CONTRACT BY LINX TECHNOLOGIES. CUSTOMER AND/OR USER ASSUME ALL RISKS OF DEATH, BODILY INJURIES, OR PROPERTY DAMAGE ARISING OUT OF OR RELATED TO THE USE OF LINX TECHNOLOGIES RF PRODUCTS, INCLUDING WITH RESPECT TO ANY SERVICES PROVIDED BY LINX RELATED TO THE USE OF LINX TECHNOLOGIES RF PRODUCTS. LINX TECHNOLOGIES SHALL NOT BE LIABLE UNDER ANY CIRCUMSTANCES FOR A CUSTOMER'S, USER'S, OR OTHER PERSON'S DEATH, BODILY INJURY, OR PROPERTY DAMAGE ARISING OUT OF OR RELATED TO THE DESIGN OR USE OF A REMOTE CONTROL SYSTEM OR DEVICE EMPLOYING LINX TECHNOLOGIES RF PRODUCTS.

The limitations on Linx Technologies' liability are applicable to any and all claims or theories of recovery asserted by Customer, including, without limitation, breach of contract, breach of warranty, strict liability, or negligence. Customer assumes all liability (including, without limitation, liability for injury to person or property, economic loss, or business interruption) for all claims, including claims from third parties, arising from the use of the Products. Under no conditions will Linx Technologies be responsible for losses arising from the use or failure of the device in any application, other than the repair, replacement, or refund limited to the original product purchase price. Devices described in this publication may contain proprietary, patented, or copyrighted techniques, components, or materials.