



DS Series
Basic Evaluation Kit
User's Guide

Wireless made simple[®]



Warning: Linx radio frequency ("RF") products may be used to control machinery or devices remotely, including machinery or devices that can cause death, bodily injuries, and/or property damage if improperly or inadvertently triggered, particularly in industrial settings or other applications implicating life-safety concerns. No Linx Technologies product is intended for use in any application without redundancies where the safety of life or property is at risk.

The customers and users of devices and machinery controlled with RF products must understand and must use all appropriate safety procedures in connection with the devices, including without limitation, using appropriate safety procedures to prevent inadvertent triggering by the user of the device and using appropriate security codes to prevent triggering of the remote controlled machine or device by users of other remote controllers.

Do not use simple or common addressing schemes:

When designing remote control applications, it is very important to use unique addressing between devices. This eliminates opportunities for accidental triggering of unintentional devices within range. For example, if next door neighbors have matching addresses for their garage doors, each person would open both garage doors when transmitting from a single remote controller. Likewise, suppose a person shouts "John" in a room full of people. Each person named John will respond. However, if the person shouts "John Smith", only people with the first same and last name will respond. For this reason it is very important to set the address to a unique configuration.

Note: The DS Series has 10 address inputs which can be set to over a thousand combinations. It is extremely important to mix up the address logic, making the address more likely to be unique. Simple addressing schemes, such as the first 9 address pins set to the same logic and the 10th address pin being inverted is NOT recommended.

Table of Contents

- 1 [Introduction](#)
- 2 [Ordering Information](#)
- 2 [DS Series Encoder Evaluation Board](#)
- 3 [DS Series Decoder Evaluation Board](#)
- 4 [Theory of Operation](#)
 - 4 [Encoder Evaluation Board](#)
 - 4 [Decoder Evaluation Board](#)
- 4 [Using the Kit](#)
- 5 [Development Using the Prototyping Area](#)
- 6 [Range Testing](#)
- 7 [About Antennas](#)
- 7 [Using the Boards as a Design Reference](#)
- 8 [In Closing](#)
- 10 [DS Series Encoder Evaluation Board Schematic](#)
- 11 [DS Series Decoder Evaluation Board Schematic](#)



Figure 1: DS Series Basic Evaluation Kit

Introduction

Linx DS Series encoder / decoder, when paired with Linx LR Series RF modules offer a simple, efficient and cost-effective method of adding wireless remote control capabilities to any product. The Basic Evaluation Kit is intended to give a designer all the tools necessary to correctly and legally incorporate the DS Series encoder / decoder and the LR Series modules into an end product. The development boards themselves serve several important functions:

- **Rapid Evaluation:** The boards allow the performance of the Linx encoder / decoder ICs and the Linx LR Series modules to be evaluated quickly in a user's environment.
- **Application Development:** An on-board prototyping area allows for the development of applications directly on the development board. All signal lines are available on a header for easy access.
- **Range Testing:** Using the on-board encoders and decoders to generate a simplex transmission, a pair of development boards can be used to evaluate the range performance of the modules.
- **Design Benchmark:** The boards provide a known benchmark against which the performance of a custom design may be judged.

The purpose of this guide is to show the designer how to take full advantage of the basic development boards included with the kit.

The kit includes 4 DS Series encoders / decoders*, 2 LR Series transmitters*, 2 LR Series receivers*, 2 development boards, 2 CW Series antennas, 1 CR2032 battery, 2 AAA batteries and full documentation.

* Two DS Series encoders / decoders, 1 LR Series transmitter and 1 LR Series receiver are soldered to the board, the rest are for use on prototypes.

Ordering Information

Ordering Information	
Part Number	Description
EVAL-xxx-DS	DS Series Basic Evaluation Kit
LICAL-EDC-DS001	DS Series Encoder/Decoder

xxx = 315, 418 (Standard), 433MHz

Figure 2: Ordering Information

DS Series Encoder Evaluation Board

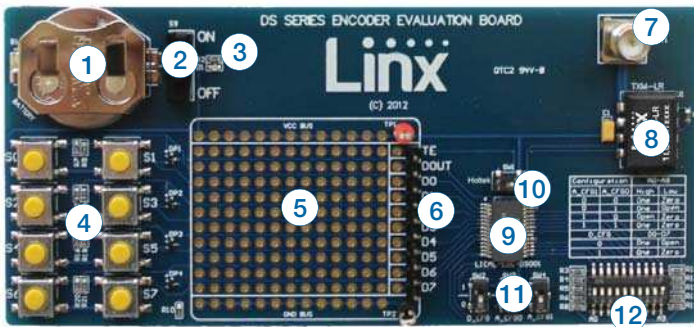

Figure 3: DS Series Encoder Evaluation Board

1. Battery – 3VDC (use a CR2032-style battery only)
2. Power Switch
3. Power On Indicator LED
4. Momentary Pushbuttons
5. Prototyping Area
6. Breakout Header
7. Reverse-Polarity SMA Antenna Connector
8. LR Series Transmitter Module
9. DS Series Encoder / Decoder
10. Protocol Select Switch
11. Holtek Protocol Configuration Switches
12. Address Configuration DIP Switch

DS Series Decoder Evaluation Board

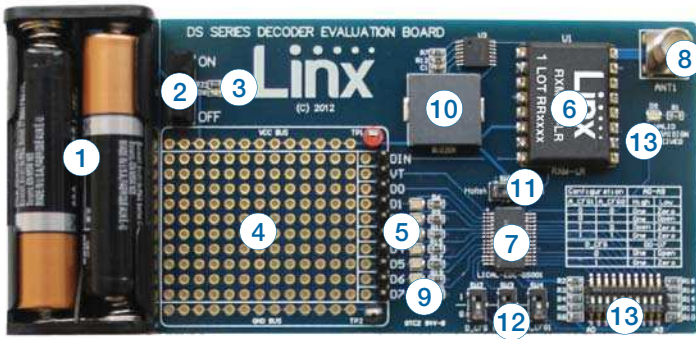

Figure 4: DS Series Decoder Evaluation Board

1. Battery – 3VDC (use 2 AAA style batteries)
2. Power Switch
3. Power On Indicator LED
4. Prototyping Area
5. Breakout Header
6. LR Series Receiver Module
7. DS Series Encoder / Decoder
8. Reverse-Polarity SMA Antenna Connector
9. LEDs – D1–D7
10. Buzzer – D0
11. Protocol Select Switch
12. Holtek Configuration Switches
13. Address Configuration DIP Switch
14. Valid Transmission Received LED

Theory of Operation

Encoder Evaluation Board

The transmitter board is powered by an on-board 3V CR2032 lithium battery. It has eight SPST pushbutton switches, the state of which is encoded into a data stream using the DS Series as an encoder. If a switch is closed, the transmitter is enabled while the encoder captures the pushbutton states for encoding and transmission. Buttons S0 (D0) and S1 (D1) are used to activate the LED and buzzer on the receiver board. All of the data lines are wired out to the header to the right of the prototyping area and can be accessed for use with other switches, contacts or microcontrollers.

Decoder Evaluation Board

The receiver board is powered by two AAA batteries. The data recovered by the LR Series receiver is decoded using the DS Series as a decoder, and the data line outputs are updated to match the state of the data line inputs (or pushbuttons) on the transmitter board. To demonstrate this, one data line is used to activate a buzzer while the other seven are used to drive LEDs. This board also has a prototyping area with all of the receiver and decoder lines brought out to a header.

Using the Kit

Using the kit is straightforward. Simply attach the antennas, turn on the power, and press one or both of the buttons on the transmitter board. When S0 is pressed, the buzzer will sound; when S1–S7 are pressed, the LEDs will turn on. When any button (S0–S7) is pressed on the transmitter board, the corresponding decoder output (D0–D7) is active high (V_{CC}) on the prototyping header.

Note: All switches (address, protocol select and Holtek configuration) must match on both the encoder and decoder boards.

Selecting the Protocol

The DS Series encoder / decoder offers two over-the-air protocols. The Holtek selection is used when communicating with other Holtek devices. The serial selection offers a much more reliable protocol to allow better range and response time. See the DS Series Data Guide for more details.

Setting the Address

The address is made of ten inputs from the DIP switch, resulting in 1,022 ($2^{10} - 2$) possible combinations. It's important to remember that all switches placed on or off are not valid addresses and will be ignored. At least one input must be different from the rest. Both the encoder and decoder board must have matching addresses.



Warning: When designing remote control applications, it is very important to use unique addressing between devices. This eliminates opportunities for accidental triggering of unintentional devices within range. For example, if next door neighbors have matching addresses for their garage doors, each person would open both garage doors when transmitting from a single remote controller. Likewise, suppose a person shouts “John” in a room full of people. Each person named John will respond. However, if the person shouts “John Smith”, only people with the first same and last name will respond. For this reason it is very important to set the address to a unique configuration.

Note: The DS Series has 10 address inputs which can be set to over a thousand combinations. It is extremely important to mix up the address logic, making the address more likely to be unique. Simple addressing schemes, such as the first 9 address pins set to the same logic and the 10th address pin being inverted is NOT recommended.

Configuring the Holtek Protocol

The Holtek configuration switches are only necessary when using the Holtek protocol; they can be ignored when using the Serial protocol. These switches determine the Data and Address bit types for the Holtek protocol. It's important that the encoder and decoder boards have matching configurations. See the DS Series Data Guide for further details.

Development Using the Prototyping Area

In addition to their evaluation functions, the boards may also be used for actual product development. They feature a prototyping area to facilitate the addition of application-specific circuitry.

Note: The CR2032-style battery on the transmitter board has very low current capacity with, only about 3mA available for external circuitry. If added circuitry requires a higher current, the battery must be removed and the board powered from an external source.

This area has a connection to V_{CC} at the top and ground at the bottom that can be used to power the added circuitry. The holes are plated and set at 0.100" on center with a 0.040" diameter, making it easy to add most industry-standard SIP and DIP packages to the board.

On the encoder board, the Transmit Enable (TE), Data Output (DOUT) and data lines (D0–D7) from the encoder have been wired out to a row of plated holes on the right side of the prototyping area. On the receiver board, the Data In (DIN), the Valid Transmission (VT) and the data lines (D0–D7) from the decoder have been wired out. This allows easy access to connect external circuitry to the encoder and decoder. Data line D0 is connected to the buzzer, D1–D7 are connected to LEDs and VT is also connected to an LED.

Range Testing

Several complex mathematical models exist for determining path loss in many environments. These models vary as the transmitter and receiver are moved from indoor operation to outdoor operation. Although these models can provide an estimation of range performance in the field, the most reliable method is to simply perform range tests using the transmitter and receiver in the intended operational environment.

Simple range testing can be performed with the transmitter and receiver evaluation boards. To prepare the board for range testing, simply turn it on by switching the power switch to the ON position. Pressing S0 on the transmitter activates the buzzer on the receiver board. For continuous transmit, connect D0 to V_{CC} . This allows the designer to turn on the transmitter and walk with the receiver.

As you near the maximum range of the link in your area, it is not uncommon for the signal to cut in and out as you move. This is normal and can result from other interfering sources or fluctuating signal levels due to multipath effects. This results in cancellation of the transmitted signal as direct and reflected signals arrive at the receiver at differing times and phases. The areas in which this occurs are commonly called “nulls” and simply walking a little farther usually restores the signal.

Since the evaluation boards are intended for use by design engineers, they are not FCC certified. The transmitter has been set to approximate legal limits by resistor R9 so that the range test results approximate the results from a well-designed, certified product. For applications where Part 15 limits are not applicable or output levels can be legally raised due to

protocol duty cycle, R1 can be changed according to the graph in Figure 7 (Output Power vs. LADJ Resistance) of the LR Series Transmitter Data Guide.

To achieve maximum range, keep objects such as your hand away from the antenna and ensure that the antenna on the transmitter has a clear and unobstructed line-of-sight path to the receiver board. Range performance is determined by many interdependent factors. If the range you are able to achieve is significantly less than specified by Linx for the products you are testing, then there is likely a problem with either the board or the ambient RF environment in which the board is operating. First, check the battery, switch positions, and antenna connection. Next, measure the receiver's RSSI voltage with the transmitter turned off to determine if ambient interference is present. If this fails to resolve the issue, please contact Linx technical support.

About Antennas

The choice of antennas is one of the most critical and often overlooked design considerations. The range, performance, and legality of an RF link are critically dependent upon the type of antenna employed. Linx offers a variety of antenna styles that you may wish to consider for your design. Included with your kit is a Linx CW Series connectorized whip antenna that should be connected prior to using the kit. Despite the fact that the antenna is not centered on the board's ground plane, it exhibits a VSWR of <1.7 and suitably demonstrates the module's best practical performance.

Using the Boards as a Design Reference

The basic evaluation boards included in this kit are very simple, yet they illustrate some important techniques that you may wish to incorporate into your own board layout. You will observe that the PCB mounting pads extend slightly past the edge of the part. This eases hand assembly and allows for better heat conduction under the part if rework is necessary. Next, observe the use of a full ground plane fill on the lower side of the board. This ground plane serves three important purposes:

First, since a quarter-wave antenna is employed, the ground plane is critical to serve as a counterpoise (you may wish to read Application Note AN-00500 Antennas: Design, Application, and Performance for additional details on how a ground plane affects antenna function).

Second, a ground plane suppresses the transfer of noise between stages of a product, as well as unintentional radiation of noise into free space.

Third, a ground plane allows for the implementation of a microstrip feed to the antenna. The term microstrip refers to a PCB trace running over a ground plane that is designed to serve as a 50-ohm transmission line between the module and the antenna. A microstrip is implemented on this evaluation board. If you are unfamiliar with microstrip calculations, you may wish to refer to the DS Series Data Guide or the calculator available on our website.

In Closing

Here at Linx, “Wireless Made Simple” is more than just our motto, it is our commitment. A commitment to the highest caliber of product, service and support. That is why, should you have questions or encounter any difficulties using the evaluation kit, you’ll be glad to know many resources are available to assist you. Visit our website at www.linxtechnologies.com or call +1 541 471 6256 between 7AM and 5PM Pacific Time to speak with an application engineer.

Legal Notice: All Linx kits and modules are designed in keeping with high engineering standards; however, it is the responsibility of the user to ensure that the products are operated in a legal and appropriate manner. The purchaser understands that legal operation may require additional permits, approvals, or other certifications prior to use, depending on the country of operation.

(This page is intentionally blank.)

DS Series Encoder Evaluation Board Schematic

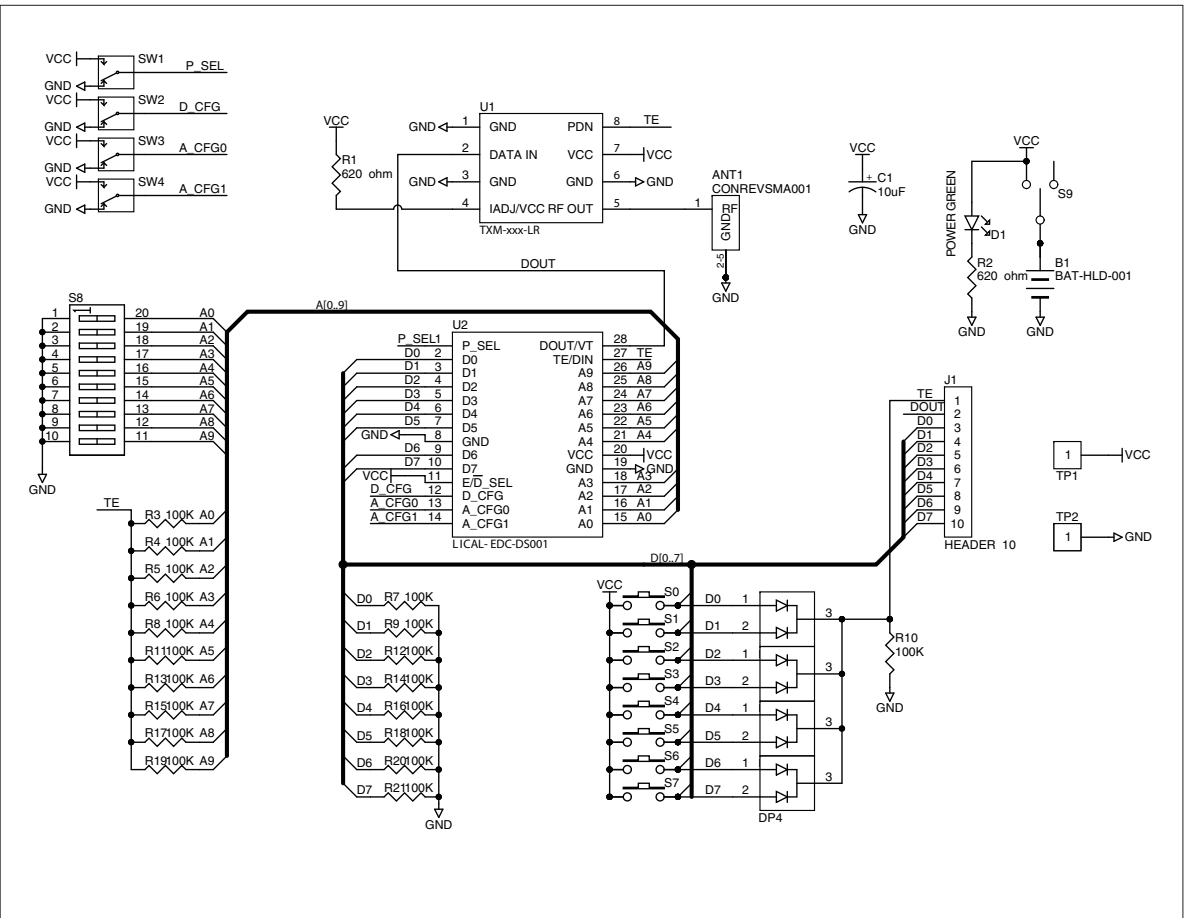

Figure 5: DS Series Encoder Board Schematic

DS Series Decoder Evaluation Board Schematic

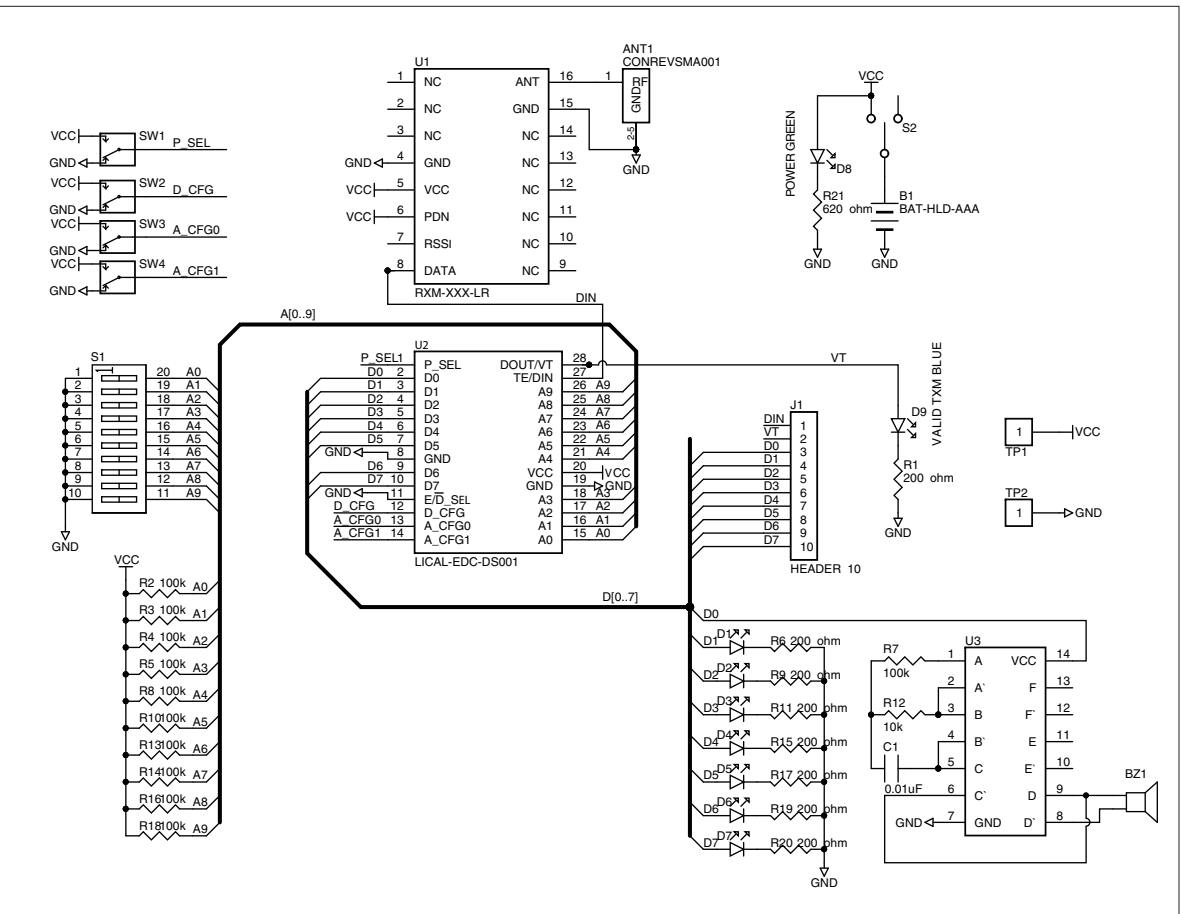

Figure 6: DS Series Decoder Board Schematic



Linx Technologies
159 Ort Lane
Merlin, OR, US 97532

3090 Sterling Circle, Suite 200
Boulder, CO 80301

Phone: +1 541 471 6256
Fax: +1 541 471 6251
www.linxtechnologies.com

Disclaimer

Linx Technologies is continually striving to improve the quality and function of its products. For this reason, we reserve the right to make changes to our products without notice. The information contained in this Data Guide is believed to be accurate as of the time of publication. Specifications are based on representative lot samples. Values may vary from lot-to-lot and are not guaranteed. "Typical" parameters can and do vary over lots and application. Linx Technologies makes no guarantee, warranty, or representation regarding the suitability of any product for use in any specific application. It is Customer's responsibility to verify the suitability of the part for the intended application. At Customer's request, Linx Technologies may provide advice and assistance in designing systems and remote control devices that employ Linx Technologies RF products, but responsibility for the ultimate design and use of any such systems and devices remains entirely with Customer and/or user of the RF products.

LINX TECHNOLOGIES DISCLAIMS ANY AND ALL WARRANTIES OF MERCHANTABILITY AND FITNESS FOR A PARTICULAR PURPOSE. IN NO EVENT SHALL LINX TECHNOLOGIES BE LIABLE FOR ANY CUSTOMER'S OR USER'S INCIDENTAL OR CONSEQUENTIAL DAMAGES ARISING OUT OF OR RELATED TO THE DESIGN OR USE OF A REMOTE CONTROL SYSTEM OR DEVICE EMPLOYING LINX TECHNOLOGIES RF PRODUCTS OR FOR ANY OTHER BREACH OF CONTRACT BY LINX TECHNOLOGIES. CUSTOMER AND/OR USER ASSUME ALL RISKS OF DEATH, BODILY INJURIES, OR PROPERTY DAMAGE ARISING OUT OF OR RELATED TO THE USE OF LINX TECHNOLOGIES RF PRODUCTS, INCLUDING WITH RESPECT TO ANY SERVICES PROVIDED BY LINX RELATED TO THE USE OF LINX TECHNOLOGIES RF PRODUCTS. LINX TECHNOLOGIES SHALL NOT BE LIABLE UNDER ANY CIRCUMSTANCES FOR A CUSTOMER'S, USER'S, OR OTHER PERSON'S DEATH, BODILY INJURY, OR PROPERTY DAMAGE ARISING OUT OF OR RELATED TO THE DESIGN OR USE OF A REMOTE CONTROL SYSTEM OR DEVICE EMPLOYING LINX TECHNOLOGIES RF PRODUCTS.

The limitations on Linx Technologies' liability are applicable to any and all claims or theories of recovery asserted by Customer, including, without limitation, breach of contract, breach of warranty, strict liability, or negligence. Customer assumes all liability (including, without limitation, liability for injury to person or property, economic loss, or business interruption) for all claims, including claims from third parties, arising from the use of the Products. Under no conditions will Linx Technologies be responsible for losses arising from the use or failure of the device in any application, other than the repair, replacement, or refund limited to the original product purchase price. Devices described in this publication may contain proprietary, patented, or copyrighted techniques, components, or materials.