



**MT Series
Transcoder Module
Data Guide**

Wireless made simple[®]



Warning: Linx radio frequency ("RF") products may be used to control machinery or devices remotely, including machinery or devices that can cause death, bodily injuries, and/or property damage if improperly or inadvertently triggered, particularly in industrial settings or other applications implicating life-safety concerns. No Linx Technologies product is intended for use in any application without redundancies where the safety of life or property is at risk.

The customers and users of devices and machinery controlled with RF products must understand and must use all appropriate safety procedures in connection with the devices, including without limitation, using appropriate safety procedures to prevent inadvertent triggering by the user of the device and using appropriate security codes to prevent triggering of the remote controlled machine or device by users of other remote controllers.

Do not use this or any Linx product to trigger an action directly from the data line or RSSI lines without a protocol or encoder/decoder to validate the data. Without validation, any signal from another unrelated transmitter in the environment received by the module could inadvertently trigger the action. This module does not have data validation built in.

All RF products are susceptible to RF interference that can prevent communication. RF products without frequency agility or hopping implemented are more subject to interference. This module does not have frequency agility built in, but the developer can implement frequency agility with a microcontroller and the example code in Linx Reference Guide RG-00101.

Do not use any Linx product over the limits in this data guide. Excessive voltage or extended operation at the maximum voltage could cause product failure. Exceeding the reflow temperature profile could cause product failure which is not immediately evident.

Do not make any physical or electrical modifications to any Linx product. This will void the warranty and regulatory and UL certifications and may cause product failure which is not immediately evident.

Table of Contents

1	Description
1	Features
2	Applications
2	Ordering Information
2	Absolute Maximum Ratings
3	Electrical Specifications
4	Recommende Pad Layout
4	Production Considerations
5	Pin Assignments
5	Pin Descriptions
8	Overview
9	Transceiver Power Control
10	Operation with the MS Series
11	Transcoder Operation
14	Create Mode
14	Learn Mode
15	Transmit Mode
16	Receive Mode
16	TX ID
17	LATCH Mode
17	Targeted Device Addressing
18	Custom Data Transmission
18	Mode Entry Timings
20	Serial Output
21	Serial Mode
23	Serial Interface Command Set Definitions
24	Serial Interface Connections
29	Transcoder MODE_IND Definitions

- 30 **Legal Considerations**
- 34 **Typical Applications**
- 36 **Design Steps to Using the MT Series**
- 39 **Resources**

MT Series Transcoder Module

Data Guide



Description

MT Series transcoders are designed for bidirectional remote control applications. Eight status lines can be set up in any combination of inputs and outputs for the transfer of button or contact states. An automatic confirmation indicates that the transmission was successfully received. The large, twenty-four bit address size makes transmissions highly unique, minimizing the possibility of conflict between multiple devices. The MT also outputs the ID of the originating transcoder for logging or identification. Recognition of the individual outputs can be easily defined for each device by the manufacturer or

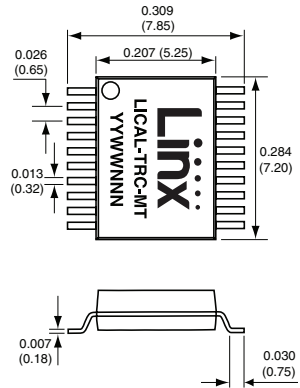

Figure 1: Package Dimensions

end user. This allows the creation of user groups and relationships. A Serial Interface Engine (SIE) is provided, which allows configuration and editing of the device and control of the transcoder by an external microprocessor or PC. Housed in a tiny 20-pin SSOP package, MT Series parts feature low supply voltage, current consumption and selectable baud rates.

Features

- Bidirectional control
- Automatic confirmation
- Secure 2^{24} possible addresses
- 8 status lines
- Serial Interface Engine (SIE)
- Latched and/or momentary outputs
- Definable recognition authority
- Transmitter ID output
- Custom data transfer
- Device targeting
- Wide 2.0 to 5.5V operating voltage
- Low supply current ($370\mu\text{A}$ @ 3V)
- True serial encoding
- Selectable baud rates
- No programming required

Applications

- Keyless entry
- Door and gate openers
- Security systems
- Remote device control
- Car alarms / starters
- Home / industrial automation
- Remote status monitoring
- Paging

Ordering Information

Ordering Information	
Part Number	Description
LICAL-TRC-MT	MT Transcoder
MDEV-LICAL-MT	MT Master Development System

MT transcoders are shipped in reels of 1,600

Figure 2: Ordering Information

Absolute Maximum Ratings

Absolute Maximum Ratings				
Supply Voltage V_{CC}	-0.3	to	+6.5	VDC
Any Input or Output Pin	-0.3	to	$V_{CC} + 0.3$	VDC
Max. Current Sourced by Output Pins		25		mA
Max. Current Sunk by Input Pins		25		mA
Max. Current Into V_{CC}		250		mA
Max. Current Out Of GND		300		mA
Operating Temperature	-40	to	+85	°C
Storage Temperature	-65	to	+150	°C

Exceeding any of the limits of this section may lead to permanent damage to the device. Furthermore, extended operation at these maximum ratings may reduce the life of this device.

Figure 3: Absolute Maximum Ratings

Electrical Specifications

MT Series Transceiver Specifications						
Parameter	Symbol	Min.	Typ.	Max.	Units	Notes
Power Supply						
Operating Voltage	V_{CC}	2.0		5.5	VDC	
Supply Current	I_{CC}					
At 2.0V V_{CC}			340	450	μA	1
At 3.0V V_{CC}			500	700	μA	1
At 5.0V V_{CC}			800	1,200	μA	1
Power Down Current	I_{PDN}					
At 2.0V V_{CC}			0.15	1.2	μA	
At 3.0V V_{CC}			0.20	1.5	μA	
At 5.0V V_{CC}			0.35	1.8	μA	
Transcoder Section						
Input Low	V_{IL}	0.0		$0.2 \times V_{CC}$	V	2
Input High	V_{IH}	$0.8 \times V_{CC}$		V_{CC}	V	3
Output Low	V_{OL}			0.6	V	
Output High	V_{OH}	$V_{CC} - 0.7$			V	
Input Sink Current				25	mA	
Output Drive Current				25	mA	
Environmental						
Operating Temperature Range		-40		+85	$^{\circ}C$	

1. Current consumption with no active loads.
2. For 3V supply, $(0.2 \times 3.0) = 0.6V$ max.
3. For 3V supply, $(0.8 \times 3.0) = 2.4V$ min.

Figure 4: Electrical Specifications



Warning: This product incorporates numerous static-sensitive components. Always wear an ESD wrist strap and observe proper ESD handling procedures when working with this device. Failure to observe this precaution may result in module damage or failure.

Recommended Pad Layout

The MT Series transcoders are implemented in an industry standard 20-pin Shrink Small Outline Package (20-SSOP). The recommended layout dimensions are shown in Figure 5.

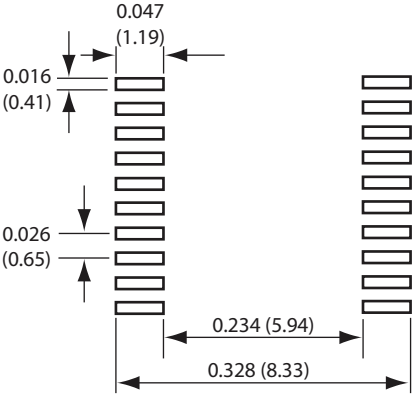

Figure 5: PCB Layout Dimensions

Production Considerations

These surface-mount components are designed to comply with standard reflow production methods. The recommended reflow profile is shown below and should not be exceeded, as permanent damage to the part may result.

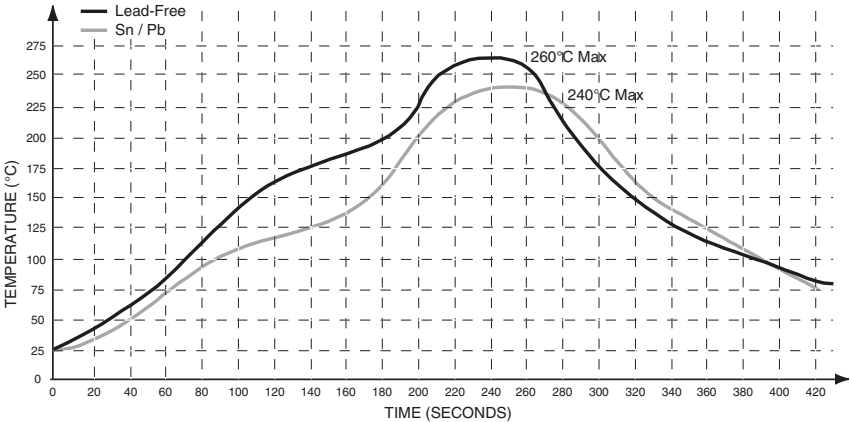

Figure 6: MT Series Reflow Profile

Pin Assignments

1	VCC	LICAL-TRC-MT	GND	20
2	D6		D5	19
3	D7		D4	18
4	CRT/LRN		D3	17
5	ENC_SEL		LATCH	16
6	SER_IO		SEL_BAUD	15
7	CONFIRM		MODE_IND	14
8	TR_PDN		D2	13
9	TR_SEL		D1	12
10	TR_DATA		D0	11

Figure 7: MT Series Transcoder Pin Assignments

Pin Descriptions

Pin Descriptions			
Pin Number	Name	I/O	Description
1	V _{CC}		Positive Power Supply
2, 3, 11–13, 17–19	D0–D7	I/O	Status Control Lines
4	CRT/LRN	I	Create / Learn Mode Activation Line
5	ECN_SEL	I	Encoder Only Select Line
6	SER_IO	I/O	Serial Interface Line
7	CONFIRM	O	Transmission Confirmation Line
8	TR_PDN	O	Transceiver Power Control Line
9	TR_SEL	O	Transceiver Mode Control Line
10	TR_DATA	I/O	Transceiver Data Line
14	MODE_IND	O	Mode Indicator Output
15	SEL_BAUD	I	Baud Rate Selection Line
16	LATCH	I	Set Latched Outputs
20	GND		Ground

None of the input lines have internal pull-up or pull-down resistors. The input lines must always be in a known state (either GND or V_{CC}) at all times or the operation may not be predictable. The designer must ensure that the input lines are never floating, either by using external resistors, by tying the lines directly to GND or V_{CC}, or by use of other circuits to control the line state.

Figure 8: Pin Descriptions

D0–D7

The transcoder has eight status lines, D0 through D7. These lines can be set as either inputs to record the state of switches or as outputs which will reproduce switch states upon reception of a valid transmission.

CRT/LRN

When this line goes high, the transcoder will enter Learn Mode. If it is held high for ten seconds, the transcoder will clear its memory. If it goes high while the ENC_SEL line is high, the transcoder will enter Create Mode. If it goes high while the SER_IO line is high, the transcoder will enter Serial Mode.

ENC_SEL

If this line is tied high, it will operate as an encoder only. If it is tied low, the transcoder will default to a decoder until it is set as a transcoder in Create Mode.

SER_IO

This line is used for the Serial Interface Engine, which allows the transcoder to be programmed by an external device. The transcoder will also use this line to output the ID of the originating transcoder, status line states, and custom data.

Confirm

This line will go high when the transcoder receives a confirmation that its transmission was received correctly.

TR_PDN

This line can be used to automatically control power to an external transceiver. When waiting for data the transcoder will toggle power to a transceiver at a 10% on to 90% off ratio. The times are determined by the selected baud rate.

TR_SEL

This line will toggle an external transceiver between transmit mode (high) and receive mode (low).

TR_DATA

This line will send data to and receive data from an external transceiver.

MODE_IND

This line will switch when a valid transmission is received, when Learn Mode or Create Mode is entered, and when the memory is cleared. This allows for the connection of a LED to indicate to the user that these events have taken place.

SEL_BAUD

This line is used to select the baud rate of the serial data stream. If the line is high, the baud rate will be 28,800bps, if it is low, the baud rate will be 9,600bps. The baud rate must be set before power up. The transcoder will not recognize any change in the baud rate setting after it is on.

LATCH

If this line is low, then the data outputs will be momentary (active for as long as a valid signal is received). If this line is high, the outputs will be latched (when a signal is received to make a particular data line high, it will remain high until another transmission is received instructing it to go low) by default, but individual status lines can be set as latched or momentary through the SIE.

Overview

Many products and applications call for the transfer of button presses or switch closures across a wireless link. Traditionally, a remote control link has operated in only one direction, from a transmitter to a receiver. The cost associated with transceivers has been too high to practically implement in low-cost products. With the increasing availability of low-cost transceiver solutions, bidirectional links are now practical and open a new world of opportunity.

In a wireless environment, maintaining the reliability and uniqueness of a transmitted signal is generally of great importance. In a unidirectional system, IC devices called encoders and decoders are often utilized to simplify this process. The encoder side turns the status of a number of input lines into an encoded serial bit-stream output intended for transmission via an RF or infrared link. Once received, the decoder decodes, error checks and analyzes the transmission. If the transmission is authenticated, the decoder's output lines are set to replicate the status of the encoder's input lines.

To accommodate bidirectional links, a new type of device has been developed. Called a transcoder, this device combines a remote control encoder and decoder into a single device, and is capable of sending commands as well as receiving them. It is also able to receive an automatic confirmation from the remote side indicating that its command was received and the appropriate action was taken. For example, verifying that an automobile's doors are all closed and have locked, or a remote valve has actually closed.

The Linx MT Series is a revolutionary transcoder product designed for wireless remote control applications. The same device can be used as an encoder, decoder, or transcoder and is ideal for both uni and bidirectional applications and even mixtures of the two. The MT Series is easily implemented, making it ideal for even the most basic applications, but its rich feature set also allows it to meet the needs of far more complex applications. These features include the ability to identify the originating transmitter, establish user permissions, select output latch modes on a "per pin" basis, and a powerful serial interface that allows control and information exchange with external microcontrollers or a PC.

Consider a brief example of how just one of the MT's innovative features could be used to transform a relatively simple application, the common garage door opener. In competitive devices, encoded transmissions

are generally either recognized or denied based on the address. If the addresses match, the state of all data lines will be recognized and output. The MT Series allows a user or manufacturer to establish a user identity and profile that determines which inputs will be acknowledged. Let's apply this capability practically to our example: a three door garage houses Dad's Corvette, Mom's Mercedes, and Son's Yugo. With most competitive products, any user's keyfob could open any garage door as long as the addresses match. In a Linx MT-based system, each individual keyfob could easily be configured to open only certain doors (guess which one Son gets to open!)

As you review this data guide keep in mind that it seeks to cover the full scope of the MT's capabilities. The implementation for a simple one button remote will be different than a powerful targeted control, command, or status network. While it is unlikely that all of the features of this part will be utilized at any one time, their availability provides great design flexibility and opens up many new opportunities for product innovation.

Transceiver Power Control

The transcoder has the option to control power to an external transceiver through the TR_PD_N line. This line can be connected to a power down or supply line of a Linx transceiver or a similar input on another transceiver. This allows the transcoder to power down the transceiver when it is not required, thereby reducing current consumption and prolonging battery life.

The transcoder pulls the TR_SEL line low to place the transceiver into receive mode and looks for valid data for 16mS or 32mS, depending on the baud rate. If data is present on the TR_DATA line, then the transcoder enters Receive Mode. If no data is present, then the transcoder pulls the TR_PD_N line low to power down the transceiver and goes to sleep for 150mS or 295mS. The "off" time is approximately nine times the "on" time, resulting in a 10% duty cycle, greatly reducing the transceiver's current consumption. However, there may be a lag time from when the transmitting transcoder activates to when the receiving transcoder responds. The transcoder enters Receive Mode when it sees a valid packet, so there would only be a lag for the first packet.

This cycle continues until data is received placing the transcoder into Receive Mode, until a status input line is taken high placing it into Transmit Mode, or the CRT/LRN line is taken high placing it into Serial, Learn, or Create Modes. If a faster response time is desired, then the TR_PD_N line can be left disconnected.

Operation with the MS Series

The MT Series transcoders are fully compatible with the MS Series encoders and decoders. Tying the ENC_SEL line high makes the transcoder operate just like an MS Series encoder. Tying this line low enables it to become an MS decoder or a transcoder, depending on how it is set-up. This is described in detail in the Transcoder Operation section.

There are two important issues of note when using the transcoders with the MS Series. First, only two of the MS baud rates are supported by the MT; 9,600bps and 28,800bps. Second, the MS Series will not respond to the advanced features of the MT, like the custom data and Targeted Device Addressing. The main advantage offered by the MT over the MS is the serial interface. This allows a number of advanced options to be realized. Some other advantages are:

- More users (60 vs. 40)
- Automatic confirmation
- The lower duty cycles (25% vs. 50%) of the MT Series allows for greater range in countries like the United States that average transmitter output power over time
- The serial output on every packet instead of just once per receive session
- Allows existing receive stations using the MS Series decoder to be upgraded to take advantage of the advanced features without having to upgrade existing transmitter stations based on the MS Series encoder
- Mixed MS / MT-based systems that allow cost savings for units that only require unidirectional operation while other units require bidirectional operation

Transcoder Operation

When the transcoder powers on for the first time, it is in a default set-up. When in this mode, the transcoder looks at the state of the ENC_SEL line on powerup. If the line is high, then the transcoder enters Default Encoder Mode and acts like an encoder only. It pulls the TR_SEL line high to set the transceiver into transmit mode and makes all of its status lines inputs. It will use a default address that is set at the factory.

If the ENC_SEL line is low, then the transcoder enters Default Decoder Mode and acts like a decoder only. It pulls the TR_SEL line low to set the transceiver into receive mode and makes all of its status lines outputs. At this point, the User Access is open, so the transcoder accepts all valid transmissions, regardless of address. This allows the designer to set up an external database for learned users and control permissions. The designer is free to set up a system of their choosing. External parts can be used with the transcoder to give the end product more memory to increase the number of users and more processing speed have a faster response time when scanning through the user list. In this mode, the transcoders become a data pipe around which a designer can create a larger, more complicated system than can be implemented with the transcoders alone.

The User Access can be locked simply by learning a user. From this point on, it requires that the transmission have a valid, learned address before it will respond. Only a Restore Default command sent on the serial interface will place the transcoder back into Default Decoder Mode. This command removes all existing settings and restores the transcoder to the factory default condition.

Once an address has been created, the transcoder enters a Defined set-up. The state of the ENC_SEL on power-up also determines the mode of operation in this set-up. If the ENC_SEL line is high, the transcoder enters Defined Encoder Mode. The process of creating an address also defines which status lines are inputs and which are outputs. In this mode, the transcoder acts as an encoder only using just the defined inputs and the address that was created.

If the ENC_SEL line is low, the transcoder enters Transcoder Mode and uses both the inputs and outputs as well as the defined address. In this mode, it can send commands as well as receive commands. As above, the User Access is open until a user is learned into memory.

Table 2 shows the different modes and how they are entered.

If the transcoder has been previously set up, through creating an address and learning users, then the saved settings are applied and the transcoder enters the appropriate mode based on the state of the ENC_SEL line.

The transcoder then sets the baud rate according to the state of the SEL_BAUD line and goes to sleep until an action on one of its inputs places it into another mode.

In summary, there are two key points in the initial operation of the transcoders:

- Prior to Create Mode, all of the status lines will be either inputs or outputs depending on the state of the ENC_SEL line when the transcoder is powered on
- Prior to Learn Mode, any valid MS or MT style packet will activate the status line outputs

From left to right on page 14:
Figure 9: MT Series Mode Definitions
Figure 10: MT Series Transcoder Restore Default Serial Interface Engine Command
Figure 11: MT Series Transcoder Serial Interface Engine Timings (mS)

MT Series Mode Definitions

Set-Up	Power-Up State	Mode	Description	User Access	Description
Default (From Factory)	ENC_SEL is High	Default Encoder Mode	All status lines are inputs, default address	Open (From Factory)	Any valid packet activates outputs
	ENC_SEL is Low	Default Decoder Mode	All status lines are outputs	Locked (After Learn Mode)	Only authorized users are allowed
Defined (After Create Mode)	ENC_SEL is High	Defined Encoder Mode	Encoder only using defined inputs and address		
	ENC_SEL is Low	Transcoder Mode	Transcoder using defined inputs, outputs and address	Open (From Factory)	Any valid packet activates outputs
				Locked (After Learn Mode)	Only authorized users are allowed

MT Series Transcoder Restore Default Serial Interface Engine Command

Definition	Command	Reply
Restore Default	0x00 - 0xFF - 0x52 - 0x73 - 0x74 0x4D - 0x54 - 0xFF	0x00 - 0x41 - 0x43 - 0x4B - 0xFF

MT Series Transcoder Serial Interface Engine Timings (mS)

Definition	SER_IO = Input				SER_IO = Output				
	Min Ready	Max Ready	Receive Cmd	Process Cmd	Reply Wait	Transmit Reply	Finish Process	Min Total Time	Max Total Time
Restore Default (9,600bps)	0.08	33.00	8.30	1.07	4.00	5.29	870.00	890.00	925.00
Restore Default (28,800bps)	0.08	17.00	2.80	1.07	4.00	1.73	870.00	880.00	900.00

Create Mode

Create Mode allows the generation of a unique address to ensure the uniqueness of a transmission and prevent unintentional operation of devices. The MT Series transcoder allows for the creation of 16,777,216 (2^{24}) possible addresses. The assignment of the status lines as inputs or outputs also occurs in this mode.

Create Mode is entered by pulling the CRT/LRN line high while the ENC_SEL line is high. The address is randomized for as long as the CRT/LRN line is high (the ENC_SEL line is not checked again once the process is begun). Once the line is pulled low, the resulting address is saved in memory and the transcoder is ready to accept the status line assignments. Each line that is to be an input should be pulled high. Any lines not taken high are set as outputs. There is no requirement for the order in which the lines are activated or the time between activations as long as all of the desired lines are activated within the time out period. The transcoder saves the assignments and goes to sleep when the CRT/LRN line is taken high again or when it times out after 15 seconds.

Learn Mode

In order for the transcoder to accept transmissions from a specific transcoder, it must first learn that transcoder's address. This is done by taking the CRT/LRN line high then low while the ENC_SEL line is low to place the transcoder into Learn Mode. Once in Learn Mode, the MODE_IND line starts switching, allowing for connection of a LED to provide visual indication that the transcoder is ready to accept a new address. This continues until the CRT/LRN line goes high again or until a time-out after 15 seconds.

The transcoder looks for a valid transmission from another transcoder and records the received address. It also records the status line that was activated in the Control Permissions. Each status line on the transmitting side that will be authorized to control the receiving transcoder needs to be activated. The receiving transcoder updates the Control Permissions with each valid packet that contains a new active status line. It is not necessary to hold all of the desired status lines on the transmitting side high at the same time, simply press each one that is to be authorized within the time out period. When the CRT/LRN line is taken high again or the transcoder times-out after 15 seconds, the recorded address and Control Permissions are saved in memory and the transcoder returns to sleep.

The MT Series transcoder can store up to sixty unique addresses in its memory. If a transcoder is re-learned, its permissions are overwritten. The transcoder does not create a second instance of the same address. If a new transcoder is learned while the memory is full, then the transcoder writes the new address over the first address in memory. It flashes the MODE_IND line five times to indicate that the memory is full and the next address learned will overwrite the first. All of the learned addresses are retained if power is removed from the transcoder.

If the CRT/LRN line is held high for ten seconds while the ENC_SEL line is low, then the transcoder erases all of the stored addresses from memory. The MODE_IND line goes high for as long as the CRT/LRN line is high, but after the ten seconds it goes low. Once the CRT/LRN line is pulled low again, the MODE_IND line goes high for two seconds to indicate that the memory has been cleared.

Transmit Mode

When any of the status lines that are set as inputs go high, the transcoder enters Transmit Mode. It pulls the TR_PDN line high to activate the transceiver, pulls the TR_SEL line high to place the transceiver into transmit mode, records the states of the status lines, assembles the packet, and sends it through the TR_DATA line. The transcoder then pulls the TR_SEL line low to place the transceiver into receive mode and looks for a confirmation from the remote transcoder. If a valid confirmation is received, then the transcoder pulls the CONFIRM line high, otherwise it checks to see if any status line inputs are high.

The transcoder continues this for as long as any of the status line inputs are high, updating the states of the status lines with each transmission. Once all of the input lines are pulled low, the transcoder finishes the current transmission, pulls CONFIRM and TR_PDN low to deactivate the transceiver, and goes to sleep.

The MT has the ability to control the status line byte through the SIE. An external microcontroller or PC can be used to write the desired input states and a packet counter into the transcoder. The transcoder uses this byte instead of looking at the status line inputs, sends the specified number of packets, then goes to sleep. This is subject to the I/O settings, so lines set as outputs cannot be set high.

Receive Mode

When a rising edge is seen on the TR_DATA line, the transcoder enters Receive Mode. It then looks for a valid packet, meaning that there are no errors and that the received address matches one that is saved in memory. In addition, if Targeted Device Addressing is enabled, then the received targeted address must match the transcoder's local address. If no valid data is received within 16 or 32mS (dependent on the selected baud rate) then Receive Mode is exited. If there is a match, then the transcoder pulls the MODE_IND line high as an indication that a valid signal was received. It compares the received commands to the Control Permissions associated with the transcoder that sent the signal, and reproduces the states of the authorized status lines on the originating transcoder on its own status lines. If Confirmation is enabled, the transcoder then pulls the TR_SEL line high to place the transceiver into transmit mode and sends a confirmation to the originating transcoder. It also outputs the ID of the originating transcoder, a Command Byte that represents the states of the status lines, and a custom data byte programmed by the user. It then looks for the next valid data packet. If, at any time, an error or an unknown address is detected, then the transcoder ignores the packet and looks for the next one. If the 131mS timer runs out before any valid packets are received, then the transcoder goes back to sleep.

TX ID

The transcoder outputs an eight-bit binary number on the SER_IO line to identify which learned transcoder sent the transmission. The number normally corresponds to the order in which the transcoder was learned, so the first transcoder learned will get number '1', the second will get number '2', and so on. An exception arises when the memory is full, in which case the first numbers are overwritten as described in the Learn Mode section. An exception also arises if the serial interface is used to write an address to a specific location in memory. The TX ID is output with the Status and Custom Data bytes after every valid packet that is received, as described in the Serial Output section.

LATCH Mode

The transcoder has two output options based on the state of the LATCH line. If the line is low, then all of the status line outputs will be momentary, meaning that they will only be high for as long as a valid signal is received. Once the signal stops and the transcoder times out, the lines are pulled low.

If the LATCH line is high, then the transcoder will use a Latch Mask on the outputs. By default, all of the status line outputs are set to latch, so the transcoder will pull a data line high upon reception of a valid signal and hold it high until the signal is received a second time, at which point the transcoder will pull it low. The transcoder must see a break and time out of Receive Mode between valid transmissions before it will toggle the outputs.

The Latch Mask can be changed through the SIE so that individual status lines can be set as latched or momentary. The Serial Mode section has more information on the SIE.

Targeted Device Addressing

One of the powerful features of the MT is Targeted Device Addressing. This is the ability to target the specific device that is to acknowledge the transmission. This is accomplished by entering the address of the target device through the SIE. For example, if a master controller needs Device 10 to activate, a microcontroller or PC can be used to program the address of Device 10 into the transcoder in the master controller. The transcoder will then broadcast that address with the commands, and only Device 10 will respond. This enables many types of master-slave, peer-to-peer, and even basic networking systems to be quickly realized. The simple command set and open architecture allow such systems to be implemented in many ways. Application Note AN-00157 goes into this feature in more detail.

Targeted Device Addressing only needs to be enabled on the transmitting side. The receiving side identifies the packet as a targeted packet and responds appropriately. This option is disabled by default.

Custom Data Transmission

The MT Series offers the option of sending one byte of custom data with the command packet. The custom byte is entered into the transcoder through the SIE using the Read and Write Custom Data Value commands. This option is enabled or disabled using the Enable and Disable Custom Data commands. The custom data byte is output on the receiving end with the TX ID and Status bytes. Custom Data Transmission only needs to be enabled on the transmitting side. The receiving side identifies the packet as containing custom data and outputs the byte. This option is disabled by default and the receiving transcoder outputs a value of 0xFF for the custom byte.

This feature is useful for sending an 8-bit A/D value from a sensor, custom command codes, or an additional user-defined ID for additional proprietary system authentication. There are no restrictions on the 8-bit value, though 0xFF is not recommended for use since that is the default value with no data.

The Custom Data is output with the Status and TX ID bytes, as described in the Serial Output section.

Mode Entry Timings

The transcoder may enter the desired mode within minimum timings shown in the figure below. However, if the transcoder is in another mode at the time the CRT/LRN line goes high, then it could take longer for the transcoder to recognize the trigger. For example, Receive Mode at 9,600bps can take 32mS to exit. For this reason, it is recommended to increase the time to ensure that the transcoder will enter the correct mode. Typical times are shown in the figure, but may be adjusted according to the application.

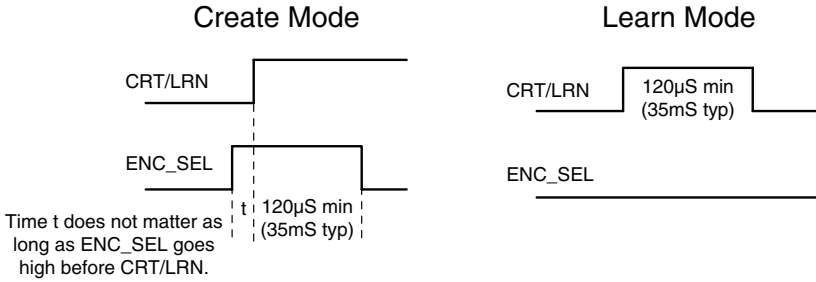

Figure 12: MT Series Mode Entry Timings

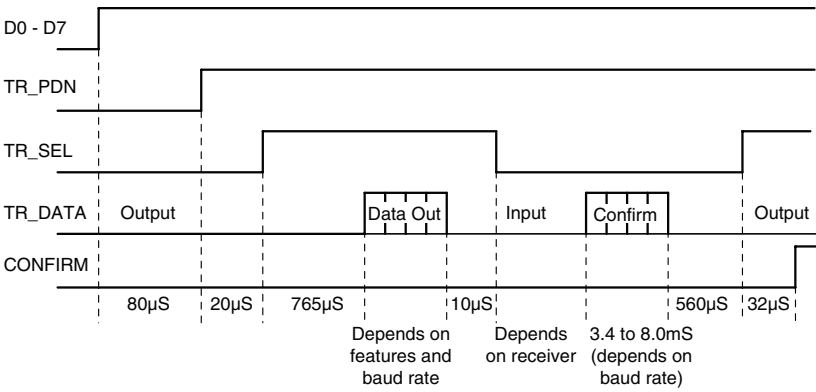

Figure 13: MT Series Transmit Timings

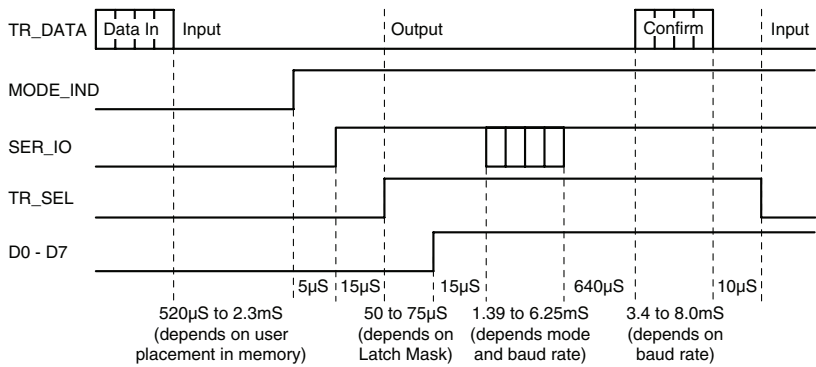

Figure 14: MT Series Receive Timings

Serial Output

Upon reception of every valid packet, the transcoder outputs a serial data stream containing information about the transmission. The information takes two forms depending on the User Access setting.

If the User Access is set to open, then the serial output consists of a start byte, the three byte address of the transmitting device, a status line byte, a custom data byte and a stop byte. The start byte is 0x00 and the stop byte is 0xFF.

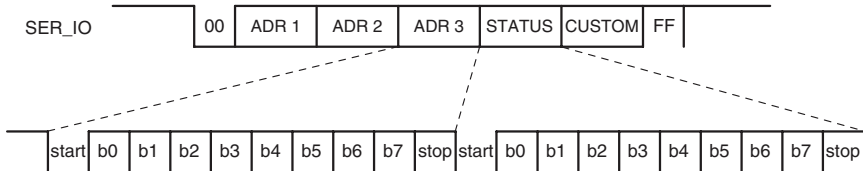

Figure 15: MT Series Transcoder Open Access Serial Output

If the User Access is set to locked, then the serial output consists of a start byte, TX ID byte, status line byte, custom data byte and a stop byte. The start byte is 0x00 and the stop byte is 0xFF.

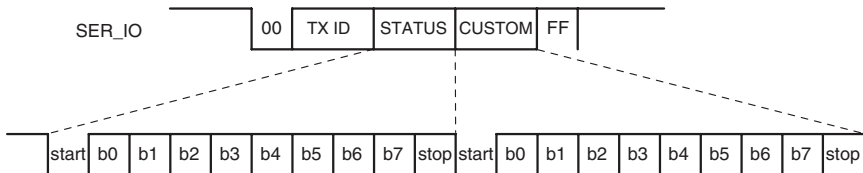

Figure 16: MT Series Transcoder Locked Access Serial Output

The status line byte reflects the states of the status lines, '1' for high and '0' for low. This represents the current logic states of the outputs, not the command that was received, so that the states of latched lines are correctly represented. Line D0 corresponds to bit b0 in the byte, D1 corresponds to b1, and so forth. This allows applications that use an embedded microcontroller to read the transmitted commands without having to monitor eight hardware lines.

The TXID and Custom Data bytes are described in their own sections.

The bytes are output asynchronously least significant bit first with one start bit, one stop bit, and no parity at the baud rate determined by the SEL_BAUD line. During normal operation, the SER_IO line is an input,

becoming an output only when sending the data stream or responding to a serial command. These are described more in the Serial Interface section. Application Note AN-00157 shows some example software to read the TX ID and associate it with a particular transcoder.

This feature is useful in applications that need to track and record activation attempts. The transcoder validates that the command is from an authorized transmitter and an external microcontroller or PC can record the TX ID and status line activation and time into a log. The Custom byte can also be used as an additional validation or to send a sensor reading that also needs to be logged.

Serial Mode

One of the most powerful features of the MT Series is its Serial Interface Engine (SIE). The SIE allows the user to monitor and control the device configuration settings through an automated system or PC rather than manually through the hardware lines. While serial programming is not required for basic operation, it enables the advanced features offered by the MT, such as Targeted Device Addressing and Custom Data transmissions.

The SIE consists of twenty commands. The transcoder outputs an acknowledgement once it has received each command, and then a response of up to four additional bytes if required by the command.

Serial Mode is entered by taking the CRT/LRN line high while the SER_IO line is high. The MODE_IND line goes high for as long as the SER_IO line is an output, allowing it to be used with RS-232 style handshaking. Each byte is sent LSB first with one start bit, one stop bit, and no parity at the baud rate determined by the SEL_BAUD line. After the last command byte is received, there will be a 1mS pause while the SER_IO line is changed to an output, then a 4mS pause while the transcoder processes the command. Then it outputs the acknowledgement and a response if appropriate. The SER_IO line is changed to an input as soon as the MODE_IND line drops after the acknowledgement is sent. The figure below shows the order and timing of the serial interface.

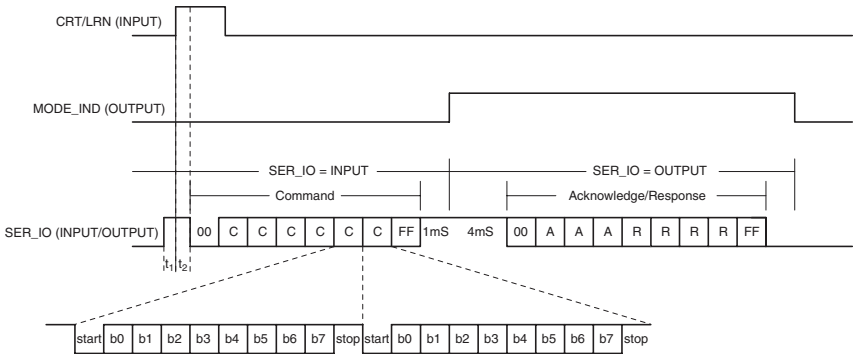

Figure 17: MT Series Transcoder Serial Programming

Time t1 in the figure above does not have to be any specific time, just so long as the SER_IO line goes high before the CRT/LRN line. Time t2 should be greater than 120µS (typical of 35mS, see the Mode Entry Timings section) to ensure that the transcoder goes into Serial Mode. There is not a maximum time specified. Once in Serial Mode, the transcoder waits for the start byte (0x00) of the serial command.

The timings associated with each command and the transcoder's response are listed in Tables 7 (9,600bps) and 8 (28,800bps).

To send consecutive commands, keep the CRT/LRN line high and take the SER_IO line high within 50µS of the MODE_IND line going low.

It should be noted that all of the settings are written into non-volatile memory, so they will be retained if power is removed from the chip. This includes all values, such as custom byte and target address, as well as the enabled / disabled states.

Serial Interface Command Set Definitions

There are ten functions using the Serial Interface Engine (SIE). Each function has the ability to read the current setting from the MT or write new information to the specified configuration setting.

Serial Interface Command Set Definitions	
Command	Description
Local Settings	Reads and writes the device's local 24-bit address and status line configuration. This allows the option to program all devices with the same address and status line configuration, or increment the address to utilize the full range of addresses.
Next User ID	Reads and writes the next available ID location, which will be given to the next user manually learned into the system.
Specific User	Reads and writes the 24-bit address and status line configuration for a specific user learned into the system. If a device in the system is lost or stolen, that specific device can be removed from the system and replaced with a new one without having to erase the memory and re-learn all of the other devices in the system. To remove an existing user, write 0xFF into the address and status line values. 0xFF should not be used as a learned user.
Target Address	Reads and writes the local device's 24-bit target address. This allows a user to communicate directly with a specified target device and not with any other devices even though they may have been authorized for communication.
Custom Data Value	Reads and writes a single byte that is sent when Custom Data is enabled. If enabled, the byte will be sent with each packet, and then output on the SER_IO line of the receiving device along with the TX ID value and the status line value.
Latch Mask	Reads and writes the Latch Mask for the status line outputs. This allows each status line to be individually set as momentary or latched.
Status Value	Reads the current state of the transcoder's status line outputs. Writes the value of the status line inputs to be sent (subject to I/O mask) and the number of packets to send.
Confirmation EN	Reads and writes the device's confirmation enable setting. When enabled, the receiving transcoder will immediately transmit a confirmation packet back to the originating transcoder. The originating transcoder will validate the confirmation and then activate its CONFIRM line. If the confirmation is not necessary or the user wants to free the air of additional transmissions, confirmation can be disabled and the receiving device will not transmit a confirmation packet.
Targeting EN	Reads and writes the device's target enable setting. This enables or disables the option for the transcoder to send a targeted data packet.
Custom Data EN	Reads and writes the transcoder's custom data setting. This enables or disables the option for the transcoder to send a custom data byte with each transmission.

Figure 18: Serial Interface Command Set Definitions –23–

Serial Interface Connections

The serial interface on the MT Series can be connected to any device capable of serial communication, including microcontrollers, RS-232 drivers and computers. The figure below gives an example of connecting the MT to the Linx QS Series USB module for connection to a computer.

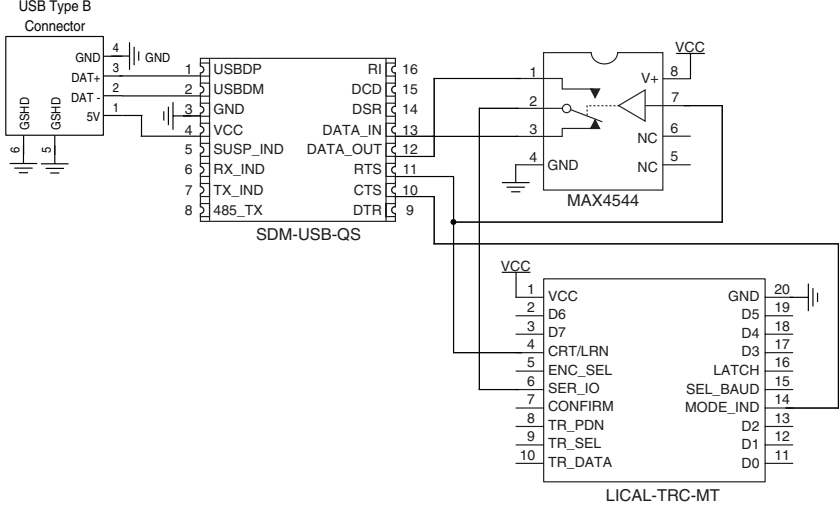

Figure 19: MT Series Transcoder Serial Interface to a PC

The USB module follows the RS-232 convention of using separate lines for data input and data output while the transcoder has a single line for all data. This requires a switch to alternatively connect the transcoder’s SER_IO line to the data lines on the module.

The RTS line is used to throw the switch as well as to activate the CRT/LRN line placing the transcoder into Serial Mode. This gives the PC the ability to control when communication is initiated.

The MODE_IND line will go high when the transcoder is prepared to send data, so the CTS line on the USB module is used to monitor the MODE_IND line. This allows the computer to know when to throw the switch and look for data from the transcoder.

One point of note is that voltage translation may be necessary if the 5V USB module is used to communicate with a transcoder operating at 3V. There are many components and methods for implementing level shifting, so it is up to the designer to determine the best solution for the product.

MT Series Transcoder Serial Interface Engine Command Set		
Definition	Command	Reply
Read Local Settings	0x00 - 0x01 - 0x00 - 0x00 - 0x00 - 0x00 - 0x00 - 0xFF	0x00 - 0x41 - 0x43 - 0x4B - A1 - A2 - A3 - IOs - 0xFF
Write Local Settings	0x00 - 0x02 - A1 - A2 - A3 - IOs - 0x00 - 0xFF	0x00 - 0x41 - 0x43 - 0x4B - 0xFF
Read Next User ID	0x00 - 0x11 - 0x00 - 0x00 - 0x00 - 0x00 - 0x00 - 0xFF	0x00 - 0x41 - 0x43 - 0x4B - ID - 0xFF
Write Next User ID	0x00 - 0x12 - ID - 0x00 - 0x00 - 0x00 - 0x00 - 0xFF	0x00 - 0x41 - 0x43 - 0x4B - 0xFF
Read Specific User	0x00 - 0x21 - ID - 0x00 - 0x00 - 0x00 - 0x00 - 0xFF	0x00 - 0x41 - 0x43 - 0x4B - A1 - A2 - A3 - CP - 0xFF
Write Specific User	0x00 - 0x22 - A1 - A2 - A3 - CP - ID - 0xFF	0x00 - 0x41 - 0x43 - 0x4B - 0xFF
Read Target Address	0x00 - 0x31 - 0x00 - 0x00 - 0x00 - 0x00 - 0x00 - 0xFF	0x00 - 0x41 - 0x43 - 0x4B - A1 - A2 - A3 - 0xFF
Write Target Address	0x00 - 0x32 - A1 - A2 - A3 - 0x00 - 0x00 - 0xFF	0x00 - 0x41 - 0x43 - 0x4B - 0xFF
Read Custom Data Value	0x00 - 0x41 - 0x00 - 0x00 - 0x00 - 0x00 - 0x00 - 0xFF	0x00 - 0x41 - 0x43 - 0x4B - Data - 0xFF
Write Custom Data Value	0x00 - 0x42 - Data - 0x00 - 0x00 - 0x00 - 0x00 - 0xFF	0x00 - 0x41 - 0x43 - 0x4B - 0xFF
Read Latch Mask Value	0x00 - 0x51 - 0x00 - 0x00 - 0x00 - 0x00 - 0x00 - 0xFF	0x00 - 0x41 - 0x43 - 0x4B - Mask - 0xFF
Write Latch Mask Value	0x00 - 0x52 - Mask - 0x00 - 0x00 - 0x00 - 0x00 - 0xFF	0x00 - 0x41 - 0x43 - 0x4B - 0xFF
Read Status Outputs	0x00 - 0x61 - 0x00 - 0x00 - 0x00 - 0x00 - 0x00 - 0xFF	0x00 - 0x41 - 0x43 - 0x4B - Outputs - 0xFF
Write Status Inputs	0x00 - 0x62 - Status - Packets - 0x00 - 0x00 - 0x00 - 0xFF	0x00 - 0x41 - 0x43 - 0x4B - 0xFF
Read Confirmation EN	0x00 - 0x71 - 0x00 - 0x00 - 0x00 - 0x00 - 0x00 - 0xFF	0x00 - 0x41 - 0x43 - 0x4B - VAL - 0xFF
Write Confirmation EN	0x00 - 0x72 - VAL - 0x00 - 0x00 - 0x00 - 0x00 - 0xFF	0x00 - 0x41 - 0x43 - 0x4B - 0xFF
Read Device Targeting EN	0x00 - 0x81 - 0x00 - 0x00 - 0x00 - 0x00 - 0x00 - 0xFF	0x00 - 0x41 - 0x43 - 0x4B - VAL - 0xFF
Write Device Targeting EN	0x00 - 0x82 - VAL - 0x00 - 0x00 - 0x00 - 0x00 - 0xFF	0x00 - 0x41 - 0x43 - 0x4B - 0xFF
Read Custom Data EN	0x00 - 0x91 - 0x00 - 0x00 - 0x00 - 0x00 - 0x00 - 0xFF	0x00 - 0x41 - 0x43 - 0x4B - VAL - 0xFF
Write Custom Data EN	0x00 - 0x92 - VAL - 0x00 - 0x00 - 0x00 - 0x00 - 0xFF	0x00 - 0x41 - 0x43 - 0x4B - 0xFF

A1, A2, A3 = 8-bit values totaling 24-bit address
 IOs = Status line input/output settings (0 = output, 1 = input; line D0 corresponds to bit b0)
 ID = User ID value (decimal notation, 1 to 60)
 CP = Control permissions for the learned transcoder (0 = not authorized, 1 = authorized; line D0 corresponds to bit b0)
 Data = value of custom data byte transferred when the option is enabled
 Mask = value used to define which outputs are latched when Latch Mode is enabled (0 = momentary, 1 = latched; line D0 corresponds to bit b0)
 Outputs = Current state of the status line outputs (0 = low, 1 = high; line D0 corresponds to bit b0)
 Packets = Number of packets to be sent
 VAL = Option enable value (0x00 = OFF, 0x01 = ON)
 To delete a specific user, perform a Write Specific User operation with A1, A2, A3, and IOs set to 0xFF

MT Series Transcoder Activation Times and Transmitted Packet Duty Cycle

Definition	Custom Data Transmission	Targeted Device Addressing	Baud Rate (bps)	Packet Time (mS)	Min Activation Time (mS)	Max Activation Time (mS)	TX Data Duty Cycle (%)
Off	Off	Off	9,600	20.0	9.6	337.6	22.0
Off	Off	Off	28,800	11.3	5.0	170.0	18.6
On	Off	Off	9,600	23.0	9.6	337.6	19.1
On	Off	Off	28,800	11.0	5.0	170.0	19.1
Off	On	Off	9,600	21.3	11.0	339.0	23.2
Off	On	Off	28,800	11.9	5.7	170.7	19.3
On	On	Off	9,600	24.4	11.0	339.0	20.3
On	On	Off	28,800	11.6	5.7	170.7	19.8
Off	Off	On	9,600	23.8	13.8	341.8	25.6
Off	Off	On	28,800	12.9	7.0	172.0	20.9
On	Off	On	9,600	27.2	13.8	341.8	22.4
On	Off	On	28,800	12.9	7.0	172.0	20.9
Off	On	On	9,600	25	15.1	343.1	26.6
Off	On	On	28,800	13.4	7.6	172.6	21.6
On	On	On	9,600	28.6	15.1	343.1	23.3
On	On	On	28,800	13.6	7.6	172.6	21.3

Minimum Activation time without Transceiver Power Control
 Maximum Activation time with Transceiver Power Control

Figure 21: MT Series Transcoder Activation Times and Transmitted Packet Duty Cycle

Figure 22: MT Series Transcoder Serial Interface Engine Timings (mS) at 9,600bps

MT Series Transcoder Serial Interface Engine Timings (mS) at 9,600bps									
Definition	SER_IO = Input					SR_IO = Output			
	Min Ready	Max Ready	Receive Cmd	Process Cmd	Reply Wait	Transmit Reply	Finish Process	Min Total Time	Max Total Time
Read Local Settings	0.08	33.00	8.30	1.11	4.00	9.58	0.04	23.11	56.03
Write Local Settings	0.08	33.00	8.30	1.03	4.00	5.29	17.89	36.59	69.51
Read Next User ID	0.08	33.00	8.30	1.06	4.00	6.38	0.04	19.86	52.78
Write Next User ID	0.08	33.00	8.30	1.04	4.00	5.29	3.65	22.36	55.28
Read Specific User	0.08	33.00	8.30	1.11	4.00	9.58	0.04	23.11	56.03
Write Specific User	0.08	33.00	8.30	1.04	4.00	5.29	14.30	33.05	65.93
Read Target Address	0.08	33.00	8.30	1.10	4.00	8.51	0.04	22.03	54.95
Write Target Address	0.08	33.00	8.30	1.05	4.00	5.29	10.74	29.46	62.38
Read Custom Data Value	0.08	33.00	8.30	1.07	4.00	6.38	0.04	19.87	52.79
Write Custom Data Value	0.08	33.00	8.30	1.05	4.00	5.29	3.65	22.37	55.29
Read Latch Mask Value	0.08	33.00	8.30	1.05	4.00	6.38	0.04	19.85	52.79
Write Latch Mask Value	0.08	33.00	8.30	1.06	4.00	5.29	**	18.79	52.29
Read Status Outputs	0.08	33.00	8.30	1.05	4.00	6.38	0.04	19.87	52.77
Write Status Inputs	0.08	33.00	8.30	1.06	4.00	5.29	3.65	22.38	51.71
Read Confirmation EN	0.08	33.00	8.30	1.07	4.00	6.38	0.04	19.87	52.79
Write Confirmation EN	0.08	33.00	8.30	1.06	4.00	5.29	3.65	22.38	52.30
Read Device Targeting EN	0.08	33.00	8.30	1.08	4.00	6.38	0.04	19.88	52.80
Write Device Targeting EN	0.08	33.00	8.30	1.06	4.00	5.29	3.65	22.38	55.30
Read Custom Data EN	0.08	33.00	8.30	1.08	4.00	6.38	0.04	19.88	52.80
Write Custom data EN	0.08	33.00	8.30	1.07	4.00	5.29	3.65	22.39	55.31

MinRdy applies when MT is in Encoder Only mode.
MaxRdy applies when MT is in Transcoder mode and time may be longer due to possible receive timeout period.
Receive Command is calculated for 8-bytes at 9,600bps (104us/bit).
Transmit Reply is measured on the SER_IO pin from the MT
** Finish Process time for the Write Status Inputs command = 0.06mS + (Packet Time * Number of Packets). See Table 3 for Packet Time.

Figure 23: MT Series Transcoder Serial Interface Engine Timings (mS) at 28,800bps

MT Series Transcoder Serial Interface Engine Timings (mS) at 28,800bps									
Definition	SER_IO = Input					SR_IO = Output			
	Min Ready	Max Ready	Receive Cmd	Process Cmd	Reply Wait	Transmit Reply	Finish Process	Min Total Time	Max Total Time
Read Local Settings	0.08	17.00	2.80	1.11	4.00	3.10	0.04	11.13	28.05
Write Local Settings	0.08	17.00	2.80	1.03	4.00	1.73	17.80	27.44	44.36
Read Next User ID	0.08	17.00	2.80	1.06	4.00	2.07	0.04	10.06	26.97
Write Next User ID	0.08	17.00	2.80	1.04	4.00	1.73	3.65	13.30	30.22
Read Specific User	0.08	17.00	2.80	1.11	4.00	3.11	0.04	11.14	28.06
Write Specific User	0.08	17.00	2.80	1.04	4.00	1.73	14.30	23.95	40.87
Read Target Address	0.08	17.00	2.80	1.10	4.00	2.77	0.04	10.79	27.71
Write Target Address	0.08	17.00	2.80	1.05	4.00	1.73	10.74	20.40	37.32
Read Custom Data Value	0.08	17.00	2.80	1.07	4.00	2.08	0.04	10.07	26.99
Write Custom Data Value	0.08	17.00	2.80	1.05	4.00	1.73	3.65	13.31	30.23
Read Latch Mask Value	0.08	17.00	2.80	1.07	4.00	2.08	0.04	10.07	26.99
Write Latch Mask Value	0.08	17.00	2.80	1.05	4.00	1.73	3.65	13.31	30.23
Read Status Outputs	0.08	17.00	2.80	1.05	4.00	2.08	0.04	110.05	26.97
Write Status Inputs	0.08	17.00	2.80	1.06	4.00	1.73	**	9.73	26.65
Read Confirmation EN	0.08	17.00	2.80	1.07	4.00	2.08	0.04	10.07	26.99
Write Confirmation EN	0.08	17.00	2.80	1.06	4.00	1.73	3.65	13.32	30.24
Read Device Targeting EN	0.08	17.00	2.80	1.08	4.00	2.08	0.04	10.08	27.00
Write Device Targeting EN	0.08	17.00	2.80	1.06	4.00	1.73	3.65	13.32	30.24
Read Custom Data EN	0.08	17.00	2.80	1.08	4.00	2.08	0.04	10.08	27.00
Write Custom data EN	0.08	17.00	2.80	1.07	4.00	1.73	3.65	13.33	30.25

MinRdy applies when MT is in Encoder Only mode.
MaxRdy applies when MT is in Transcoder mode and time may be longer due to possible receive timeout period.
Receive Command is calculated for 8-bytes at 928,800bps (34us/bit).
Transmit Reply is measured on the SER_IO pin from the MT
** Finish Process time for the Write Status Inputs command = 0.06mS + (Packet Time * Number of Packets). See Table 3 for Packet Time.

Transcoder MODE_IND Definitions

The MODE_IND line is the primary means of indicating the state of the transcoder to the user. The table below gives the definitions of the MODE_IND signals.

MT Series Transcoder MODE_IND Definitions	
MODE_IND Signals	Description
Receive Mode	ON for as long as the transcoder is receiving data from a learned user. This only indicates authorized data reception, not status output activation.
Create Address Mode	ON during address generation, while CRT/LRN line is HIGH, then it flashes* when CRT/LRN line is taken LOW. Once the 15-second timer expires or the CRT/LRN line is asserted again, the MODE_IND line will turn OFF.
Learn Mode	ON while CRT/LRN line is held HIGH until taken LOW to enter Learn Mode, then it flashes* for 15 seconds until the timer expires or the CRT/LRN line is asserted again. If the 60th user profile has been saved, it will blink* 5 times to indicate the next user profile will overwrite the first.
Erase Mode	ON while CRT/LRN line is held HIGH for 10 seconds and Erase Mode is entered, then it turns OFF until the CRT/LRN line is released. It will then turn back ON again for 2 seconds to indicate erase completion.
Serial Interface Mode	OFF while command is being received (SER_IO = input) and ON while ACK/reply message is being sent (SER_IO = output).

*Blink = ON for 1sec and OFF 250mS
 *Flash = ON for 65mS and OFF for 65mS

Figure 24: MT Series Transcoder MODE_IND Definitions

Legal Considerations

If the transcoder is to be used with a transceiver operating in the 260MHz to 470MHz ISM band in the United States under Part 15.231, then there are some legal requirements that need to be considered. The FCC requires that the transmission control something, so the transcoder cannot be used simply for passing data. The data lines and CONFIRM line must be connected to something that turns on or off, such as a motor, LED, buzzer, or display. Application Note AN-00128 goes into this in detail.

The transcoder has the ability to be automatically activated with the Write Status Inputs command through the SIE. The FCC requires that any automatic transmission cease within 5 seconds of activation. The MT could exceed this time depending on the baud rate used, the options that are enabled, and the number of packets that are sent. Table 3 shows the packet time at each baud rate with the various options enabled or disabled. The designer needs to be aware of the time depending on the options that are in use and adjust the packet counter in the command to ensure that the total time does not exceed 5 seconds. Application Note AN-00157 goes into the serial commands in more detail and Application Note AN-00125 goes into the FCC regulations under Part 15.231.

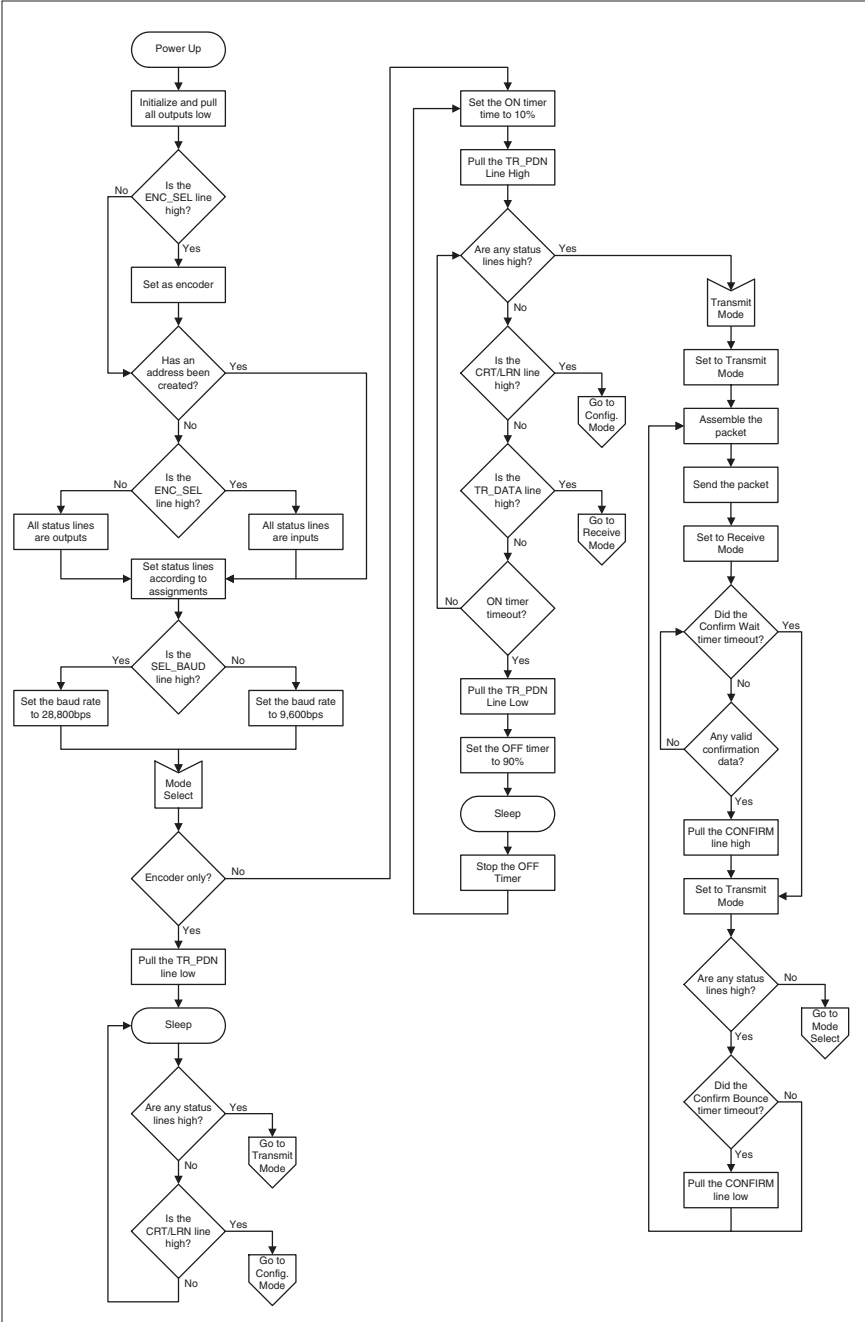

Figure 25: MT Series Transcoder Power-up Flowchart

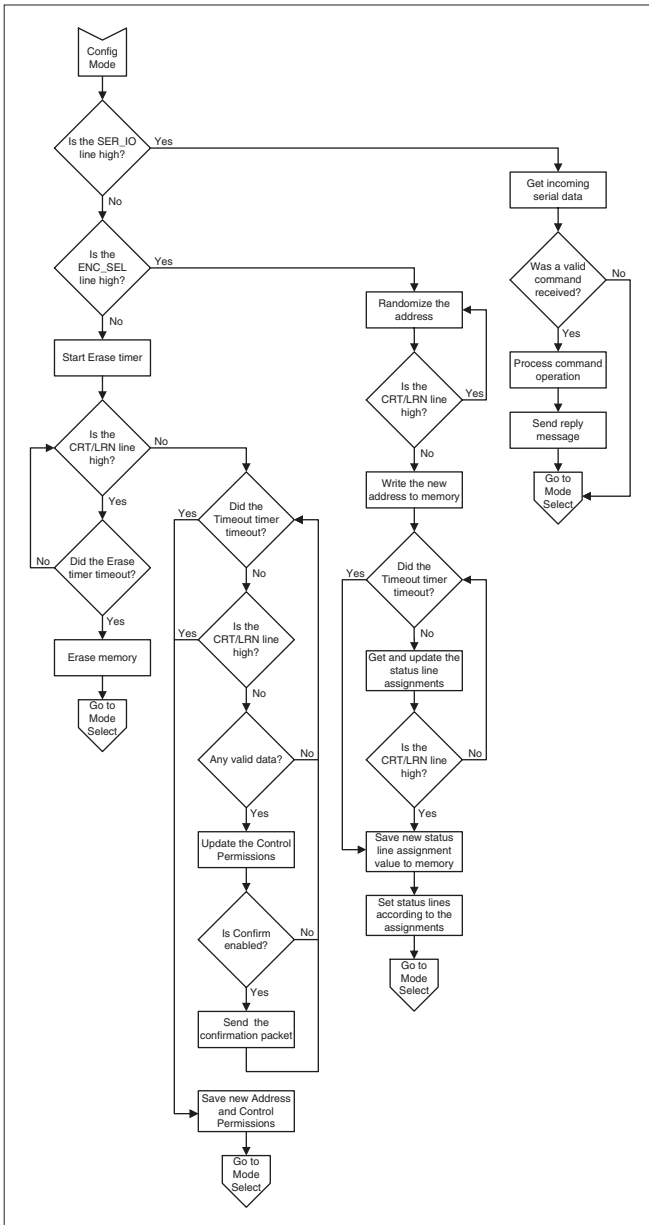

Figure 26: MT Series Transcoder Configure Flowchart

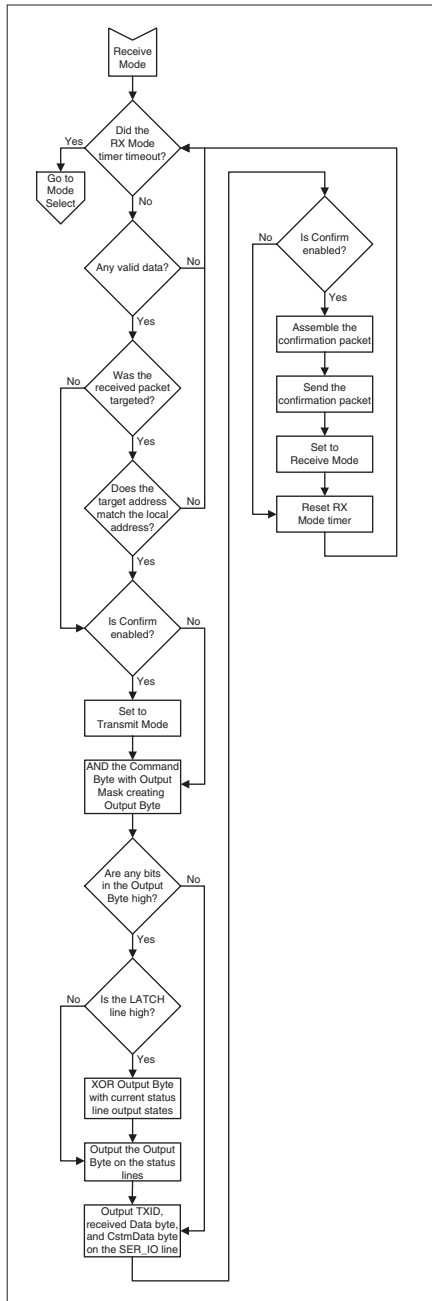

Figure 27: MT Series Transcoder Receive Flowchart

Typical Applications

The MT Series transcoder is ideal for replicating button presses for remote control applications. An example application circuit is shown below.

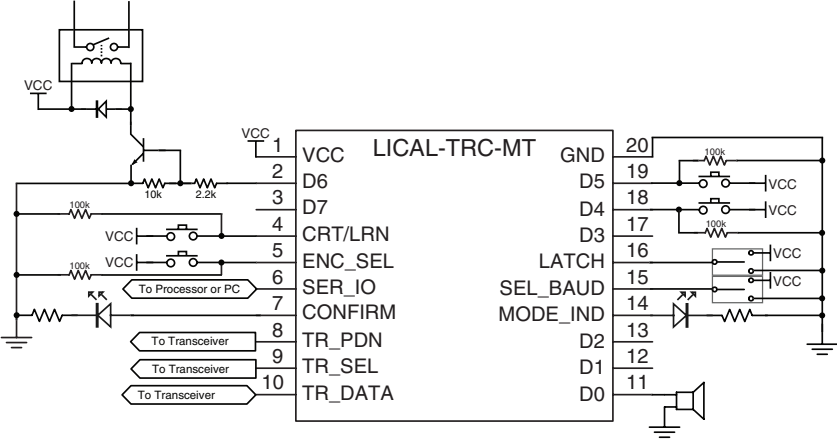

Figure 28: MT Series Transcoder Application Circuit

SPDT switches are used to select the baud rate and set the latch mode. These can be tied directly to supply or ground if they will not change.

The TR_PDN line can be connected to the PDN line of a transceiver or it can be left floating.

SER_IO can be connected to a microprocessor or a PC to program the transcoder through the serial command set or to record the transmitter identity. Application Note AN-00157 has sample code.

A LED indicator is attached to the MODE_IND line to provide visual feedback to the user that an operation is taking place. This line will source a maximum of 25mA, so the limiting resistor may not be needed, depending on the LED chosen and the brightness desired.

The CONFIRM line is connected to a LED to indicate that the remote device successfully received the command.

The CRT/LRN and ENC_SEL lines are connected to buttons that will pull the lines high when pressed. Since the lines do not have internal pull-down resistors, a 100kΩ resistor is used to pull the line to ground when not in use.

The TR_DATA line is connected directly to the data line of the transceiver.

Data Lines D0 through D7 can be individually set up as either inputs or outputs. In this example, D4 and D5 have buttons connected to them, so they will be set up as inputs, and D0 and D6 are set up as outputs. D0 is connected directly to a piezoelectric buzzer. Line D6 will activate a relay through a transistor buffer when it goes high. A buffer like this may be needed if the load requires more than 25mA of current or a higher voltage source to activate. The transcoder will turn on the transistor, which can be selected to provide the appropriate drive levels to activate the relay.

Design Steps to Using the MT Series

Default Use

1. Tie ENC_SEL high on one transcoder to put it into Default Encoder Mode.
2. Tie ENC_SEL low on another transcoder to put it into Default Decoder Mode.
3. Get the received address and command on the SER_IO line.

Note: When used in this manner, the device set in Default Decoder Mode will accept all transmissions, regardless of address. For applications where addressing is not required, this makes setup extremely easy. For applications that need more users than can be provided by the MT, an external controller or PC can be used to create a larger user database. Once a remote address is learned, a valid learned address is required for all transmissions before the transcoder will respond.

Creation of an Address and assignment of status lines

1. Take the CRT/LRN line high while the ENC_SEL line is high to enter Create Mode.
2. The Address will be randomized for as long as the CRT/LRN line is high (the ENC_SEL is not monitored once Create Mode has been entered). The MODE_IND line will go high to indicate that the Address is being randomized.
3. Release the CRT/LRN line and the MODE_IND line will begin switching to indicate that the transcoder is ready to set status line assignments.
4. Take each line that is to be an input high within fifteen seconds.
5. Take the CRT/LRN line high again or let the transcoder time out after fifteen seconds to exit Create Mode.

Learn another transcoder's Address

1. Take the CRT/LRN line high then low while the ENC_SEL line is low to enter Learn Mode.

2. The MODE_IND line will begin switching to indicate that the transcoder is ready to receive a transmission. On the transmitting side, activate each status line that is to be authorized. The transcoder will record the Address and the activated status lines as the Control Permissions.
3. Take the CRT/LRN line high again or let the transcoder time out after fifteen seconds to exit Learn Mode.

Erase all Address in memory

1. Take the CRT/LRN line high while the ENC_SEL line is low and hold for ten seconds.
2. The MODE_IND line will go high when the CRT/LRN line is activated, then go low after ten seconds to indicate that the memory has been erased.

Communicate through the serial interface

1. Take the CRT/LRN line high while the SER_IO line is high to enter Serial Mode.
2. Use a microcontroller or serial interface to write the desired serial command to the transcoder LSB first with 1 start bit, 1 stop bit, and no parity at the baud rate determined by the SEL_BAUD line.
3. Read the acknowledgement and response (if there is one) from the transcoder LSB first with 1 start bit, 1 stop bit, and no parity at the baud rate determined by the SEL_BAUD line.

(This page is intentionally blank.)

Resources

Support

For technical support, product documentation, application notes, regulatory guidelines and software updates, visit www.linxtechnologies.com

RF Design Services

For customers who need help implementing Linx modules, Linx offers design services including board layout assistance, programming, certification advice and packaging design. For more complex RF solutions, Apex Wireless, a division of Linx Technologies, creates optimized designs with RF components and firmware selected for the customer's application. Call +1 800 736 6677 (+1 541 471 6256 if outside the United States) for more information.

Antenna Factor Antennas

Linx's Antenna Factor division has the industry's broadest selection of antennas for a wide variety of applications.

For customers with specialized needs, custom antennas and design services are available along with simulations of antenna performance to speed development. Learn more at www.linxtechnologies.com.





Linx Technologies
159 Ort Lane
Merlin, OR, US 97532

3090 Sterling Circle, Suite 200
Boulder, CO 80301

Phone: +1 541 471 6256
Fax: +1 541 471 6251
www.linxtechnologies.com

Disclaimer

Linx Technologies is continually striving to improve the quality and function of its products. For this reason, we reserve the right to make changes to our products without notice. The information contained in this Data Guide is believed to be accurate as of the time of publication. Specifications are based on representative lot samples. Values may vary from lot-to-lot and are not guaranteed. "Typical" parameters can and do vary over lots and application. Linx Technologies makes no guarantee, warranty, or representation regarding the suitability of any product for use in any specific application. It is Customer's responsibility to verify the suitability of the part for the intended application. At Customer's request, Linx Technologies may provide advice and assistance in designing systems and remote control devices that employ Linx Technologies RF products, but responsibility for the ultimate design and use of any such systems and devices remains entirely with Customer and/or user of the RF products.

LINX TECHNOLOGIES DISCLAIMS ANY AND ALL WARRANTIES OF MERCHANTABILITY AND FITNESS FOR A PARTICULAR PURPOSE. IN NO EVENT SHALL LINX TECHNOLOGIES BE LIABLE FOR ANY CUSTOMER'S OR USER'S INCIDENTAL OR CONSEQUENTIAL DAMAGES ARISING OUT OF OR RELATED TO THE DESIGN OR USE OF A REMOTE CONTROL SYSTEM OR DEVICE EMPLOYING LINX TECHNOLOGIES RF PRODUCTS OR FOR ANY OTHER BREACH OF CONTRACT BY LINX TECHNOLOGIES. CUSTOMER AND/OR USER ASSUME ALL RISKS OF DEATH, BODILY INJURIES, OR PROPERTY DAMAGE ARISING OUT OF OR RELATED TO THE USE OF LINX TECHNOLOGIES RF PRODUCTS, INCLUDING WITH RESPECT TO ANY SERVICES PROVIDED BY LINX RELATED TO THE USE OF LINX TECHNOLOGIES RF PRODUCTS. LINX TECHNOLOGIES SHALL NOT BE LIABLE UNDER ANY CIRCUMSTANCES FOR A CUSTOMER'S, USER'S, OR OTHER PERSON'S DEATH, BODILY INJURY, OR PROPERTY DAMAGE ARISING OUT OF OR RELATED TO THE DESIGN OR USE OF A REMOTE CONTROL SYSTEM OR DEVICE EMPLOYING LINX TECHNOLOGIES RF PRODUCTS.

The limitations on Linx Technologies' liability are applicable to any and all claims or theories of recovery asserted by Customer, including, without limitation, breach of contract, breach of warranty, strict liability, or negligence. Customer assumes all liability (including, without limitation, liability for injury to person or property, economic loss, or business interruption) for all claims, including claims from third parties, arising from the use of the Products. Under no conditions will Linx Technologies be responsible for losses arising from the use or failure of the device in any application, other than the repair, replacement, or refund limited to the original product purchase price. Devices described in this publication may contain proprietary, patented, or copyrighted techniques, components, or materials.