



OEM HANDHELD TRANSMITTER DATA GUIDE

DESCRIPTION

The Linx CMD-HHTX-*** Remote Command Unit is ideal for general-purpose remote control and command applications. As a part of our Holtek encoder-based OEM family, it has been pre-certified for FCC Part-15 compliance, which reduces costs and time to product introduction. Available in 315, 418 (standard) or 433.92MHz, this handheld remote has a transmission range of up to 1,000 feet when combined with the LR Series receiver. The transmitter can be configured with 1 to 8 buttons and the keypad and labeling can be modified to meet specific OEM customer requirements. Selectable addressing provides security and allows the creation of up to 256 distinct transmitter-receiver relationships. The transmission can be decoded using a matching Linx function module, a Linx KH Series receiver / decoder or Linx LR or LT Series receiver paired with a decoder IC or microcontroller. The unit operates from a single 3V CR2032 lithium button cell.

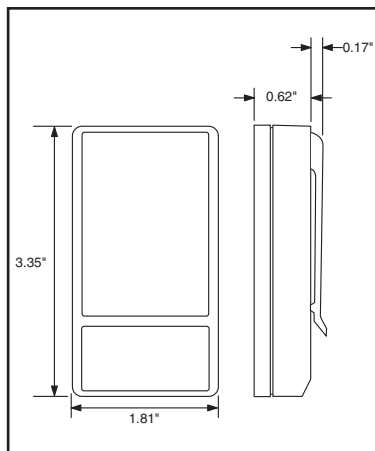

Figure 1: Package Dimensions

FEATURES

- FCC pre-certified
- 1 to 8 buttons
- Small package
- Customizable keypad



OEM Configurations

With a one-time NRE and minimum order, Linx can configure the keypad and label areas to meet your specific requirements. Contact Linx for details.

APPLICATIONS INCLUDE

- General Remote Control
- Keyless Entry
- Garage / Gate Openers
- Lighting Control
- Call Systems
- Home / Industrial Automation

ORDERING INFORMATION

PART #	DESCRIPTION
CMD-HHTX-***-xxx	OEM Handheld Transmitter
EVAL-***-HHTX	HHTX Evaluation Kit

*** = 315, 418 (Standard), 433.92 MHz

ELECTRICAL SPECIFICATIONS

Parameter	Designation	Min.	Typical	Max.	Units	Notes
POWER SUPPLY						
Operating Voltage	V _{CC}	2.1	3.0	3.6	VDC	–
Supply Current	I _{CC}	–	3.4	–	mA	–
Power-Down Current	I _{PDN}	–	5.0	–	nA	1
TRANSMITTER SECTION						
Transmit Frequency Range:	F _C					
CMD-HHTX-315		–	315	–	MHz	–
CMD-HHTX-418		–	418	–	MHz	–
CMD-HHTX-433		–	433.92	–	MHz	–
Center Frequency Accuracy	–	-50	–	+50	kHz	–
ENVIRONMENTAL						
Operating Temperature Range	–	-30	–	+70	°C	1

Notes

1. Characterized, but not tested

THEORY OF OPERATION

The CMD-HHTX-*** OEM Handheld transmitter combines the LC Series transmitter and Splatx planar antenna with an on-board Holtek HT640 encoder IC to form a simple, yet highly reliable, RF remote-control transmitter. The LR Series transmitter is a low-cost, SAW-based ASK / OOK transmitter.

When a button is pressed on the transmitter, power is applied to the internal circuitry and the encoder IC is enabled. The encoder detects the logic states of the address lines and button data lines. These states are formatted into a three-word transmission cycle that continues until the button is released. The encoder data is used to modulate the transmitter, which, through the antenna, conveys the data into free space. On the receiver side, a decoder IC or custom microcontroller is used to check the transmitter's address bits against the address settings of the receiving device. If a match is confirmed, the decoder's outputs are set to replicate the transmitter's button states. These outputs can then be used to activate external circuitry required by the application.

The transmitter is compatible with several Linx receiver products, including the LR, KH2, LT, and OEM product families. For applications where range is critical, the LR Series receiver is the best choice due to its outstanding sensitivity. When the transmitter is combined with an LR Series receiver and the HT658 decoder chip, ranges of up to 1,000 feet are possible. Applications operating over shorter distances will also benefit from the increased link reliability and superior noise immunity provided by the LR Series receiver.

SETTING THE TRANSMITTER ADDRESS

The OEM Handheld transmitter allows the selection of one of 256 unique addresses. All transmitters are supplied set to the same address. To avoid contention with other units or to create unique relationships, the address can be changed. This is accomplished using internal DIP switches as shown. The switches are accessed by removing the rear cover as for battery replacement.

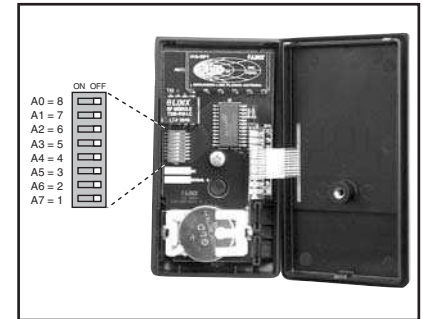

Figure 2: DIP Switch Assignments

If the switch is on, the address line is connected to ground, otherwise it is floating. The receiver's address must match exactly in order for the units to communicate. Application Note AN-00300 describes in detail how to set the address to match any of the receivers offered by Linx. This note can be found in the Support section of the Linx web site, www.linxtechnologies.com.

CMD-HHTX BUTTON ASSIGNMENTS

This diagram illustrates the relationship between the button locations and encoder data lines.

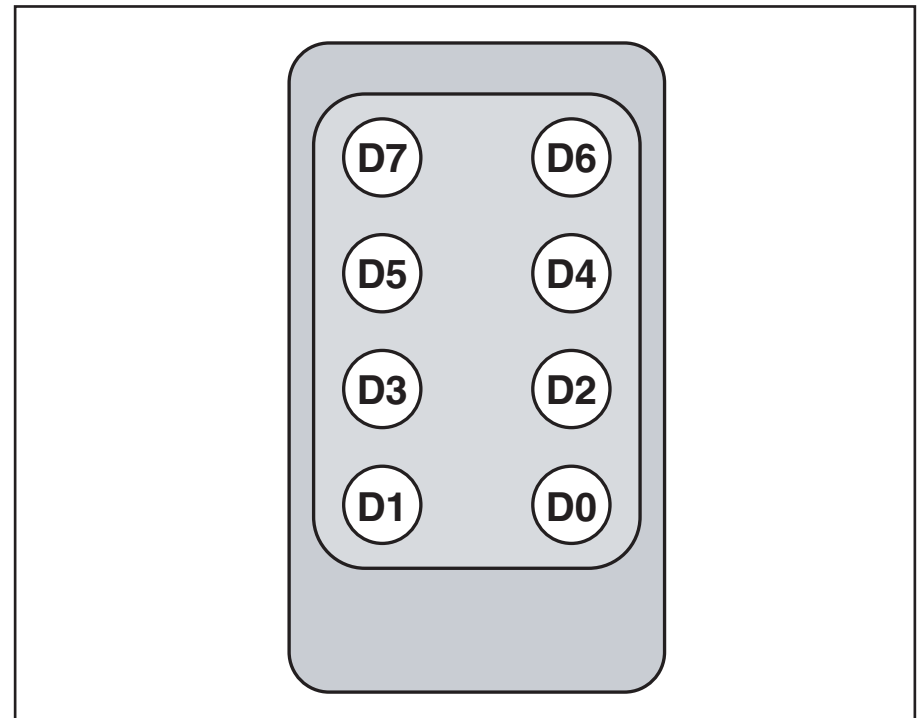

Figure 3: CMD-HHTX-*** Button Assignments

CONTENTION CONSIDERATIONS

It is important to understand that only one transmitter at a time can be activated within a reception area. While the transmitted signal consists of encoded digital data, only one carrier of any particular frequency can occupy airspace without contention at any given time. If two transmitters are activated in the same area at the same time, then the signals will interfere with each other and the decoder will not see a valid transmission, so it will not take any action.

BATTERY REPLACEMENT

The remote unit utilizes a standard CR2032 lithium button cell. In normal use, it will provide 1 to 2 years of operation. To replace the battery, remove the screw in the middle of the back cover. Once the unit is open, remove the battery by depressing the release finger on the battery holder as shown. Replace it with the same type of battery while observing the polarity shown in the adjacent figure.

There may be the risk of explosion if the battery is replaced by the wrong type. Replace it with the same type of battery while observing the polarity shown in the adjacent figure.



Figure 4: Battery Access

ASSEMBLY DIAGRAM

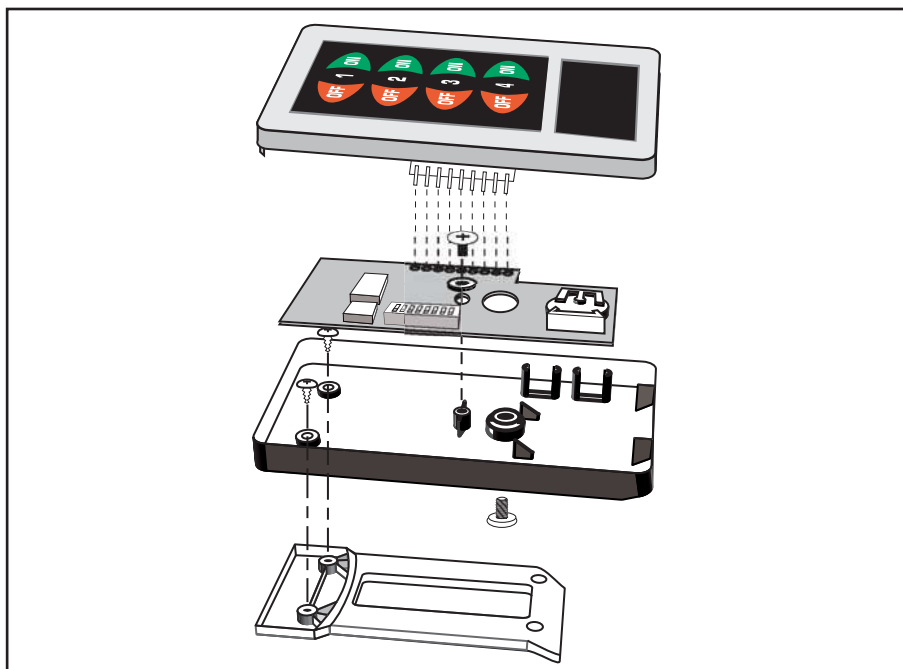

Figure 5: CMD-HHTX-*** Assembly

COMPLIANCE REQUIREMENTS

The CMD-HHTX-*** has been pre-certified by Linx for FCC Part 15 compliance when used with an appropriate function module in keeping with the applications allowed under section 15.231.

LABELING / INSTRUCTION REQUIREMENTS

The CMD-HHTX-*** Handheld transmitter has already been labeled in accordance with FCC regulations in effect as of the date of this document. No further labeling of the unit is needed; however, it is necessary to include the following statement in the end product's instruction manual or insert card for FCC compliance.

INSTRUCTION TO THE USER

This device complies with Part 15 of the FCC Rules.

Operation of this device is subject to the following two conditions:

- (1) This device may not cause harmful interference, and
- (2) this device must accept any interference received, including interference that may cause undesired operation.

This equipment has been tested and found to comply with the limits for a Class B digital device, pursuant to Part 15 of the FCC Rules. These limits are designed to provide reasonable protection against harmful interference in a residential installation. This equipment generates, uses and can radiate radio frequency energy and, if not installed and used in accordance with the instructions, may cause harmful interference to radio communications. However, there is no guarantee that interference will not occur in a particular installation. If this equipment does cause harmful interference to radio or television reception, which can be determined by turning the equipment off and on, the user is encouraged to try to correct the interference by one or more of the following measures:

Reorient or relocate the receiving antenna.

Increase the separation between the equipment and receiver.

Connect the equipment into an outlet on a circuit different from that to which the receiver is connected.

Consult the dealer or an experienced radio/TV technician for help.

This equipment has been certified to comply with the limits for a Class B computing device, pursuant to FCC Rules. In order to maintain compliance with FCC regulations, shielded cables must be used with this equipment. Operation with non-approved equipment or unshielded cables is likely to result in interference to radio and TV reception. The user is cautioned that changes and modifications made to the equipment without the approval of manufacturer could void the user's authority to operate this equipment.

Place the above statement in the instruction manual or insert card.

RECEIVERS

There are four options for receivers within the Linx product line. The first option is to use one of the OEM Function Modules, such as the Relay Module or the AC Wall Module. These items are also pre-certified and can be immediately included in a product.

The other options are to use one of the Linx receiver modules. The signal sent by the OEM Handheld transmitter can be received by the LR Series receiver module or the LT Series transceiver module. These modules can be connected to the Holtek HT658 decoder to decode the signal, or a custom microcontroller can be programmed to decode it and take specific action.

The KH2 Series offers a slightly simpler solution by combining the LR Series receiver and the HT658 decoder in a single package.

When a button is pressed on the transmitter, a corresponding line on the decoder will go high (as long as the addresses match). This can then be connected to whatever circuitry is required by the application.

Application Note AN-00300 discusses in detail how to set the addresses on all of the units. Data guides for all of the receivers, the HT640 encoder, and the HT658 decoder can be found on the Linx Technologies website, www.linxtechnologies.com.



TYPICAL APPLICATIONS

The outstanding sensitivity of the LR Series receiver offers the best range when used with the Handheld transmitter. When using the LR Series receiver, the Holtek HT658 decoder chip should be used to decode the received signal. This decoder has ten address lines that must match the transmitter address lines. A DIP switch is commonly used to set these, but they can also be hardwired. If the address lines match, when a button on the transmitter is pressed a corresponding data line on the decoder (D0-D7) will go high. These data lines can then be connected to external circuitry to perform whatever function is required by the application.

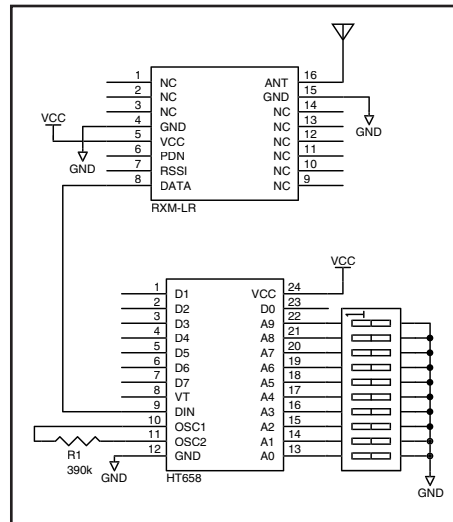

Figure 6: LR Receiver and HT658 Schematic

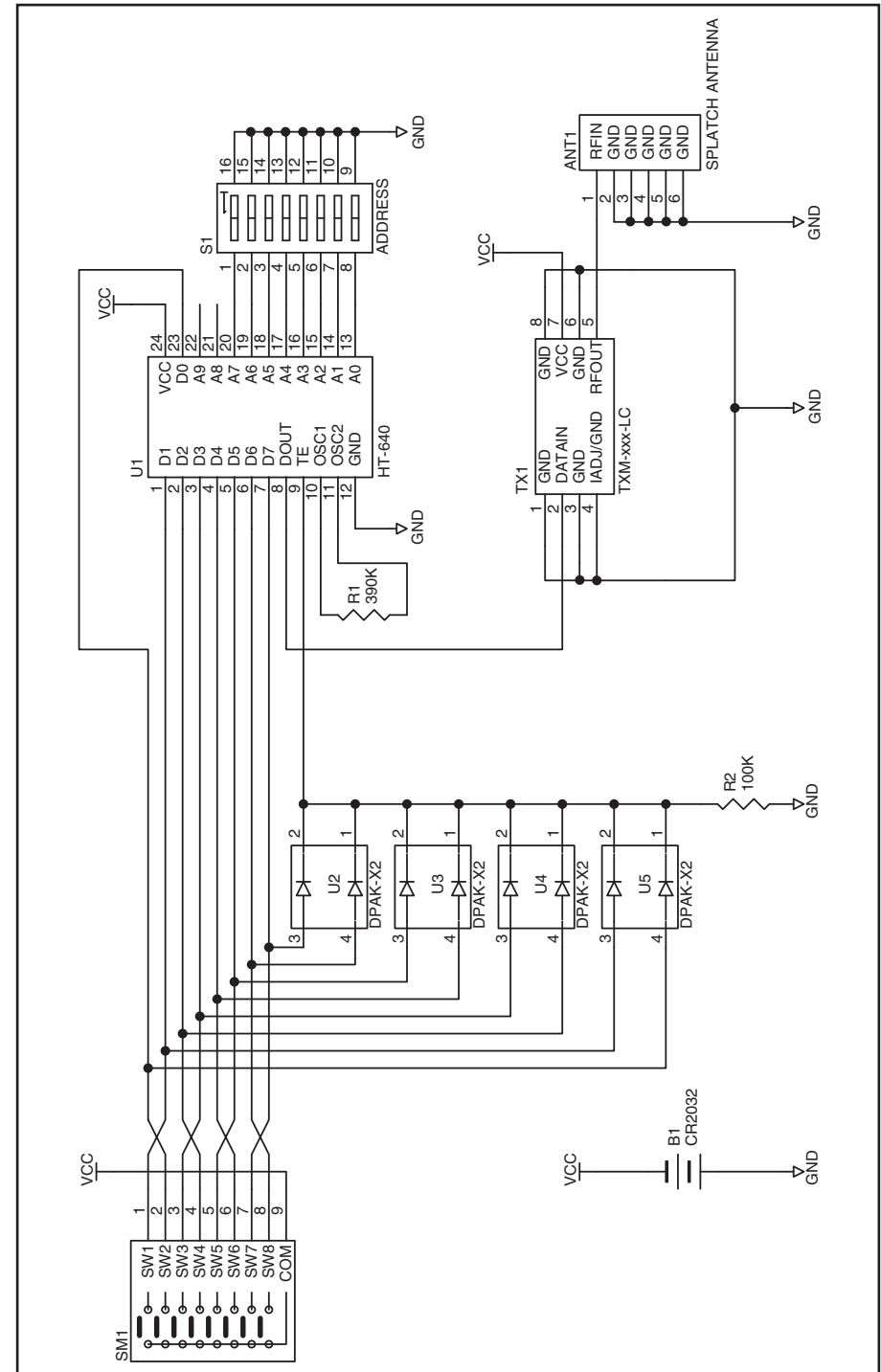

Figure 7: CMD-HHTX-*** Schematic



U.S. CORPORATE HEADQUARTERS

LINX TECHNOLOGIES, INC.

**159 ORT LANE
MERLIN, OR 97532**

PHONE: (541) 471-6256

FAX: (541) 471-6251

www.linxtechnologies.com

Disclaimer

Linx Technologies is continually striving to improve the quality and function of its products. For this reason, we reserve the right to make changes to our products without notice. The information contained in this Overview Guide is believed to be accurate as of the time of publication. Specifications are based on representative lot samples. Values may vary from lot-to-lot and are not guaranteed. "Typical" parameters can and do vary over lots and application. Linx Technologies makes no guarantee, warranty, or representation regarding the suitability of any product for use in any specific application. It is the customer's responsibility to verify the suitability of the part for the intended application. NO LINX PRODUCT IS INTENDED FOR USE IN ANY APPLICATION WHERE THE SAFETY OF LIFE OR PROPERTY IS AT RISK.

Linx Technologies DISCLAIMS ALL WARRANTIES OF MERCHANTABILITY AND FITNESS FOR A PARTICULAR PURPOSE. IN NO EVENT SHALL LINX TECHNOLOGIES BE LIABLE FOR ANY OF CUSTOMER'S INCIDENTAL OR CONSEQUENTIAL DAMAGES ARISING IN ANY WAY FROM ANY DEFECTIVE OR NON-CONFORMING PRODUCTS OR FOR ANY OTHER BREACH OF CONTRACT BY LINX TECHNOLOGIES. The limitations on Linx Technologies' liability are applicable to any and all claims or theories of recovery asserted by Customer, including, without limitation, breach of contract, breach of warranty, strict liability, or negligence. Customer assumes all liability (including, without limitation, liability for injury to person or property, economic loss, or business interruption) for all claims, including claims from third parties, arising from the use of the Products. The Customer will indemnify, defend, protect, and hold harmless Linx Technologies and its officers, employees, subsidiaries, affiliates, distributors, and representatives from and against all claims, damages, actions, suits, proceedings, demands, assessments, adjustments, costs, and expenses incurred by Linx Technologies as a result of or arising from any Products sold by Linx Technologies to Customer. Under no conditions will Linx Technologies be responsible for losses arising from the use or failure of the device in any application, other than the repair, replacement, or refund limited to the original product purchase price. Devices described in this publication may contain proprietary, patented, or copyrighted techniques, components, or materials. Under no circumstances shall any user be conveyed any license or right to the use or ownership of such items.