



MS LONG-RANGE HANDHELD TRANSMITTER DATA GUIDE

DESCRIPTION

The Linx OTX-***-HH-LR8-MS Long-Range Handheld Transmitter is ideal for general-purpose remote control and command applications that require longer transmission distances. This unit has been pre-certified for FCC Part 15, Industry Canada, and European CE (433MHz only) compliance, reducing costs and time to market. Available in 315, 418 (standard), or 433.92MHz, this small remote has a transmission range of up to 1,000 feet when combined with an LR or LT Series module. The transmitter unit can be configured with 1 to 8 buttons and the keypad and labeling can be modified to meet specific OEM customer requirements. Ease of use and security are dramatically enhanced by the on-board MS Series encoder, which allows instant creation of up to 16,777,216 (2^{24}) unique addresses without cumbersome DIP switches or cut traces. When paired with an MS Series decoder, transmitter identity can be determined and button permissions established. The unit uses a single 3V CR2032 lithium button cell.

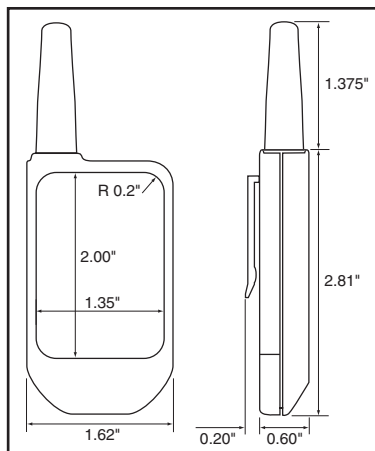

Figure 1: Package Dimensions



FEATURES

- FCC, Canada, and CE pre-certified
- 1 to 8 buttons
- Small package
- Customizable keypad

APPLICATIONS INCLUDE

- General Remote Control
- Keyless Entry
- Garage / Gate Openers
- Lighting Control
- Call Systems
- Home / Industrial Automation
- Wire Elimination

OEM Configurations

With a one-time NRE and minimum order, Linx can configure the keypad and label areas to meet your specific requirements. Contact Linx for details.

ORDERING INFORMATION

PART #	DESCRIPTION
OTX-***-HH-LR8-MS-xxx	MS Long-Range Transmitter
MDEV-***-HH-LR8-MS	HH-LR8 Master Development System
*** = 315, 418 (Standard), 433.92MHz	
xxx = Color Leave blank for standard Black	

ELECTRICAL SPECIFICATIONS

Parameter	Designation	Min.	Typical	Max.	Units	Notes
POWER SUPPLY						
Operating Voltage	V _{CC}	2.1	3.0	3.6	VDC	–
Supply Current	I _{CC}	–	3.4	–	mA	–
Power-Down Current	I _{PDN}	–	5.0	–	nA	1
TRANSMITTER SECTION						
Transmit Frequency Range:	F _C					
OTX-315-HH-LR8-MS		–	315	–	MHz	–
OTX-418-HH-LR8-MS		–	418	–	MHz	–
OTX-433-HH-LR8-MS		–	433.92	–	MHz	–
Center Frequency Accuracy	–	-50	–	+50	kHz	–
ENVIRONMENTAL						
Operating Temperature Range	–	-40	–	+85	°C	1

Notes

1. Characterized, but not tested

THEORY OF OPERATION

The OTX-***-HH-LR8-MS Long-Range Handheld Transmitter combines an LR Series transmitter and an antenna with an on-board MS Series encoder to form a simple, yet highly reliable RF remote-control transmitter. The LR Series transmitter is a low-cost, high-performance synthesized ASK / OOK transmitter. The transmitter's synthesized architecture delivers outstanding stability and frequency accuracy, while minimizing the effects of antenna port loading and mismatching. This reduces or eliminates frequency pulling, bit contraction, and other negative effects that are common to SAW-based transmitter architectures, providing a significantly higher level of performance and reliability.

When a button is pressed on the transmitter, power is applied to the internal circuitry and the encoder is enabled. The encoder then detects the logic states of the button data lines. These states are formatted into a 2-word transmission cycle which continues until the button is released. The encoder data is used to modulate the transmitter which conveys the data into free space through the antenna. Once data is received, a decoder IC is used to check the transmitter's address against an address saved in memory. If a match is confirmed, the decoder's outputs are set to replicate the transmitter's button states. These outputs can then be used to activate external circuitry required by the application.

The transmitter is compatible with the LT and LR product families. For applications where range is critical, the LR Series receiver is the best choice due to its outstanding sensitivity. When the transmitter is combined with an LR Series receiver and an MS Series decoder, ranges of up to 1,000 feet are possible. Applications operating over shorter distances will also benefit from the increased link reliability and superior noise immunity provided by the LR Series receiver.

SETTING THE TRANSMITTER ADDRESS

The MS Long-Range Handheld Transmitter allows the selection of one of 16,777,216 (2^{24}) unique addresses. All transmitters are supplied set to the same address. To avoid contention with other units or to create unique relationships, the address can be changed. This is accomplished by using a paper clip or probe to press the CREATE button on the board through the hole in the back of the case. Press the button and a LED will light up in the MODE_IND window, indicating that the address is being created. The address will be randomized for as long as the button is held down. Release the button and the randomized address will be saved and the LED will begin flashing to indicate that the Control Permissions may now be set. Press the buttons that the transmitter will have the authority to access. Press the CREATE button with the paper clip again or wait 17 seconds for it to time out. The address and Control Permissions are now set. The decoder will need to learn the address before it will accept any transmissions. Please see the Typical Applications section of this data guide or the MS Series Decoder Data Guide for details.



Figure 2: CREATE Button Access

OTX-***-HH-LR8-MS BUTTON ASSIGNMENTS

This diagram illustrates the relationship between the button locations and encoder data lines.

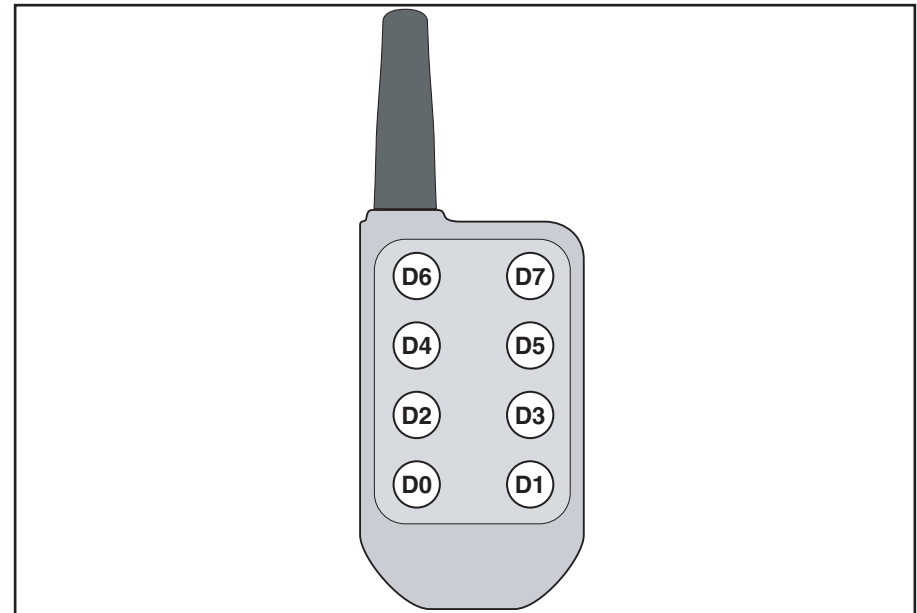

Figure 3: OTX-***-HH-LR8-MS Button Assignments

CONTENTION CONSIDERATIONS

It is important to understand that only one transmitter at a time can be activated within a reception area. While the transmitted signal consists of encoded digital data, only one carrier of any particular frequency can occupy airspace without contention at any given time. If two transmitters are activated in the same area at the same time, then the signals will interfere with each other and the decoder will not see a valid transmission, so it will not take any action.

BATTERY REPLACEMENT

The remote unit utilizes a standard CR2032 lithium button cell. In normal use, it will provide 1 to 2 years of operation. To replace the battery, remove the access cover by pressing firmly on the label area and sliding it off. Once the unit is open, remove the battery by sliding it from beneath the holder. There may be the risk of explosion if the battery is replaced by the wrong type. Replace it with the same type of battery while observing the polarity shown in the adjacent figure.



Figure 4: Battery Access

ASSEMBLY DIAGRAM

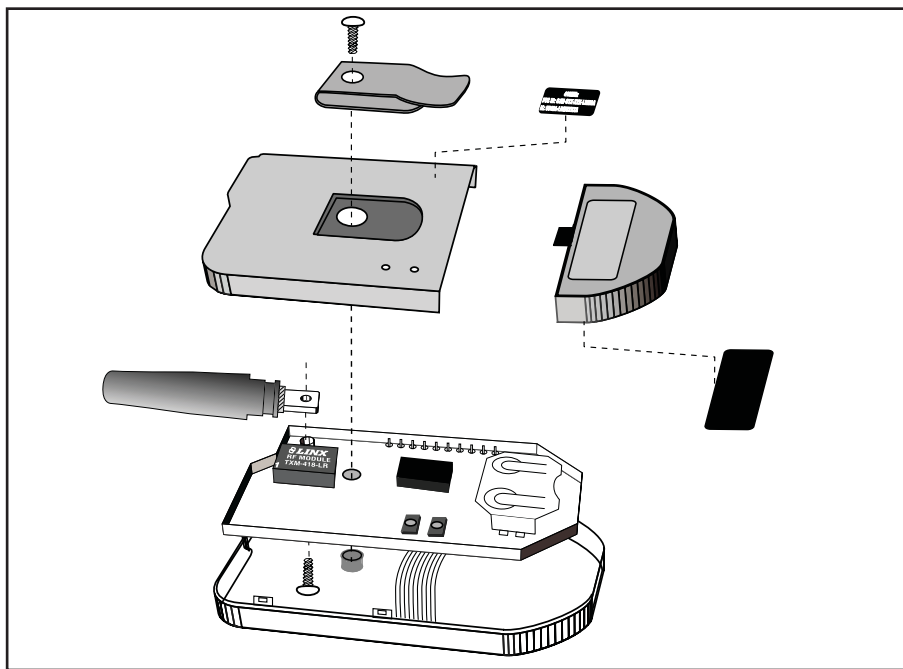

Figure 5: OTX-***-HH-LR8-MS Assembly

COMPLIANCE REQUIREMENTS

The OTX-***-HH-LR8-MS has been pre-certified by Linx Technologies for FCC Part 15 and Industry Canada RSP-100 compliance. The 433.92MHz version has also been tested for CE compliance for use in the European Union. The 315MHz and 418MHz versions are not legal for use in Europe.

LABELING / INSTRUCTION REQUIREMENTS

The OTX-***-HH-LR8-MS Long-Range Handheld Transmitter has already been labeled in accordance with FCC, Industry Canada, and CE regulations in effect as of the date of this document. No further labeling of the unit is needed; however, it is necessary to include the following statement in the end product's instruction manual or insert card for FCC compliance. Industry Canada only requires the shaded portion. The EU does not require a statement.

INSTRUCTION TO THE USER

This device complies with Part 15 of the FCC Rules.

Operation of this device is subject to the following two conditions:

- (1) This device may not cause harmful interference, and
- (2) this device must accept any interference received, including interference that may cause undesired operation.

This equipment has been tested and found to comply with the limits for a Class B digital device, pursuant to Part 15 of the FCC Rules. These limits are designed to provide reasonable protection against harmful interference in a residential installation. This equipment generates, uses and can radiate radio frequency energy and, if not installed and used in accordance with the instructions, may cause harmful interference to radio communications. However, there is no guarantee that interference will not occur in a particular installation. If this equipment does cause harmful interference to radio or television reception, which can be determined by turning the equipment off and on, the user is encouraged to try to correct the interference by one or more of the following measures:

Reorient or relocate the receiving antenna.

Increase the separation between the equipment and receiver.

Connect the equipment into an outlet on a circuit different from that to which the receiver is connected.

Consult the dealer or an experienced radio/TV technician for help.

This equipment has been certified to comply with the limits for a Class B computing device, pursuant to FCC Rules. In order to maintain compliance with FCC regulations, shielded cables must be used with this equipment. Operation with non-approved equipment or unshielded cables is likely to result in interference to radio and TV reception. The user is cautioned that changes and modifications made to the equipment without the approval of manufacturer could void the user's authority to operate this equipment.

Place the above statement in the instruction manual or insert card.

TYPICAL APPLICATIONS

The signal sent by the MS Long-Range Transmitter can be received by an LR Series receiver module or the LT Series transceiver module. The outstanding sensitivity of the LR Series receiver offers the best range when used with a Linx OEM transmitter. The receiver module is then connected directly to an MS Series decoder, which will decode the transmitted signal.

When a button is pressed on the transmitter, a corresponding line on the decoder will go high. This can then be connected to external circuitry to perform whatever function is required by the application.

The decoder must learn the transmitter's address before they can work together. This is done by taking the LEARN line on the decoder high, typically with a pushbutton switch. The MODE_IND line will start switching (if a LED is attached, this will cause it to flash) indicating that the decoder is in Learn Mode. Press any of the buttons on the transmitter to initiate a transmission. Take the LEARN line high again to exit Learn Mode and the system will be ready for use. The figure below shows a schematic for a typical application.

The MS Long-Range Transmitter is set to 9,600bps, so SEL_BAUD0 should be tied high and SEL_BAUD1 tied low.

The decoder has several unique features, such as Latch Mode, Receiver Control, and TX_ID.

If the LATCH line is tied to V_{CC}, the outputs will go high on the first transmission, then low on the second. Figure 6 shows it tied low, so the outputs will be momentary (high for as long as a signal is received that instructs the decoder to make them high).

The RX_CNTL line can be connected to the PDN line of the receiver and the decoder will activate the receiver with a 10% duty cycle. This greatly reduces the average current consumption of the system. The adjacent figure shows it tied to ground, but to use this feature, connect the RX_CNTL line of the decoder directly to the receiver's PDN line.

The TX_ID line will output a number associated with the originating transmitter / encoder. Application Note AN-00156 shows how to use this feature.

Data guides for the receivers, the MS encoder, and the MS decoder can be found on the Linx Technologies website at www.linxtechnologies.com.

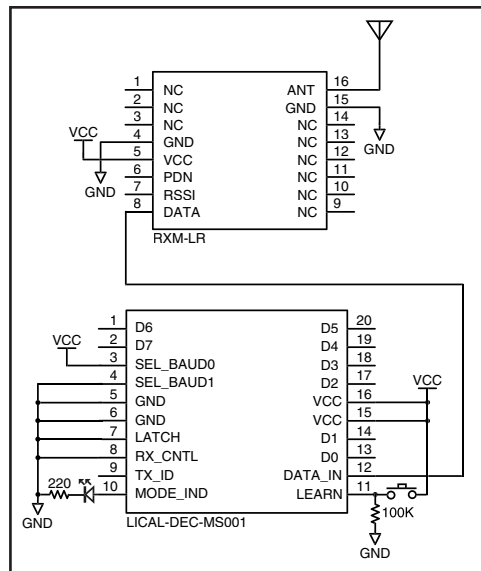
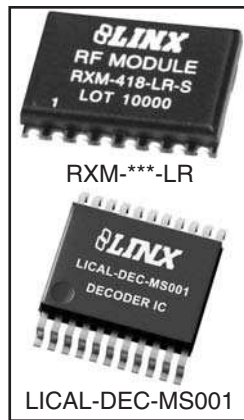

Figure 6: LR Receiver and MS Decoder Schematic

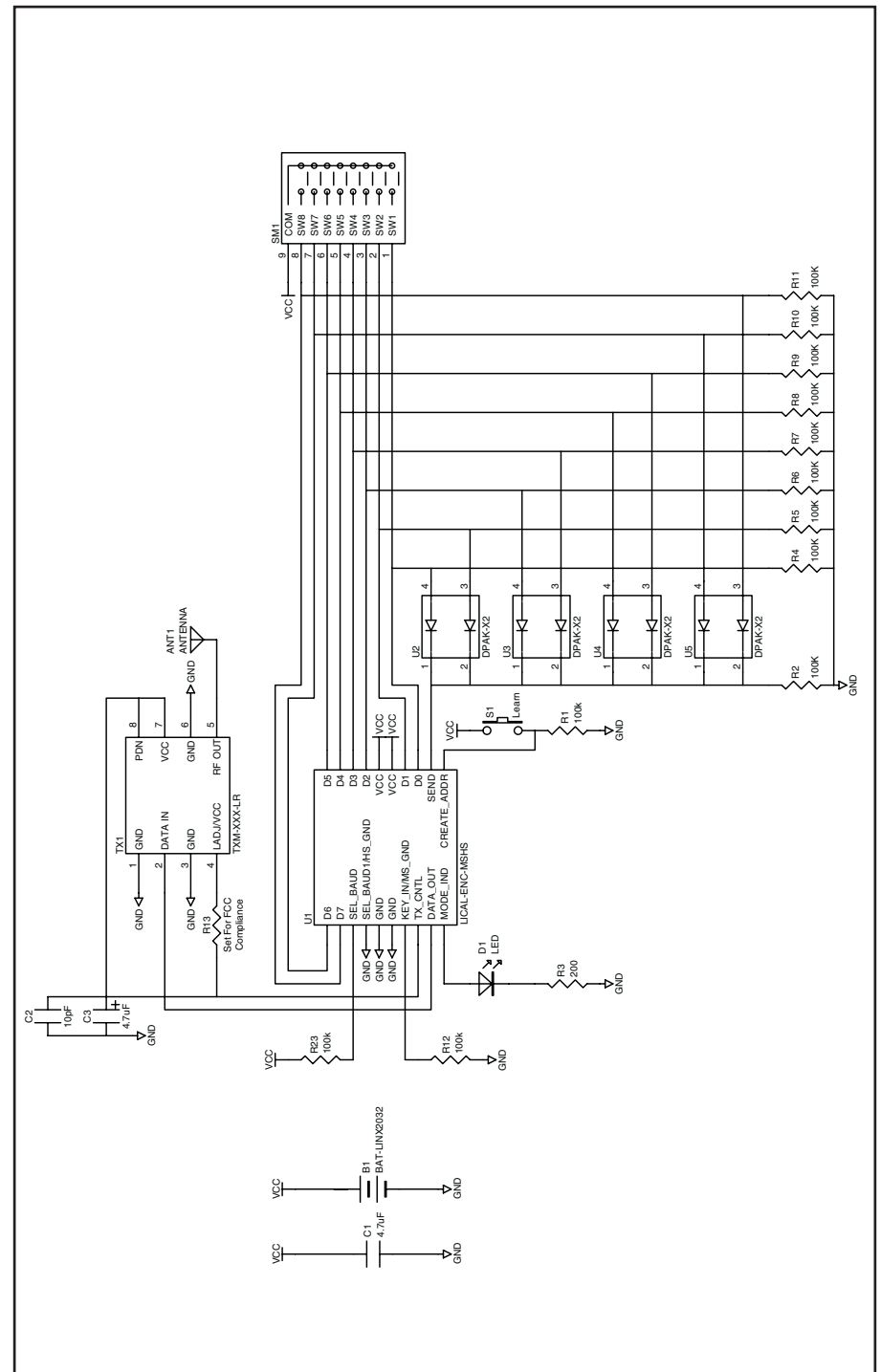

Figure 7: OTX-***-HH-LR8-MS Schematic



U.S. CORPORATE HEADQUARTERS

LINX TECHNOLOGIES, INC.

**159 ORT LANE
MERLIN, OR 97532**

PHONE: (541) 471-6256

FAX: (541) 471-6251

www.linxtechnologies.com

Disclaimer

Linx Technologies is continually striving to improve the quality and function of its products. For this reason, we reserve the right to make changes to our products without notice. The information contained in this Overview Guide is believed to be accurate as of the time of publication. Specifications are based on representative lot samples. Values may vary from lot-to-lot and are not guaranteed. "Typical" parameters can and do vary over lots and application. Linx Technologies makes no guarantee, warranty, or representation regarding the suitability of any product for use in any specific application. It is the customer's responsibility to verify the suitability of the part for the intended application. NO LINX PRODUCT IS INTENDED FOR USE IN ANY APPLICATION WHERE THE SAFETY OF LIFE OR PROPERTY IS AT RISK.

Linx Technologies DISCLAIMS ALL WARRANTIES OF MERCHANTABILITY AND FITNESS FOR A PARTICULAR PURPOSE. IN NO EVENT SHALL LINX TECHNOLOGIES BE LIABLE FOR ANY OF CUSTOMER'S INCIDENTAL OR CONSEQUENTIAL DAMAGES ARISING IN ANY WAY FROM ANY DEFECTIVE OR NON-CONFORMING PRODUCTS OR FOR ANY OTHER BREACH OF CONTRACT BY LINX TECHNOLOGIES. The limitations on Linx Technologies' liability are applicable to any and all claims or theories of recovery asserted by Customer, including, without limitation, breach of contract, breach of warranty, strict liability, or negligence. Customer assumes all liability (including, without limitation, liability for injury to person or property, economic loss, or business interruption) for all claims, including claims from third parties, arising from the use of the Products. The Customer will indemnify, defend, protect, and hold harmless Linx Technologies and its officers, employees, subsidiaries, affiliates, distributors, and representatives from and against all claims, damages, actions, suits, proceedings, demands, assessments, adjustments, costs, and expenses incurred by Linx Technologies as a result of or arising from any Products sold by Linx Technologies to Customer. Under no conditions will Linx Technologies be responsible for losses arising from the use or failure of the device in any application, other than the repair, replacement, or refund limited to the original product purchase price. Devices described in this publication may contain proprietary, patented, or copyrighted techniques, components, or materials. Under no circumstances shall any user be conveyed any license or right to the use or ownership of such items.