

### Product Dimensions

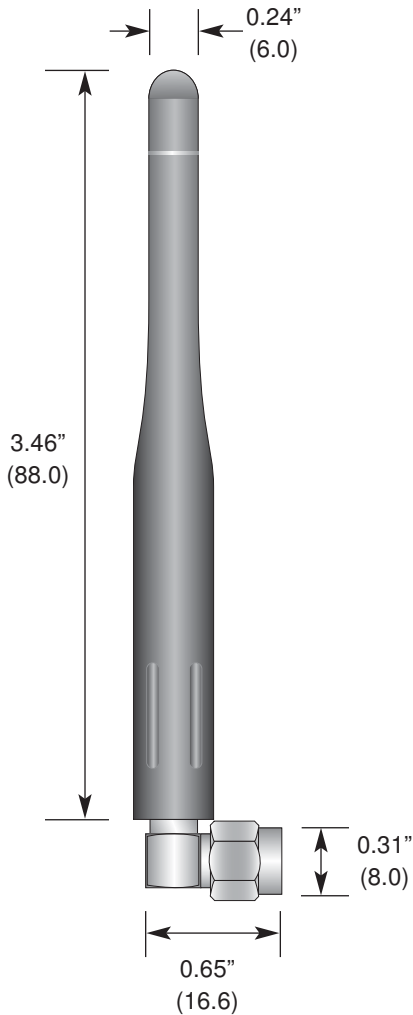

### Description



The RCL Series is useful in products where additional height above the product's case is needed or a slightly wider operational bandwidth is desired. The 916MHz version has a 1/4-wave element. The antennas attach via a Part 15 compliant RP-SMA connector.

### Features

- Right-angle mount
- Reduced-height whip
- Excellent performance
- Omni-directional pattern
- Fully weatherized
- Rugged & damage-resistant
- Part 15 compliant RP-SMA connector

### Electrical Specifications

- Center Freq. 916MHz
- Bandwidth 150MHz
- Wavelength 1/4-wave
- VSWR <1.7 typ. at center
- Impedance 50 ohms
- Connector RP-SMA

Electrical specifications and plots measured on 4.00" x 4.00" reference ground plane

### Ordering Information

- ANT-916-CW-RCL

### VSWR Graph

