

Product Dimensions

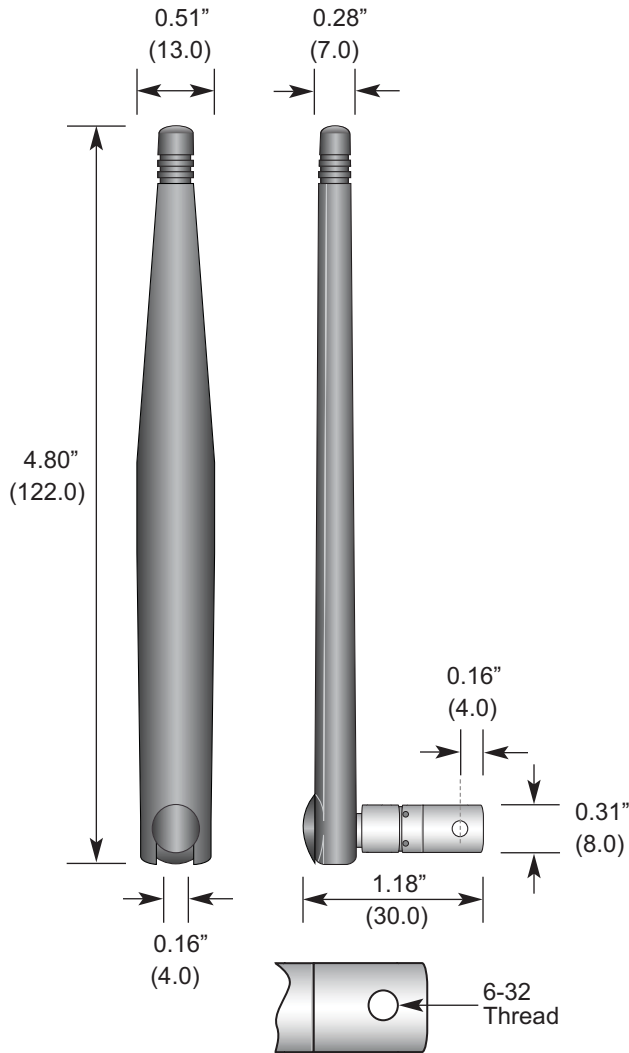

Description



PMC Series 1/4-wave antennas combine a blade-type element with a rugged package that is resistant to damage and abuse. The antennas feature a heavy-duty mounting base and the element can be rotated 360°. The PMC mounts to a PCB via a single screw and meets Part 15 requirements.

Features

- Low cost
- Heavy-duty blade-type element
- Rotates 360 degrees
- Omni-directional pattern
- Weather resistant
- Flexible main shaft
- Screw-mount

Electrical Specifications

- Freq. Bands Band 1 868MHz
Band 2 916MHz
- Bandwidth 200MHz
- Wavelength 1/4-wave
- VSWR <2 typ. at center
- Impedance 50 ohms
- Connection Screw-mount

Electrical specifications and plots measured on 4.00" x 4.00" reference ground plane

Ordering Information

- ANT-868/916-PMC

VSWR Graph

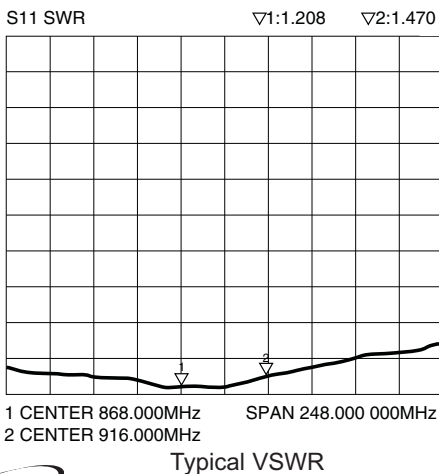

Polar Plot & Gain Information

Monopole antenna gain and radiation patterns are dependant on the ground plane and layout of the end product. Since antenna manufacturers do not measure on standardized ground references, comparison of published specifications is an unreliable indication of actual antenna performance in an end product. Optimum full-wave ground planes are impractical for the majority of products on which these antennas are used (the ground plane for 916MHz would be 26.5" in diameter, 418MHz would be 56.5" in diameter). For this reason, Antenna Factor tests and tunes antennas on reduced-size, compromised ground planes. To avoid mis-comparison or inappropriate application, gain and polar plots do not appear on this data sheet, but are available upon request for most products.

