

ANT-2.4-OC-LG-xxx

Data Sheet

Product Description

The OC Series $\frac{1}{2}$ -wave dipole antennas provide higher gain than a standard whip antenna for increased range and reliability of wireless links. Using loaded coil technology, the OC Series antennas minimize the length that would typically be required to achieve omnidirectional gain. The articulating base allows the antenna to tilt 90 degrees and rotate 360 degrees. The antenna's internal counterpoise eliminates external ground plane dependence and maximizes performance. OC Series antennas attach via a standard SMA or Part 15 compliant RP-SMA connector.

Features

- Low cost
- Compact size
- Tilts and rotates
- Internal counterpoise
- Omnidirectional pattern
- Increased gain versus standard whip antennas
- Standard SMA or Part 15 compliant RP-SMA connector

Electrical Specifications

Center Freq.:	2.45GHz
Rec. Freq. Range:	2.39–2.55GHz
Wavelength:	$\frac{1}{2}$ -wave
VSWR:	≤ 2.0 typ. at center
Peak Gain:	4dBi
Impedance:	50-ohms
Connector:	RP-SMA or SMA
Oper. Temp. Range:	-20°C to $+85^{\circ}\text{C}$

Electrical specifications and plots measured on 10.16 cm x 10.16 cm (4.00" x 4.00") reference ground plane

Ordering Information

ANT-2.4-OC-LG-RPS (with RP-SMA connector)
ANT-2.4-OC-LG-SMA (with SMA connector)

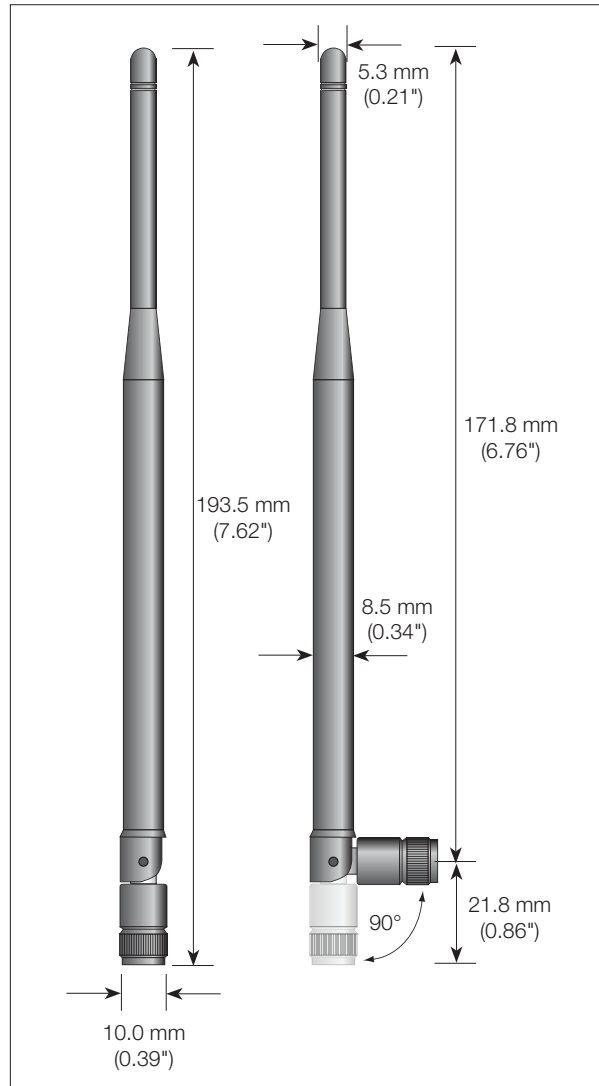

VSWR Graph

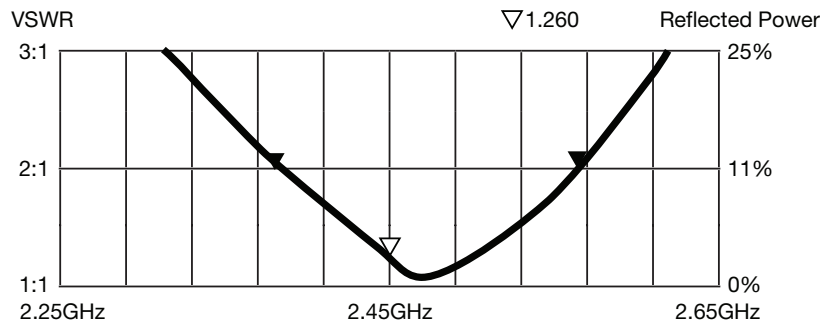

What is VSWR?

The Voltage Standing Wave Ratio (VSWR) is a measurement of how well an antenna is matched to a source impedance, typically 50-ohms. It is calculated by measuring the voltage wave that is headed toward the load versus the voltage wave that is reflected back from the load. A perfect match will have a VSWR of 1:1. The higher the first number, the worse the match, and the more inefficient the system. Since a perfect match cannot ever be obtained, some benchmark for performance needs to be set. In the case of antenna VSWR, this is usually 2:1. At this point, 88.9% of the energy sent to the antenna by the transmitter is radiated into free space and 11.1% is either reflected back into the source or lost as heat on the structure of the antenna. In the other direction, 88.9% of the energy recovered by the antenna is transferred into the receiver. As a side note, since the “:1” is always implied, many data sheets will remove it and just display the first number.

How to Read a VSWR Graph

VSWR is usually displayed graphically versus frequency. The lowest point on the graph is the antenna’s operational center frequency. In most cases, this will be different than the designed center frequency due to fabrication tolerances. The VSWR at that point denotes how close to 50-ohms the antenna gets. Linx specifies the recommended bandwidth as the range where the typical antenna VSWR is less than 2:1.