

200 Transmitter

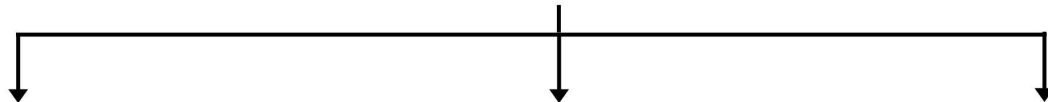

210 Receiver



215 Relay Output



216 Relay Output



230 Relay Output

- Simple to Use Remote Control
- 8 Channels per Transmitter
- 16 Channels per Receiver
- Upto 48 Transmitters per system
- Auto Transmit Mode
- Secure RF Protocol
- Automatic 'Watchdog' Transmission
- Range:
 - Upto 200 metres at 433MHz
 - Upto 1,000 metres at 433MHz Narrow Band.
 - Upto 6,000 metres at 458MHz
- Requires no radio license
- Relay Outputs upto 30A @ 230Vac
- All Modules supplied with Antenna

Remote Telemetry Systems are well suited to industrial switching applications where telemetry signals need to be sent remotely from one location to another.

This system allows multiple transmitters to a single receiver or a single transmitter to multiple receivers.

Each Transmitter module accepts up to 8 pairs of 'Volt Free' contacts as inputs via screw terminals. Each Receiver has 16 outputs arranged as 4 x 4 easy plug in connectors to interface to any combination of output modules.

Any of the output modules connect directly to the receiver (cable supplied) to provide transistor switching or relay outputs.

Transmitters

- 8 Input Channels
- Volt Free contact Inputs via Screw Terminals
- 12 / 24Vdc Supply
- Low Power Battery Version



Part Number	Description	Range** (Metres)	Freq (MHz)	Compatible Decoders
200-433FR	FM Transmitter	200	433.92	210-433F
200-525NR	FM Narrow Band Transmitter	1,000	434.525	210-525N
200-458FR	FM High Power Transmitter	6,000	458.850	210-458F

Receivers

- 16 Output Channels
- Volt Free contact Inputs via Screw Terminals
- 12 / 24Vdc Supply
- Low Power Battery Version



Part Number	Description	Range** (Metres)	Freq (MHz)	Compatible Transmitter
210-433FR	FM Receiver	200	433.92	200-433F
210-525NR	FM Narrow Band Receiver	1,000	434.525	200-525N
210-458FR	FM High Power Receiver	6,000	458.850	200-458F

Output Modules

- Connect Directly to 210 Rx (Cable Supplied)
- no power connections required

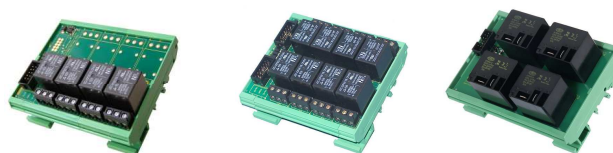

Part Number	Description	No of Outputs	Max Switching (per output)
215	Relay Module	8	5A @230Vac
216	Relay Module	4	5A @230Vac
230	Relays Module	4	30A @230Vac



Enclosure / Power Supply

- IP56 Insulation Class 2
- DIN Rails mounted on Steel Plate
- 12Vdc 1A PSU incorporated accepts 110-240Vac (5A Fused)

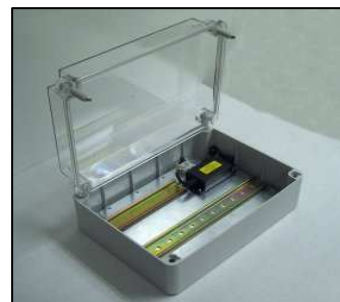

Dimensions

External	315 x 235 x 130mm
Internal	300 x 220 x 120mm
DIN Rail length 1	285mm
DIN Rail length 2	180mm

Part No	Description
ENC-DA3	DIN Rail Enclosure Assembly, Two Mounting Rails, 12Vdc PSU Fitted
PSU12V1AIN-IP	Power Supply 110-240Vac input, 12Vdc 1A Output

Custom systems

We regularly supply pre-wired / bespoke systems, please contact our sales dept for further assistance

**R. F. Solutions Ltd.,
Unit 21, Cliffe Industrial Estate, South Street, Lewes,
E Sussex, BN8 6JL. England**

Tel +44 (0)1273 898 000 Fax +44 (0)1273 480 661

Email sales@rfsolutions.co.uk <http://www.rfsolutions.co.uk>

RF Solutions is a member of the Low Power Radio Association

Information contained in this document is believed to be accurate, however no representation or warranty is given and R.F. Solutions Ltd. assumes no liability with respect to the accuracy of such information. Use of R.F.Solutions products as critical components in life support systems is not authorised except with express written approval from R.F.Solutions Ltd.



1 Configuring a Remote Telemetry System (200Tx -> 210Rx)

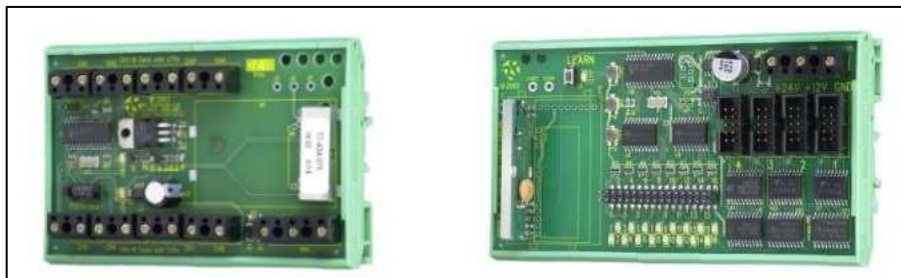

There are three Steps:

1. Pre-Configure the 200 series transmitter
2. Pre-Configure the 210Rx to operate with a 200 series transmitter
3. Marry a 200Tx to a 210Rx

1.1 Pre-Configure a 200 Transmitter Encoder

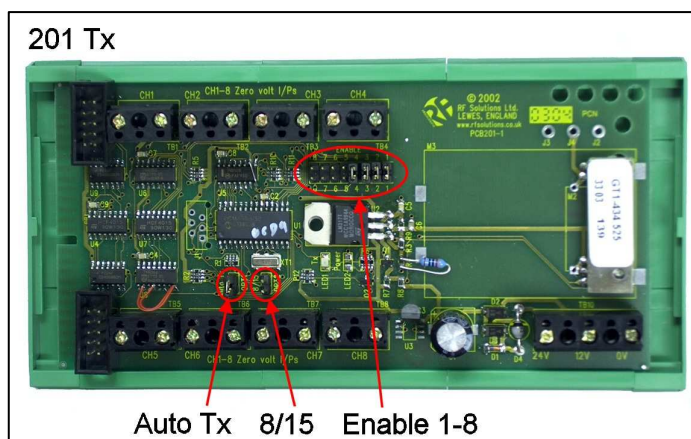
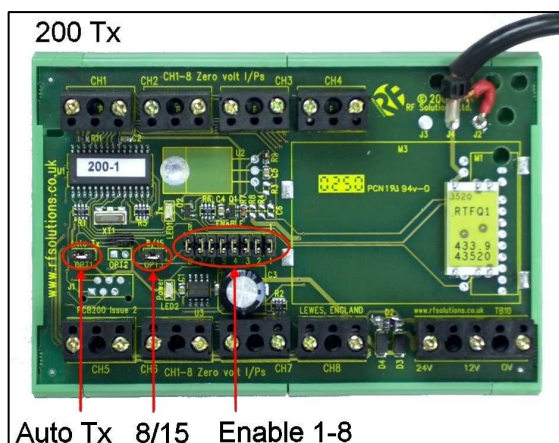

1. Mapping the 200 Transmitter Inputs to the 210 Receiver Outputs

The Remote telemetry system automatically maps the 8 transmitter input channels to 8 receiver output channels. The '8/15' option link on the transmitter allows selection of channels 1-8 or 9-15 on the receiver.

200 Tx Option Link	210 Rx output Channels
Open	1 – 8
Connected	9 – 15

2. Enable Option Links (ENABLE 1-8)

The 200 Transmitters have eight 'Enable' Option links which must be fitted in order for the corresponding input to be valid (otherwise the 210Tx will ignore it). This enables applications where many transmitters are used with a single 210Rx (many to one relationship)

3. Auto Transmit with Watchdog Mode 'Auto Tx'

When the 'Auto Tx' link is made, the 200 Tx automatically transmits its data once within every 5 second period, in addition, channel 16 is allocated as a 'system watchdog'. As long as the 210Rx continues to receive this signal then output '16' is held ON. If for any reason (fault or RF interference) the signal is not received for approx 20secs then output '16' will drop out.

1.2 Pre-Configure a 210Rx to operate with a 200 Tx series transmitter

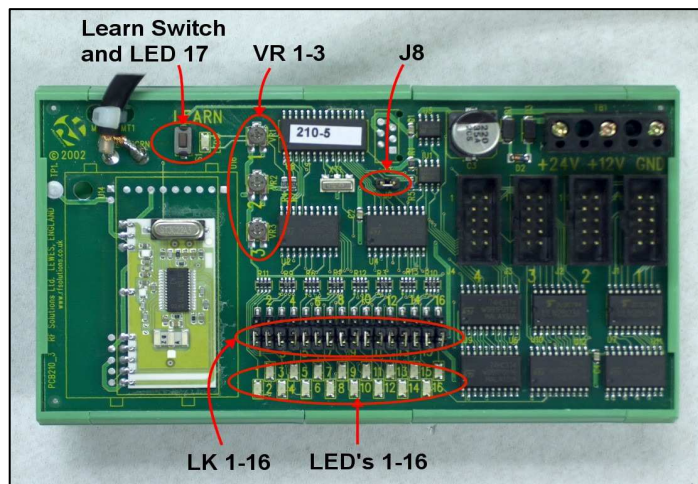

1. Ensure option link J8 is open.
2. Apply power to the 210Rx, All output LEDs flash alternately. This is factory reset default state.
3. Apply power to any 200 Tx and briefly operate any input by shorting any of the input terminals on the transmitter (ensure Enable link is fitted!), to force a transmit.
4. The 210Rx. LED2 flashes 5 times to indicate that the 210Rx is now configured for use with 200 Tx.
5. Each time power is applied the 210Rx, LED2 flashes 5 times to show it is configured to operate with 200Tx transmitters.
6. Configuration is now complete and 200/201 transmitter unit(s) can be learned to the 210Rx receiver.

Note: Option links LK 1-16 have no affect on the operation of the remote telemetry system.

1.3 Marry a 200Tx to a 210Rx

1. On the 200 Tx, remove the Link header 'OPT1' (auto Tx). (prevents automatic transmission during the learn process).
2. On the 210Rx Ensure option link J8 is open.
3. Apply power to the 210Rx, note that LED2 flashes 5 times to show it is configured for use with 200Tx transmitters.
4. Briefly press the 210Rx Learn Switch: Note that the 210Rx Learn LED (LED 17) will flash.
5. Wait until the 210Rx Learn LED has stopped flashing but is still illuminated.
6. Apply power to any 200 Tx and briefly operate any input by shorting any of the input terminals on the Transmitter (ensure Enable link is fitted!), to force a transmit.
7. Note that the 210Rx learn LED will turn off.
8. The learn cycle is now complete and the transmitter/encoder will operate the systems.

1.4 Erasing the 210Rx Receiver Outputs (Return to Factory Default State)

1. To completely erase the 210Rx decoder's memory, press and hold the 210Rx learn switch.
2. The learn LED will illuminate
3. Hold the learn switch until the learn LED extinguishes (approx 10 seconds).
4. Release the learn button and all the output LED's will now flash alternately to indicate that all encoder data has been erased and the 210Rx has returned to factory default state.

Note: It is not possible erase individual transmitters.



1.5 Connecting output Modules to the 210 Receiver

A range of '200' series output modules are available which can be plugged into the 210 Receiver via the four IDC header boxes on the receiver. The selection of output module will be dependant on the application. Please see DS200S-1 for a summary the available modules.

1.6 Connecting an Antenna

The 210Rx has a 200mm flying lead cable (50ohm) with a panel mount BNC socket provided to mount on an enclosure. This cable may be extended however please note that typically there is a 50% range reduction with every 3metres of coax cable used!

For increasing range performance a +3dB gain antenna is available. This is supplied with wall mounting bracket and 2metres of coax cable, it plugs in directly to the 210Rx BNC connector.

1.7 Range

The antenna choice and position directly controls the system range. Keep it clear of other metal in the system. The best position by far, is protruding from the top of the product. This is often not desirable for practical or ergonomic reasons and thus a compromise may be needed. If an internal antenna must be used then try to keep it away from other metal items, and in particular large ones like transformers, batteries and PCB tracks and earth planes.

Note that the space around the antenna is as important as the antenna itself. All radio systems are dependant on a radio signal being received through airspace.

The range quoted is the optimal in direct line of sight without obstacles and in good atmospheric conditions.

Range is affected by many things, for example local environmental conditions, atmospheric conditions, interference from other radio transmitters. For evaluating the local environment please see our RF Meter (DS006)

In very worse case applications the range quoted may be reduced to 30% of the optimal range stated.

1.8 Signal integrity

In systems where many encoders are in close proximity there may be occasions when, due to signal overlay between encoders, it is difficult or impossible to guarantee system integrity. In such circumstances it is the responsibility of the installer to ensure that the system performance is adequate for the purposes of the installation.

1.9 Information availability

All products are supplied with their relevant datasheets. These are also available for download from the website or on request from RF Solutions Ltd.

**R. F. Solutions Ltd.,
Unit 21, Cliffe Industrial Estate, South Street, Lewes,
E. Sussex, BN8 6JL, England**

Tel +44 (0)1273 898 000

Fax +44 (0)1273 480 661

Email sales@rfsolutions.co.uk

<http://www.rfsolutions.co.uk>

RF Solutions is a member of the Low Power Radio Association

All Trademarks acknowledged and remain the property of the respected owners



Module Technical Specifications

Transmitters

- 8 Input Channels
- Volt Free contact Inputs via Screw Terminals
- 12 / 24Vdc Supply
- Range;
 - 433MHz up to 200 Metres
 - 433MHz NB up to 1,000 Metres
 - 458MHz up to 6,000 Metres
- High Security RF Protocol
- Low Power Battery Version
- Auto Transmit Mode
- Automatic 'Watchdog' Transmission
- Antenna Supplied

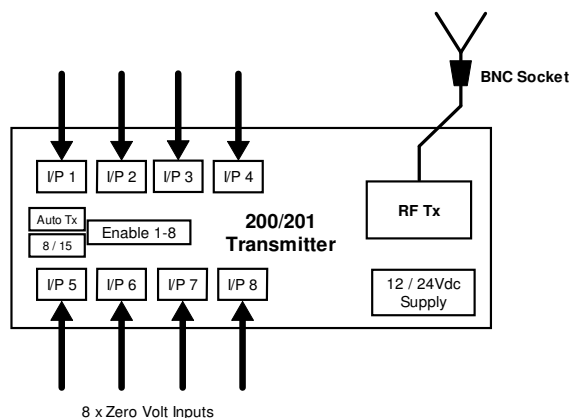
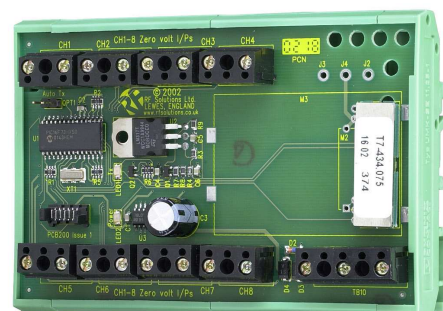

This is a simple to use radio transmitter module which can accept 8 pairs of 'Volt free' contacts inputs. When an input occurs the transmitter will transmit a data packet over the RF link to an associated receiver. (That has been learnt into the transmitter). The transmitter continually monitors the status of its 'inputs'. It transmits a signal on any input change and also can be set to transmit automatically every 15 seconds. Full configuration instructions are given further in this document.

200 Transmitter: Standard transmitter

Part Numbering

Part Number	Description	Range** (Metres)	Freq (MHz)	Compatible Decoders
200-433FR	FM Transmitter	200	433.92	210-433F
200-525NR	FM Narrow Band Transmitter	1,000	434.525	210-525N
200-458FR	FM High Power Transmitter	6,000	458.850	210-458F

** Range stated is optimum, direct line of sight. In worst conditions this can be reduced by upto 50%



Technical Specifications

Dimensions: Within DIN Rail: 200Tx : 112 x 82 mm (PCB: 109 x 72mm)

Storage Temperature; -10 to +155° C

Operating Temperature; -0 to +55° Celsius.

Electrical Characteristics	Min	Typical	Max	Units
Supply Voltage: 12V Supply	10	12	16	V
Supply Voltage: 24V Supply	21	24	30	V
Antenna Output Lead Impedance		50		Ohms
Minimum input activation time to trigger transmission		5		ms
433MHz / 433NBMHz Version				
Supply Current: Quiescent		10		mA
Supply Current: Transmitting Data	150	170	200	mA
458MHZ Version				
Supply Current: Quiescent		10		mA
Supply Current: Transmitting Data	240	250	270	mA

200 Transmitter Current Consumption	Min	Typical	Max	Units
433MHz / 433NBMHz Version				
Supply Current: Quiescent		10		mA
Supply Current: Transmitting Data	150	170	200	mA
458MHZ Version				
Supply Current: Quiescent		10		mA
Supply Current: Transmitting Data	240	250	270	mA

R. F. Solutions Ltd.,
Unit 21, Cliffe Industrial Estate, South Street, Lewes,
E. Sussex, BN8 6JL, England

Tel +44 (0)1273 898 000 Fax +44 (0)1273 480 661

Email sales@rfsolutions.co.uk <http://www.rfsolutions.co.uk>

RF Solutions is a member of the Low Power Radio Association

Information contained in this document is believed to be accurate, however no representation or warranty is given and R.F. Solutions Ltd. assumes no liability with respect to the accuracy of such information.
 Use of R.F.Solutions as critical components in life support systems is not authorised except with express written approval from R.F.Solutions Ltd.



Receivers

This DIN rail module performs the radio reception and decoding for the 200 series modules. It has four output connectors each with four digital outputs and displays the output status on LED's 1-16. Any of the DIN Rail output modules lug into these connectors marked 1-4 (Connecting cable supplied with output module).

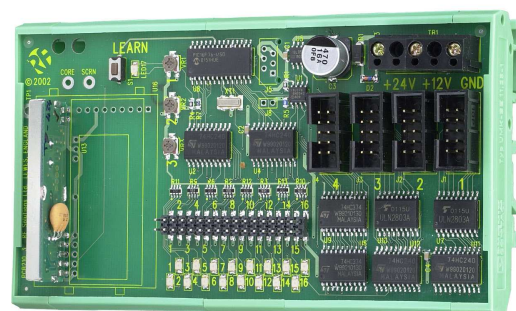

Connector	O/P Channels
1	1 - 4
2	5 - 8
3	9 - 12
4	13 - 16

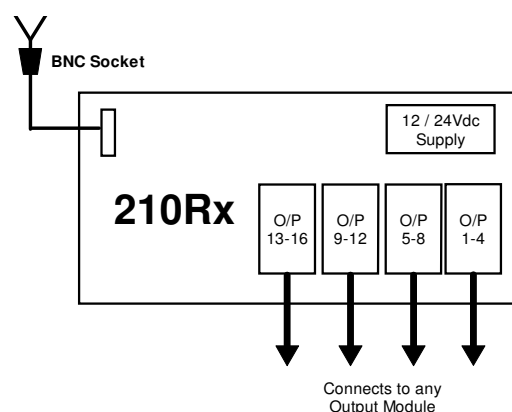

Technical Specifications

Dimensions: Within DIN Rail: 138 x 82 mm (PCB: 133 x 72mm)
Storage Temperature: -10 to +70° Celsius. **Operating Temperature:** 0 to +55° Celsius.

Electrical Characteristics	Min	Typical	Max	Units
Supply Voltage: 12V Supply	10	12	16	V
Supply Voltage: 24V Supply	21	24	30	V
Supply Current : Quiescent		25		mA
Time from Tx Switch depressed to 210Rx output			100	mSecs
Time from Tx Switch release to Decoder output			200	mSecs
Switched output Voltage (I out = 1mA)				
Logic Low	0	0.2	0.8	V
Logic High	3.5	3.8	5	V

Part Numbering

Part No	Description
210-433FR	Receiver Decoder 16 Channels DIN Rail Mounting, FM @ 433.92MHz
210-525NR	Receiver Decoder 16 Channels DIN Rail Mounting, FM Narrow Band @ 434.525MHz
210-458FR	Receiver Decoder 16 Channels DIN Rail Mounting, FM High Power @ 458.850MHz

Output Modules

215 & 216 Relay Output Module

- 215 = 8 relays
- 216 = 4 Relays
- Relay outputs rated at 230Vac ,12A peak and 6A continuous current rating.
- 'normally open' and 'normally closed'

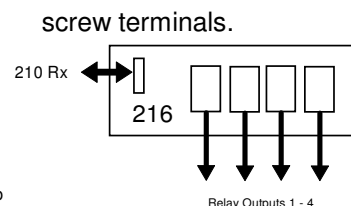
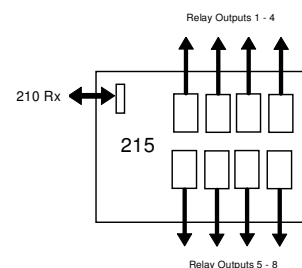

Dimensions: Within DIN Rail: 135 x 82 mm (PCB: 132 x 72mm)
 Storage Temperature: -10 to +70° Celsius. Operating Temperature: 0 to +55° Celsius.

Electrical Characteristics	Min	Typical	Max	Units
Supply Voltage	From 210Rx module			
Relay* output Rating (type KB12) at 230Vac		6	12	A

*The relay contacts in this unit are for functional use only and must not be used for isolation purposes

230 Relay Output Module

- 4 relay (type K7SFA12) outputs rated for up to 30A at 230Vac.
- Each relay provides 'input' and 'normally open' Spade Terminals.

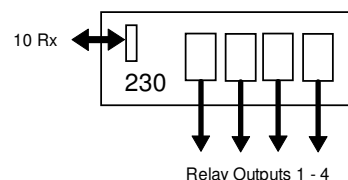

Dimensions: Within DIN Rail: 115 x 82 mm (PCB: 109 x 72mm)
 Storage Temperature: -10 to +70° Celsius. Operating Temperature: 0 to +55° Celsius.

Electrical Characteristics	Min	Typical	Max	Units
Supply Voltage	From 210Rx module			
Relay output Rating @ 230Vac*			30	A
@ 12Vdc			20	A

*The relay contacts in this unit are for functional use only and must not be used for isolation purposes

R. F. Solutions Ltd.,
Unit 21, Cliffe Industrial Estate, South Street, Lewes,
E Sussex, BN8 6JL. England

Tel +44 (0)1273 898 000 Fax +44 (0)1273 480 661

Email sales@rfsolutions.co.uk http://www.rfsolutions.co.uk

RF Solutions is a member of the Low Power Radio Association

Information contained in this document is believed to be accurate, however no representation or warranty is given and R.F. Solutions Ltd. assumes no liability with respect to the accuracy of such information. Use of R.F.Solutions products as critical components in life support systems is not authorised except with express written approval from R.F.Solutions Ltd.