

Radio MODEM Module

Features

- Intelligent RF Modem Module
- Serial Data Interface with Handshake
- Host Data Rates up to 38,400 Baud
- RF Data Rates to 115Kbps
- Range up to 2Km
- Minimal external components
- Direct Led Drive Shows Data Flow
- 8 User Selectable Channels
- Secure Data Protocol
- Ultra Low Power 2.2 - 3.6V Operation
- CE Compliant for Licence Free Use
- 868MHz or 915MHz Versions
- 100mW Transmit Power (+20dBm)
- Receiver Sensitivity -121dBm

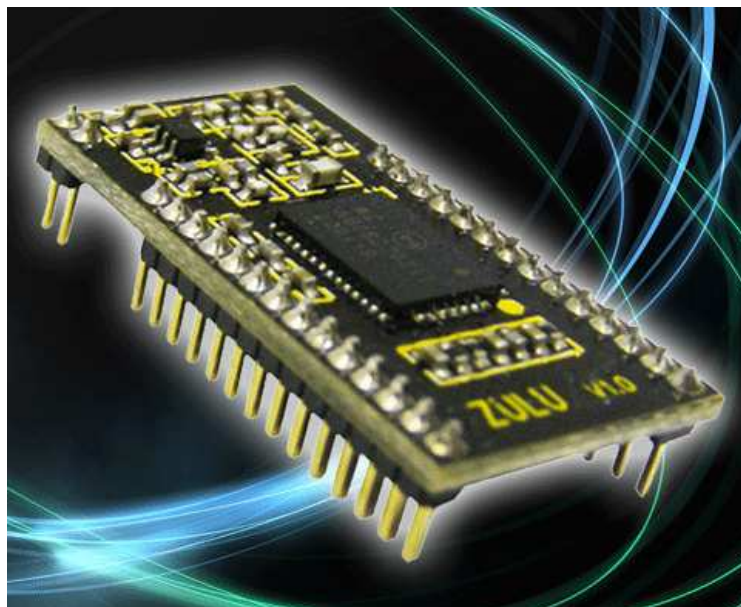

Applications

- Remote Networking
- USB/RS232 Cable Replacement
- Remote Data Log
- Meter Reading

The ZULU Modem module is a highly integrated RF Modem and intelligent controller with simple interface to achieve a wireless serial data link for data (up to 38K4bps) over 2KM range. Range may be further extended with suitable antenna.

The user interface is standard RS232 style control operating at low voltage. All RF operation is automatically controlled (with error checking etc) so the Zulu can be treated as a simple Communications device. Possible applications include one-to-one and multi-node wireless links in applications including car and building security, EPOS, inventory tracking, remote industrial process monitoring and computer networking. Because of their small size and low power requirements this module is ideal for use in portable, battery-powered applications such as hand-held termi-

Part No	Description
ZULU-M868	Radio Modem Module DIP Package 868MHz
ZULU-M868-SO	Radio Modem Module SMT Package 868MHz
ZULU-M915	Radio Modem Module DIP Package 915MHz
ZULU-M915-SO	Radio Modem Module SMT Package 915MHz

Pinout

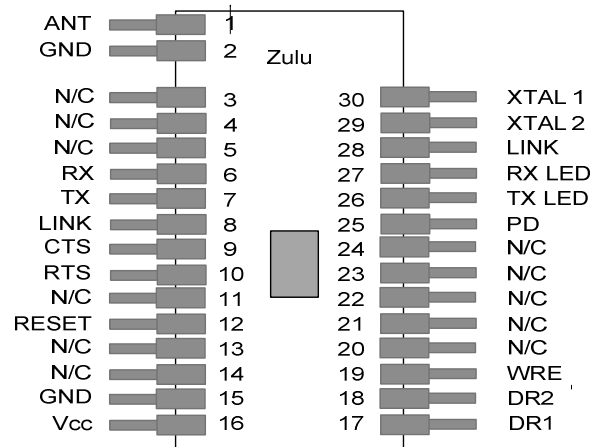

Pin Description

Pin No	Name	Direction	Description
1	ANT	In	Antenna Input / Output 50ohm Impedance
2, 15	GND	In	Connect to Ground
3-5, 11, 13-14, 20-24	N/C	N/A	Unused Leave Disconnected.
6	RX	In	(Low Level RS232) Data in
7	TX	Out	Low Level RS232 Data Out
8	LINK	In	Connect to LINK on Pin 28
9	CTS	Out	Low Level RS232 CTS
10	RTS	In	Low Level RS232 RTS
12	RESET	In	Device Reset Input (Tie High via 10K Resistor)
16	Vcc	In	+2.2 - 3.6v
17-18	DR1-DR2	In	Host Data Rate selection.
19	WRE	In	When High configuration data is held in EEPROM. When Low configuration data is held in volatile memory and lost on power cycle.
25	PD	In	Power down mode. Take low to enter Sleep mode
26	TX LED	Out	RF TX LED indicator
27	RX LED	Out	RF RX LED indicator
28	LINK	Out	Connect to LINK on Pin 8
29-30	XTAL1-2	In	Connect 30MHz XTAL here to drive RF Circuit

Pin Descriptions:

RX, TX

This is the Data Input / Output. Data is transmitted and received at the low voltage level (dependant on Vcc being used). Compatible with LCTTL / LVCMOS

Serial Data Format

Baud Rate: Defined by DR1 and DR2 Pins

Data Bits: 8

Parity: None

Stop Bits: 1

Flow Control: Hardware CTS / RTS

CTS, RTS

Clear to Send and Request to Send are standard data flow control used in RS232 systems, these are standard but operate at the Zulu Vcc low level voltage.

If no handshaking required RTS may be pulled low, however beware of data overrun errors of transmitting streams of data longer than the data buffer!

RESET

Connection to GND Resets the Zulu Module. Zulu Modem starts up when this input is taken from GND to Vcc. Normal connect to a 10Kohm operation: Vcc through Resistor

DR1	DR2	Host Baud Rate
Vcc / Unconnected	Vcc / Unconnected	4,800
Vcc / Unconnected	GND	9,600
GND	Vcc / Unconnected	19,200
GND	GND	38,400

Vcc:

Supply Voltage (2.2—3.6V)

DR1 - DR2

These inputs define the host interface Baud Rate. They are read when RESET pin goes high. Tip: It is good practice to operate the host interface at half the speed of the RF data rate (set by Register R5)

PD

This input enables 'Sleep' Mode. For normal operation connect to Vcc. No RF packets will be received by the module when it is in sleep mode.

WRE

Controls where the User configuration parameters are saved in internal EEPROM (Non-Volatile) or RAM (Volatile) Un-used. This may be ignored unless the application requires specific address timing on power up.

Tx / Rx LED

Direct LED Drive which operates whenever there is RF activity.

Operation Overview

The ZULU MODEM Module provides a simple Modem interface to the host controller. It handles all RF data communications automatically and without any requirement from the user (RF packetising , Preamble, Encoding, CRC Check etc).

With this powerful high-speed Radio link. The following networks can be realised;

One-to-One operation; for point to point data communication

One-to-Many; A network consisting a master and many slaves (the receivers all have the same address)

Many-to-One; where the transmitters all send to a single receiver address.

Because each ZULU MODEM can contain a unique address, multiple ZULU networks can co-exist in the same area.

Note: This type of operation requires clear timing between transmissions or corruption of packets can occur. It is no a recommended transmission type.

Broadcast operation; where a single master Zulu MODEM addresses many ZULU MODEMS concurrently. (using many ZULU MODEM modules set to the same address),

Operating Modes

Configuration Mode: In Configuration mode the Zulu MODEM can receive a number of commands and the internal registers can be pre-set to control its operation. In this mode the Zulu MODEM is 'Offline' and cannot send or receive RF data.

Normal Operation : ZULU MODEM is 'Online' automatically transmitting and receiving data from its host and across the RF network.

Each ZULU MODEM has its own pre-set address. This is user set during configuration. Any data received is examined and the address header embedded within the data packet is compared with its address. Only data received with matching address will be processed and output to the host, all other data will be discarded.

All ZULU MODEM modules are shipped with a default address of 7E7E7E.

Application Circuit

Connection of the ZULU Modem to an RS232 or USB host terminal device such as a PC serial port may easily be achieved.

Please see schematic is printed later in this datasheet.

Configuration Mode (offline)

Commands can be set using a standard Terminal program or by sending the relevant ASCII characters.

Each Command must be followed by the Carriage Return <CR> or 'Enter'

Note All commands are entered in upper case

Com-mand	Description	Response from Zulu
+++	Enter Configuration Mode Note: these must be sent as a string with no char in front or behind this is to ensure that the +++ is not mistakenly received in mid data.	Zulu responds with Status info
?	retrieve the current register values	Zulu responds with all Register Values
F	set factory defaults; R1=7F7F7F R2=7F7F7F R3 = Ch2 (869.450MHz) R4 = 7 (+20dBm) R5 = 1 (19K2)	'OK'
H	Help	Brief description of commands available
P	Ping Mode This sends a ping request . On receiving, the recipient Zulu Modem will respond with its address and the level of RSSI (Received Signal Strength) The Ping command is continuously repeated every 1 second until any command or character is entered.	The originating Zulu Modem will respond with the Recipient Zulu Modems' response, eg. Received from 7F7F7F (D5) Where 7F7F7F = the recipient Address D5= RSSI RSSI Is a Hex value corresponding to the received signal strength Min = 20hex Max =E0hex
S S	Save Configuration	'SAVED'
Q	exit configuration mode and return to online mode	No response

Register Setting (Configuration Mode)

The internal registers enable various parameters to be controlled.

To set a register type 'R#='x' where # is the register number (1-6) and x is the value to set

For example, to set the channel to channel 3 type : R3=3<CR>

(Where <CR> is carriage return or enter on the keyboard) The modem will then return 'OK' or 'Error' if an incorrect command is entered. Save the changes by typing : S<CR>

The modem will return with 'SAVED'

Register	Value Range	Description	Example
R1	0000 - FFFFFFFF (24 bit address)	Sets the recipient Zulu MODEM Address	R1=0001 (Data sent is addressed to Zulu)
R2	0000 - FFFFFFFF (24 bit address)	Set own Zulu Modem address	R2=F001 (Data sent is from Zulu MODEM with address F001)
R3	CH0 to CH4	Sets the RF Channel See "RF channel Selection"	R3=2 (Transmit on Channel 2)
R4	0 = +1dBm 1 = +2dBm 2 = +5dBm 3 = +8dBm 4 = +11dBm 5 = +14dBm 6 = +17dBm 7 = +20dBm	Set the RF Transmit Power output*	R4=7 (sets Transmit Power to max)*
R5	0 = 9,600 1 = 19,200 2 = 28,800 3 = 56,000	Set the RF baud rate*	R5=3 (sets the RF data rate to 56Kbps)

***Note :**

- Reducing Tx power reduces battery consumption!

RF Channel Selection 868MHz version

The EU standard sets maximum power transmission limits dependent on frequency, bandwidth and application. Please check the relevant standards are being met when implementing your Application. A rough guidance applicable to the ZULU channel numbers is given below

Channel Number	Frequency Centre (MHz)	EU Power Allowance mW / dBm	Notes
0	868.400	25 / 14	Applicable standard - EN300-220
1	868.900	25 / 14	
2	869.450	100 / 20	
3	869.600	100 / 20	
4	869.800	25 / 14	

RF Channel Selection 915MHz version

The 915MHz version uses Spread spectrum frequency hopping and there is no user selectable channels
The channels used are, 915.000, 915.100, 915.200, & 915.300MHz

Mechanical Dimensions

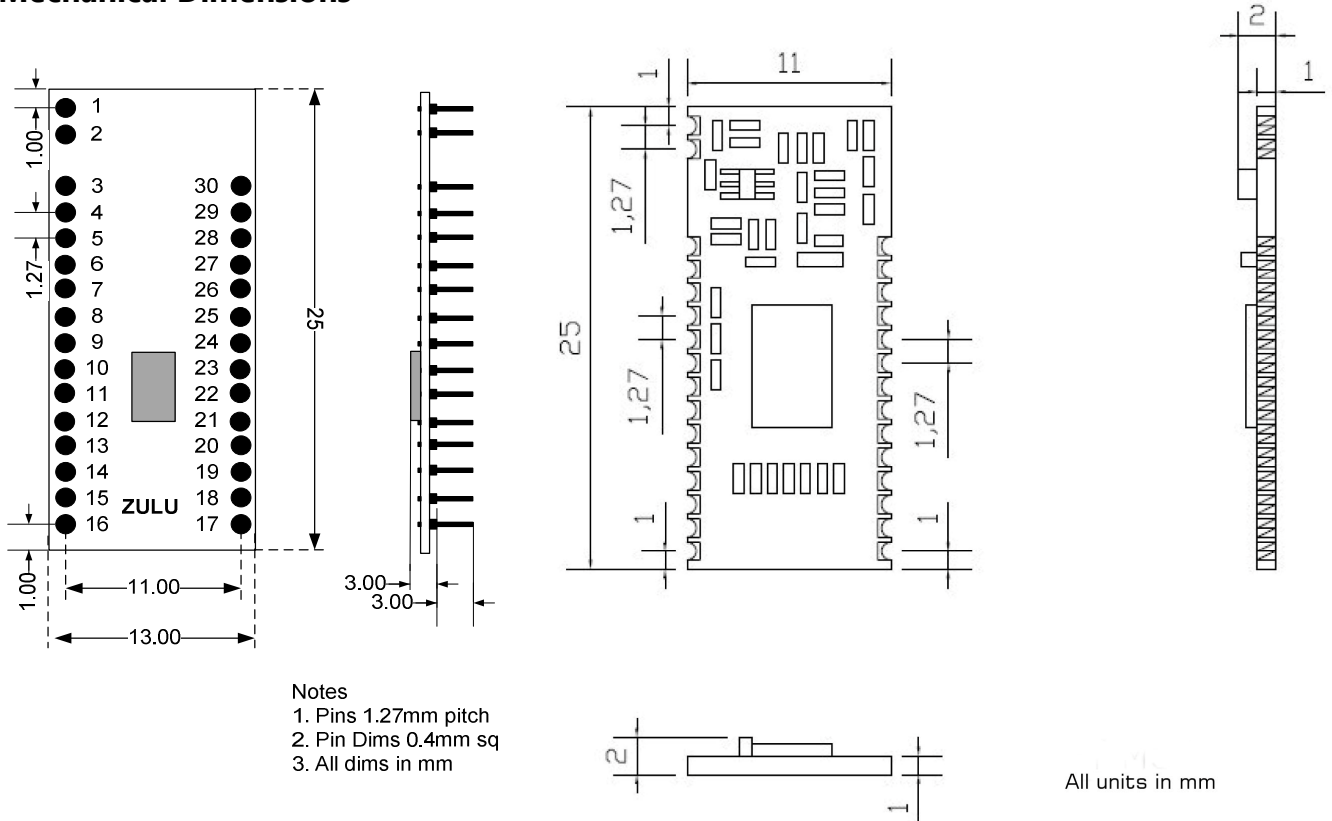

Range

The antenna choice and position affects controls the system range. Keep it clear of any large metal components in the system. The best position by far, is protruding vertically from the top of the product. This is often not desirable for practical reasons and thus a compromise may be needed. Note that the space around the antenna is as important as the antenna itself. All radio systems are dependant on a radio signal being received through airspace.

The range quoted is the optimal in direct line of sight without obstacles and in good atmospheric conditions.

Range is affected by many things, for example local environmental conditions, atmospheric conditions, interference from other radio transmitters. For evaluating the local environment please see our RF Meter (DS006)

In the worst case, range quoted may be drastically reduced.

Recommended Antenna

The BEAD Antenna provides a Miniature PCB mounting solution where performance is required from a small space .

Available as straight or 90 degree mount this antenna is a general purpose omni-directional. It measures 8.5mm long, Dia 7mm.

Please see Datasheet ANT-BEAD-868



Technical Specifications

Absolute Maximums:

Temperature Range: Storage -50 to +125°C.

Weight: SMT version 7grams, DIP Part 13grams

Parameter	Min	Max	Units
Supply Voltage		4.0	V
Voltage on any Input	$V_{cc} > 2.2$	5.8	V
	$V_{cc} < 2.2$	$V_{cc} + 3.6$	V
Max Input power (thro Antenna)		+5	dBm

Parameter	Min	Typical	Max	Units
Supply Voltage	1.8		3.6	V
Operating Temperature	-40		+85	°C
Zulu Tx Supply Current:				
When Transmitting (At Max Power)		85		mA
When sleeping		1		uA
Zulu Rx Supply Current:				
When Receiving		18.5		mA
When sleeping		1		uA

AC Characteristics

Parameter	Min	Typical	Max	Units
Operating Frequency—see freq channel setting	868		870	MHz
Operating Frequency—915MHz Version	915.00		915.30	MHz
Operating Temperature	-40		+85	°C
Band width per channel		100		KHz
Deviation		45		KHz
Zulu Tx MAX Output Power			+20	dBm
Zulu Tx—Rx FSK Raw RF Data Rate	9.6		56	Kbps
Zulu Rx Sensitivity		-121		dBm

Zulu Modem Evaluation Board

The ZULU EVAL Board provides a ready made platform which can be used to demonstrate the capabilities of ZULU Modem Modules providing ready made RS232 and USB Modem Solutions.

Features

- Direct Connection to RS232 / USB
- 9-12Vdc Power in Screw Terminal
- LED Indication Transmit / Receiver
- User Config Jumper Links

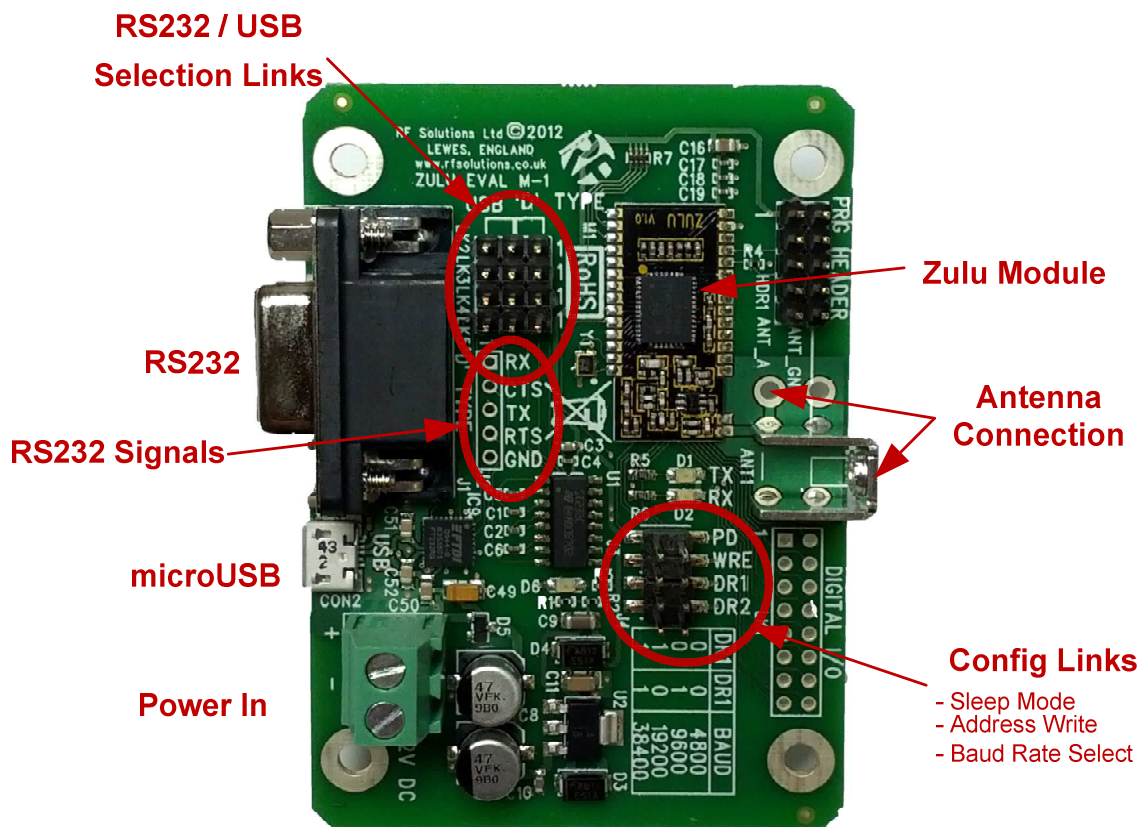

Part No	Description
ZULUEVAL-M868	Zulu Modem Eval Board 868MHz
ZULUEVAL-M915	Zulu Modem Eval Board 915MHz
PSU-12V100MAUK	Plugtop Power Supply 12V 100mA

EVAL Board Configuration

Power Requirements: 9-15Vdc

Weight: 27grams, Dimensions:

Config Links

USB / D Links (LK2,3,4,5)

Link Ref	Name	When Fitted	When Open
PD	Power Down	Modem is Placed in Sleep Mode	Normal Operation
WRE	Write Enable	On each Power up with Zulu Config setting are reset to defaults	On Power up Zulu Config settings remain unchanged
DR1 DR2	Sets Host Baud	DR1 DR2 Open Open Open Fitted Fitted Open Fitted Fitted	Baud Rate: 4800 9600 19200 38400

For USB connect all Links from Centre to 'USB' Side

For RS232 connect all Links from Centre to 'RS232' Side

Antenna Connector

The connector is a 4mm Screw Thread (Part NO: SCRTM4RA)

Power Connection

Power is required for RS232 comms, USB connection provides power automatically—note that USB port cannot supply adequate power for full +20dBm transmission! Additional power is needed for maximum range!

Host Terminal Software

Connection to Host is via the micro-USB Cable or RS232 Cable.

Any Terminal emulation program can interface the Eval board, one we have found to be easy to use and powerful is 'Terminal'

This can be downloaded from : <https://sites.google.com/site/terminalbpp/>

<https://sites.google.com/site/terminalbpp/>

Notes for Optimising Range

In order to obtain the best range

1. Use max RF Transmit power (set Register R4 = 7)
2. use the slowest RF comms Rate (set Register R5 = 0)

Zulu Modem Evaluation Board Schematic

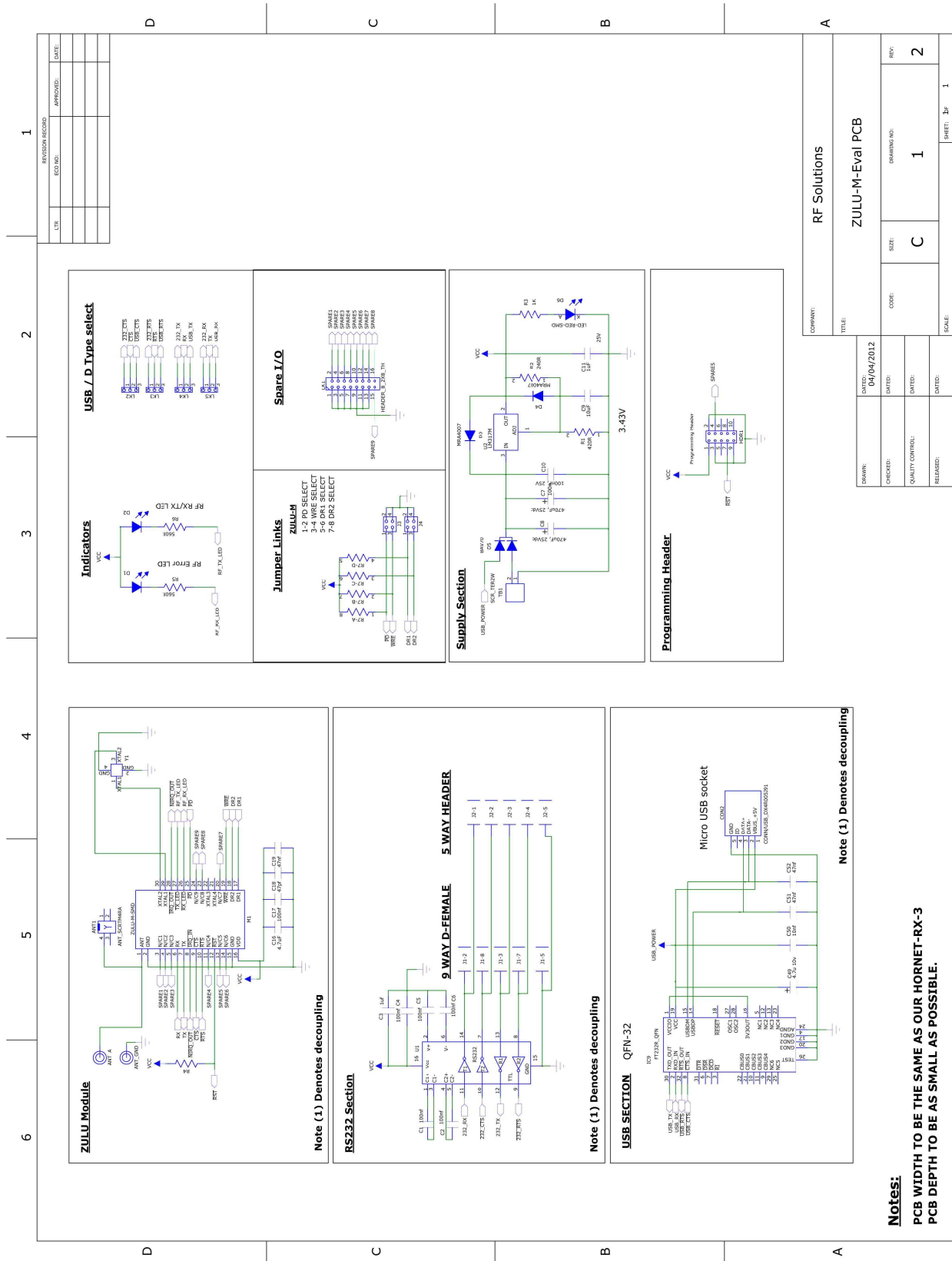

REVISION RECORD	
LTR.	DATE:
ECO NO.	APPROVED:

COMPANY:	RF Solutions
TITLE:	ZULU-M-Eval PCB
DATE:	04/04/2012
SIZE:	C
CODE:	1
DRAWING NO:	2
SCALE:	1

SWORN:	DATE:
CHECKED:	DATE:
QUALITY CONTROL:	DATE:
RELEASED:	DATE:

Notes:
 PCB WIDTH TO BE THE SAME AS OUR HORNET-RX-3
 PCB DEPTH TO BE AS SMALL AS POSSIBLE.

ZULU Modem

Reader Response

It is our intention to provide you with the best documentation possible to ensure successful use of your RF Solutions product.

If you wish to provide your comments on organization, clarity, subject matter, and ways in which our documentation can better serve you, please email us your comments to the Technical Publications Manager

Application:

Would you like a reply? Y / N

Datasheet: DS-ZULUModem-4

Questions:

1. What are the best features of this document?
2. How does this document meet your hardware and software development needs?
3. Do you find the organization of this document easy to follow? If not, why?
4. What additions to the document do you think would enhance the structure and subject?
5. What deletions from the document could be made without affecting the usefulness?
6. Is there any incorrect or misleading information (what and where)?

RF Solutions Ltd. Recycling Notice

Meets the following EC Directives:

DO NOT Discard with normal waste, please recycle.

ROHS Directive 2002/95/EC

Specifies certain limits for hazardous substances.

WEEE Directive 2002/96/EC

Waste electrical & electronic equipment. This product must be disposed of through a licensed WEEE collection point. RF Solutions Ltd., fulfils its WEEE obligations by membership of an approved compliance scheme.

R F Solutions Ltd.,
Unit 21, Cliffe Industrial Estate,
Lewes, E. Sussex. BN8 6JL. England.
Email : sales@rfsolutions.co.uk <http://www.rfsolutions.co.uk>

Tel Sales: 01273 898 020

Tel Technical: 01273 898 007

Tel Gen Enq: 01273 898 000

Whilst the information in this document is believed to be correct at the time of issue, RF Solutions Ltd does not accept any liability whatsoever for its accuracy, adequacy or completeness. No express or implied warranty or representation is given relating to the information contained in this document. RF Solutions Ltd reserves the right to make changes and improvements to the product(s) described herein without notice. Buyers and other users should determine for themselves the suitability of any such information or products for their own particular requirements or specification(s). RF Solutions Ltd shall not be liable for any loss or damage caused as a result of user's own determination of how to deploy or use RF Solutions Ltd's products. Use of RF Solutions Ltd products or components in life support and/or safety applications is not authorised except with express written approval. No licences are created, implicitly or otherwise, under any of RF Solutions Ltd's intellectual property rights. Liability for loss or damage resulting or caused by reliance on the information contained herein or from the use of the product (including liability resulting from negligence or where RF Solutions Ltd was aware of the possibility of such loss or damage arising) is excluded. This will not operate to limit or restrict RF Solutions Ltd's liability for death or personal injury resulting from its negligence.

www.rfsolutions.co.uk

RF Solutions Ltd

Unit 21 Cliffe Industrial Estate, Lewes, East Sussex, United Kingdom, BN8 6JL

Tel. Sales: +44 (0)1273 898 000 • Tech. Support: +44 (0)1273 898 007

