

Date	SYM	REVISION RECORD	AUTH	DR.	CK.
05/14/10	C	DIM. 3.56 WAS 4.57	T.B.	B.S.	
07/15/11	D	UPDATED SPECIFICATION	T.B.	B.S.	
3/07/14	E	REMOVED TIN DIPPED PCB TAILS	T.B.	B.S.	

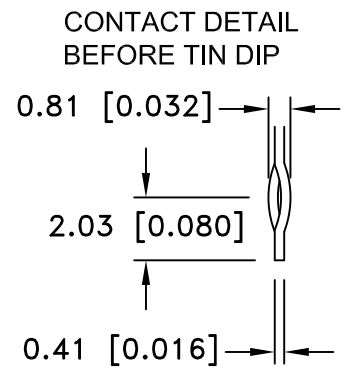
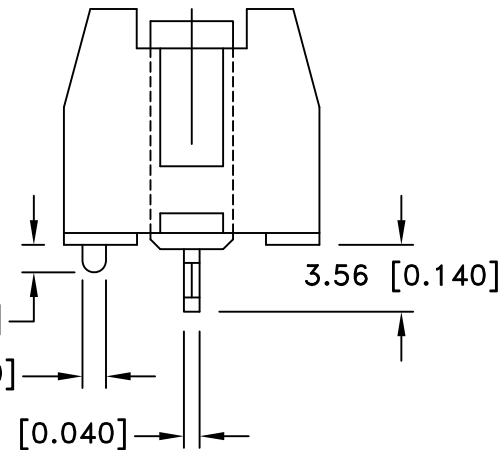
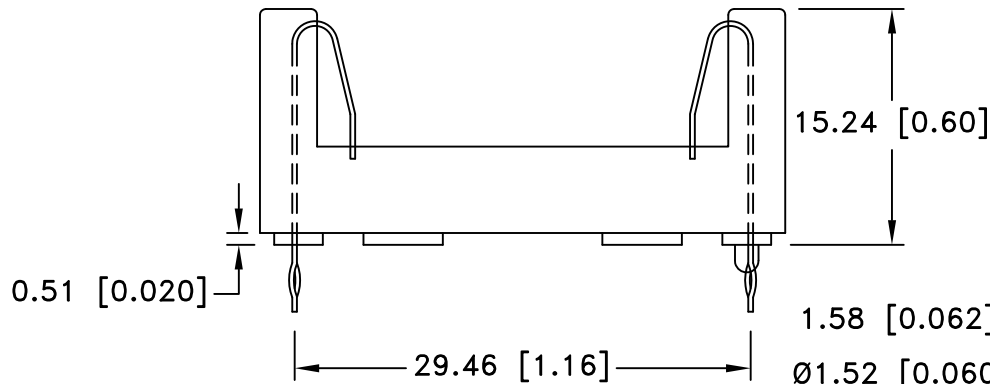
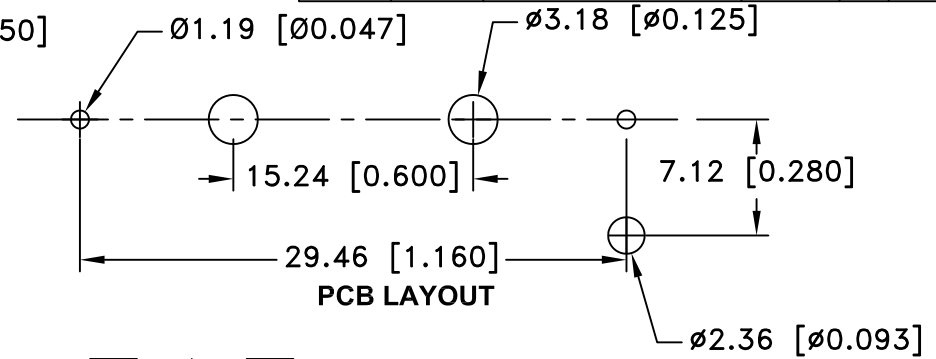

SPECIFICATIONS:

HOLDER MATERIAL: BLACK PBT
 FLAMMABILITY RATING:UL94V-0, FILE #E53829
 CONTACTS: 302 SPRING TEMPER STAINLESS STEEL, NICKEL PLATED OVERALL
 DIELECTRIC STRENGTH: 560 VOLTS/MIL AT 25°C FOR 5 SEC.
 TEMPERATURE RANGE: -55°C TO +180°C
 RESISTANCE TO SOLVENTS: XYLENE, ETHYL , BUTYL, MRTHYL, PROPYL ALCOHOL, ETHYL ACETATE, HEPTANE, TOLUENE, REFRIGERANT

ROHS 2 COMPLIANT

NOTES:

EYELET STIMPSON STYLE#A1883 0.110" OD x 0.190" FLANGE
 FLANGE RECESS Ø0.250" x 0.125" DEEP
 ACCEPTS STANDARD 2-56 MACHINE SCREWS

Tolerance (Except as noted)	 Memory Protection Devices, Inc 200 Broad Hollow Road, Farmingdale, New York 11735		
	decimal ±.5 (.020)	Scale	Drawn By B.S. Approved By T.B.
Fractional ± .8 (.030)	Title 1/2AA BATTERY HOLDER, PCB MOUNTING		
Angular ± 3°	Date 3/07/14	Drawing Number 815-0931	