

BODY: PBT THERMOPLASTIC DIELECTRIC STRENGTH, IN AIR, 125 MILS 490/V-MIL
 PER ASTM D 149 FLAMMABILITY RATING, 94V-0(TESTED THICKNESS) .028 PER UL 94. UL FILE NO. E121562.
 COVER: ABS RESIN R/C 100°(R SCALE) PER ASTM D 785 VICAT SOFTENING TEMP. 90°C PER ASTM D 1525
 FLAMMABILITY RATING, 94V-0(TESTING THICKNESS) .062 PER UL 94. UL FILE NO. E56070
 CONTACTS: #302 SPRING TEMPER STAINLESS STEEL, NICKEL PLATED .0005" MIN THICKNESS, OVERALL
 TYPICAL EYELET: STIMPSON # A1737 .122 O.D.x.230 FLANGE(OR EQUAL)
 ROHS COMPLIANT

Date	SYM	REVISION RECORD	AUTH	DR.	CK.
1/07/06	A	ADDED "ROHS COMPLIANT"	T.B.	B.S.	

BATTERY HOLDER

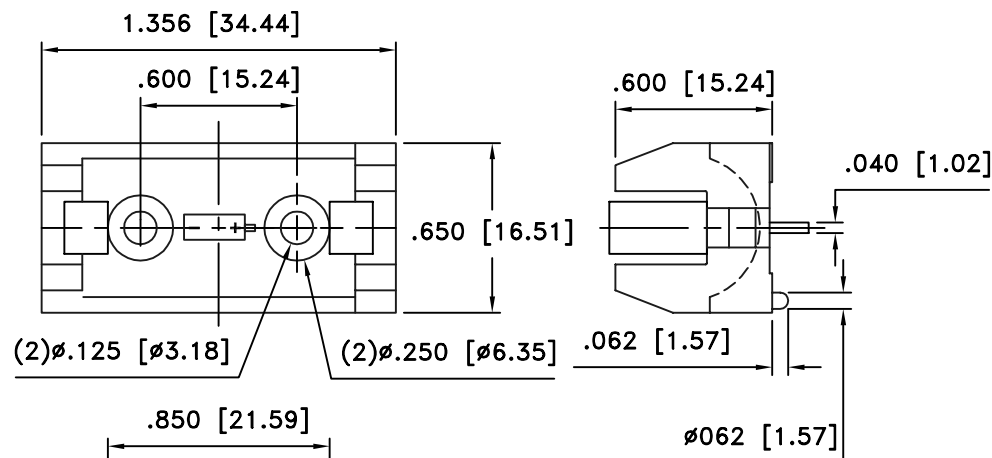
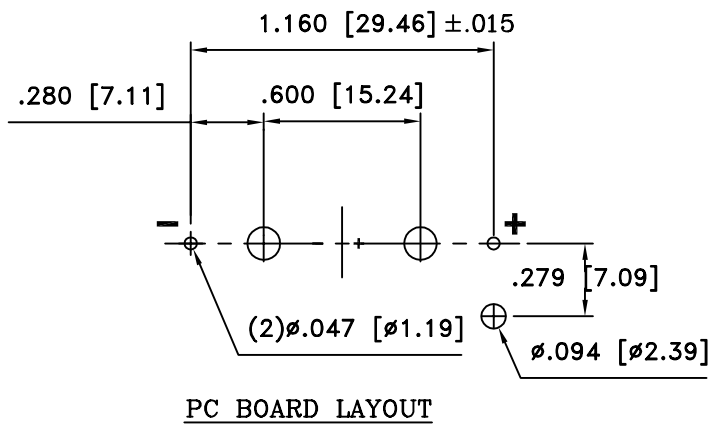

COVER

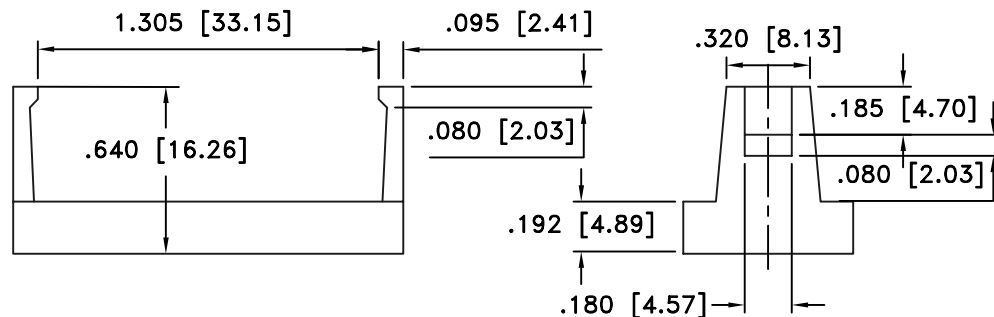
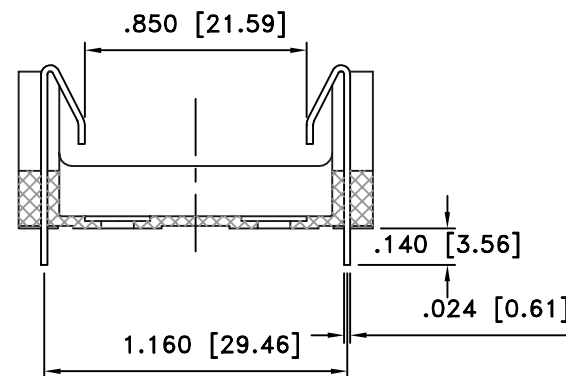
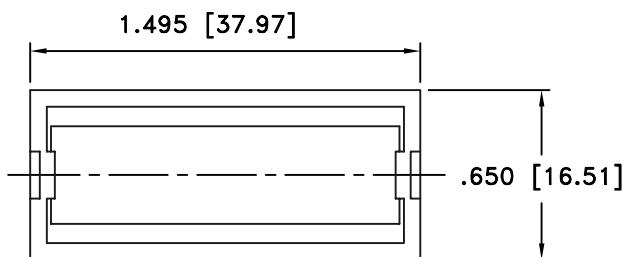

Tolerance (Except as noted)	 Memory Protection Devices, Inc 200 Broad Hollow Road, Farmingdale, New York 11735	Scale	Drawn By T.S.
decimal ±.5 (.020)		2=1	Approved By T.B.
Fractional ± .8 (.030)	Title 1/2 AA HOLDER, ALSO ACCEPTS 6V CELLS LIKE PX28L, 2CRL, L544, K28L (A)		
Angular ± 3°	Date 1/07/06	Drawing Number ABH1/2AA	