

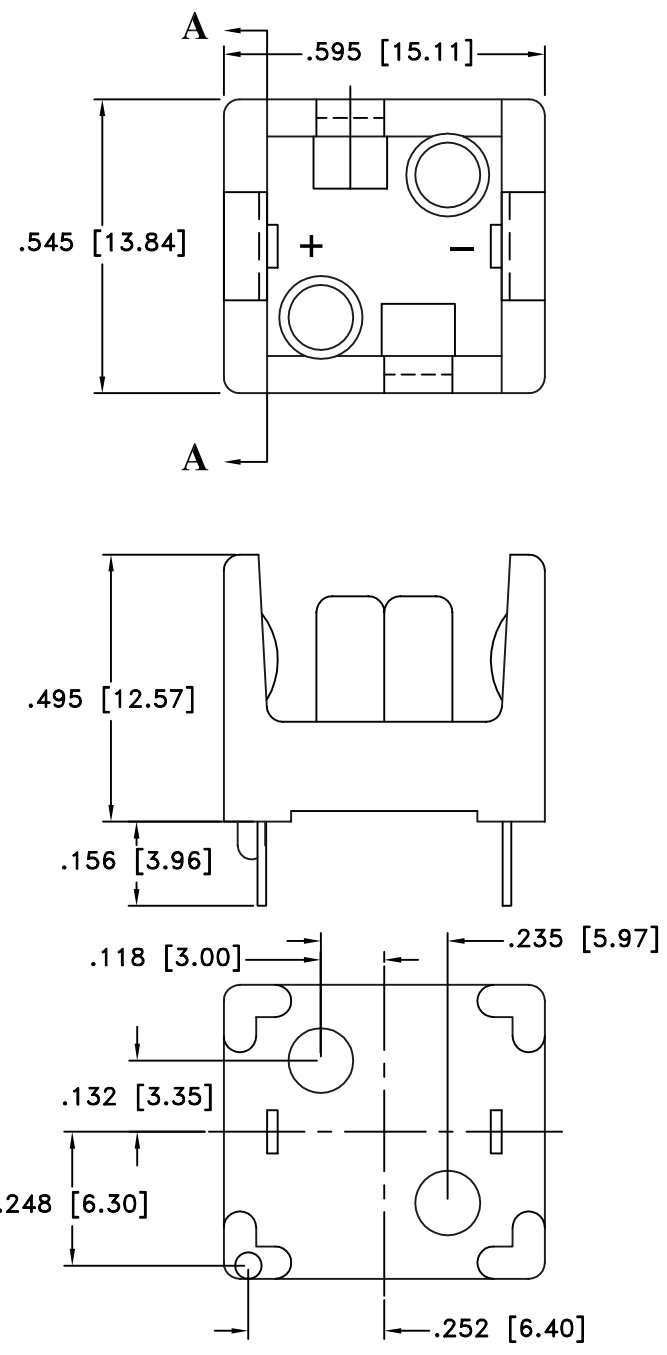

| PART NO. | DESCRIPTION | MATERIAL  |
|----------|-------------|---|
| ABG-190  | HOLDER BODY | PBT, UL94V-0 FILE NO.: E41797,<br>COLOR: BLACK, TEMPERATURE: -55°-+140° |
| ABG-191  | CONTACT     | PHOSPHOR-BRONZE, NICKEL PLATED<br>LEAD FREE SOLDER TAILS                |

| Date     | SYM | REVISION RECORD                         | AUTH | DR.  | CK. |
|----------|-----|---|------|------|-----|
| 02/19/05 | A   | ADDED BOTTOM VIEW AND DELETED SIDE VIEW | T.B. | B.S. |     |
| 03/12/05 | B   | REMOVED Sn-Pb FROM MATERIAL NOTE        | T.B. | B.S. |     |
| 10/22/05 | C   | ADDED "ROHS COMPLIANT"                  | T.B. | B.S. |     |

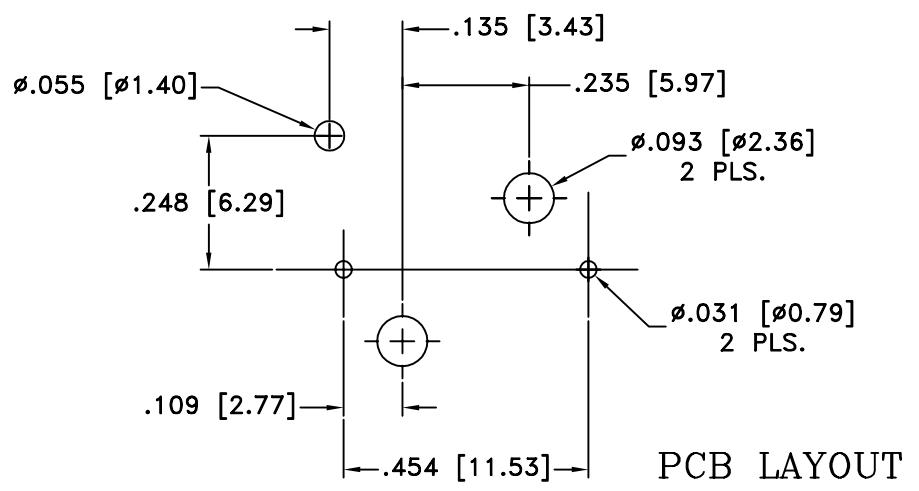

**NOTE:**  
ROHS COMPLIANT



|                                |  |                  |                          |
|--------------------------------|--|------------------|--------------------------|
| Tolerance<br>(Except as noted) |  Memory protection Devices, Inc<br>200 Broad Hollow Road, Farmingdale, New York 11735 | Scale            | Drawn By B.S.            |
|                                |  |                  | Approved By T.B.         |
| decimal<br>±.5 (.020)          | Title<br>BC 1/3N LITHUM BATTERY HOLDER   | Date             |                          |
| Fractional<br>± .8 (.030)      |  | Date<br>10/22/05 | Drawing Number<br>BC1/3N |
| Angular<br>± 3°                |  |                  |                          |