

Date	SYM	REVISION RECORD	AUTH	DR.	CK.
10/22/05	A	ADDED "ROHS COMPLIANT"	T.B.	B.S.	
3/11/06	B	UPDATED MATERIAL SPEC.	T.B.	B.S.	
5/06/06	C	ADDED CONTACT RESI. INFO.	T.B.	B.S.	

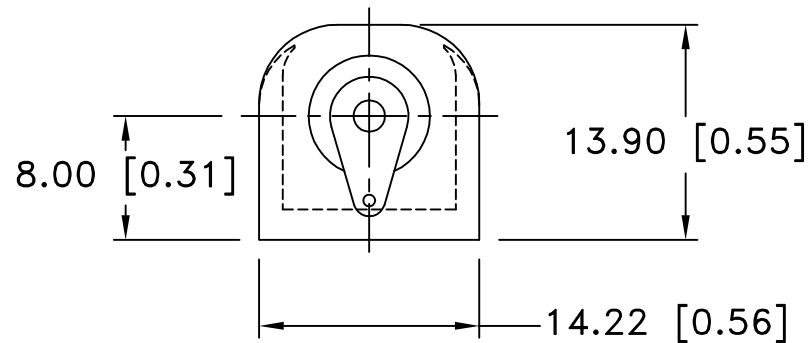
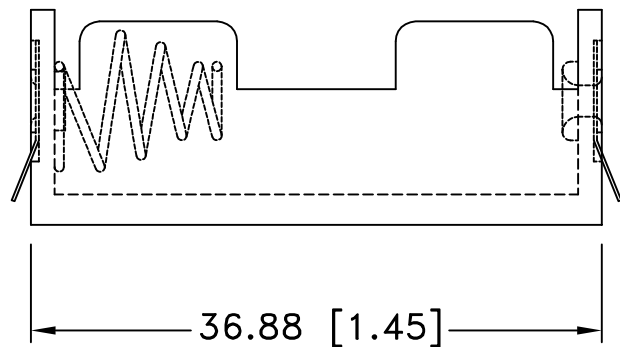
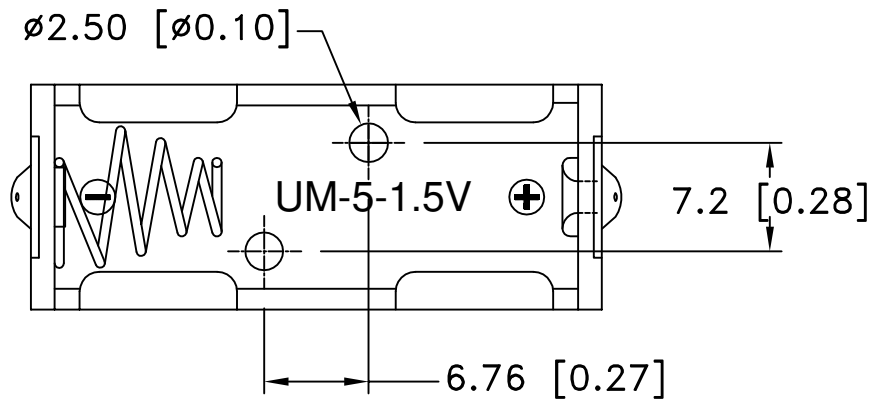

NOTES:

1. MATERIAL:

HOUSING : BLACK POLYPROPYLENE
 FLAMMABILITY RATING -UL94 HB, UL FILE NO. E216959
 TEMPERATURE RANGE: -10°C to +100°C
 RIVETS: BRASS, NICKLE PLTD.
 SPRING: SPRING STEEL, NICKLE PLTD.
 CONTACT RESISTANCE: UNDER 50mΩ FOR +/- CONTACTS PER
 EIA-540J000

ROHS COMPLIANT

Tolerance (Except as noted)	 Memory Protection Devices, Inc 200 Broad Hollow Road, Farmingdale, New York 11735		
decimal $\pm .5$ (.020)	Scale	Drawn By B.S. Approved By T.B.	
Fractional $\pm .8$ (.030)	Title ONE "N" CELL HOLDER		
Angular $\pm 3^\circ$	Date 5/06/06	Drawing Number BHNL	