

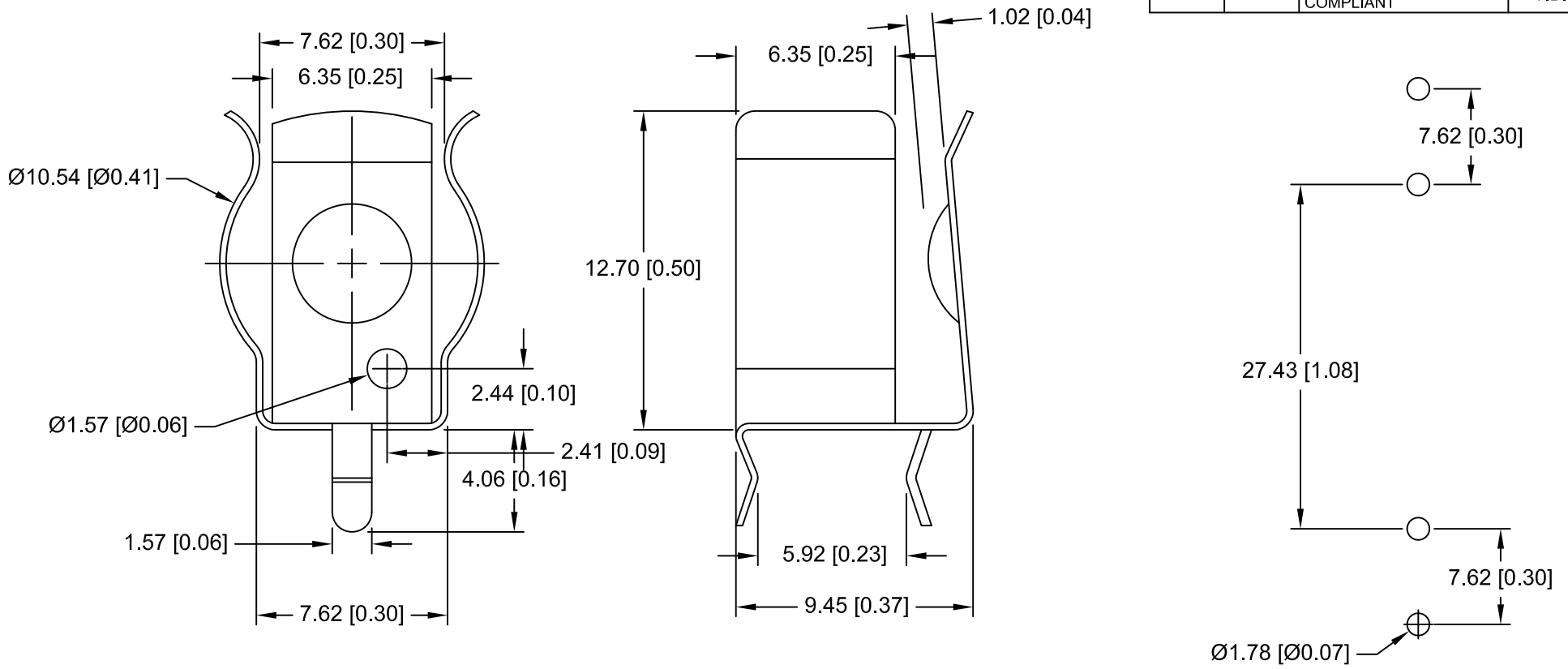

Date	SYM	REVISION RECORD	AUTH	DR.	CK.
11/20/09	A	UPDATED TITLE	T.B.	B.S.	
12/04/09	B	UPDATED PCB LAYOUT	T.B.	B.S.	
2/12/10	C	DIM. 27.43 WAS 28.96	T.B.	B.S.	
10/04/13	D	MATERIAL WAS PHOS. BR.	T.B.	B.S.	
3/07/14	E	UPDATED TO ROHS 2 COMPLIANT	T.B.	B.S.	



PCB LAYOUT FOR APPLICATION

NOTES:

- MATERIAL:
0.010" STEEL 65Mn, NICKEL PLATED
ROHS 2 COMPLIANT

Tolerance (Except as noted)	 Memory Protection Devices, Inc 200 Broad Hollow Road, Farmingdale, New York 11735	Scale	Drawn By B.S.
			Approved By T.B.
decimal $\pm .5$ (.020)	Title PC CLIP FOR AAA BATTERIES	Date 3/07/14	
Fractional $\pm .8$ (.030)		Drawing Number BK-82	
Angular $\pm 3^\circ$			