

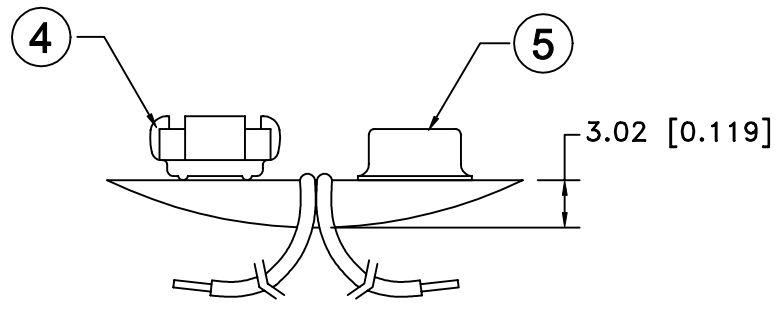

Date	SYM	REVISION RECORD	AUTH	DR.	CK.

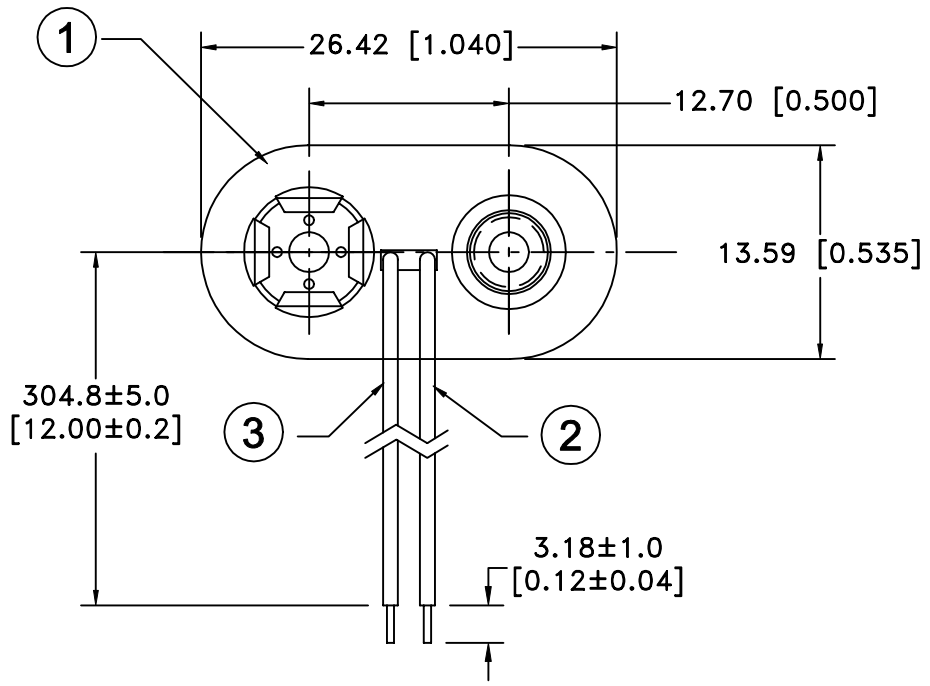

NO.	PART NAME	MATERIAL	QTY.
1	COVER	PVC COVER OVER FIBERBOARD	1
2	BLACK WIRE(-)	24 AWG, UL-1007, CSA TR-64, 300V, 80°C	1
3	RED WIRE (+)	24 AWG, UL-1007, CSA TR-64, 300V, 80°C	1
4	FEMALE SNAP	PHOSPHOR BRONZE, NICKLE PLATED, HEAVY DUTY	1
5	MALE SNAP	BRASS NICKLE PLATED	1

	Memory Protection Devices, Inc 200 Broad Hollow Road, Farmingdale, New York 11735	
	Scale	Drawn By B.S.
Title 9 VOLT BATTERY SNAP-T STYLE, HEAVY DUTY, 12" WIRE LEADS		Approved By T.B.
Tolerance (Except as noted) decimal $\pm .5 (.020)$ Fractional $\pm .8 (.030)$ Angular $\pm 3^\circ$	Date 05/25/01	Drawing Number BS12T-HD