

Date	SYM	REVISION RECORD	AUTH	DR.	CK.
03/29/13	A	UPDATED TO ROHS 2 COMPLIANT	T.B.	B.S.	

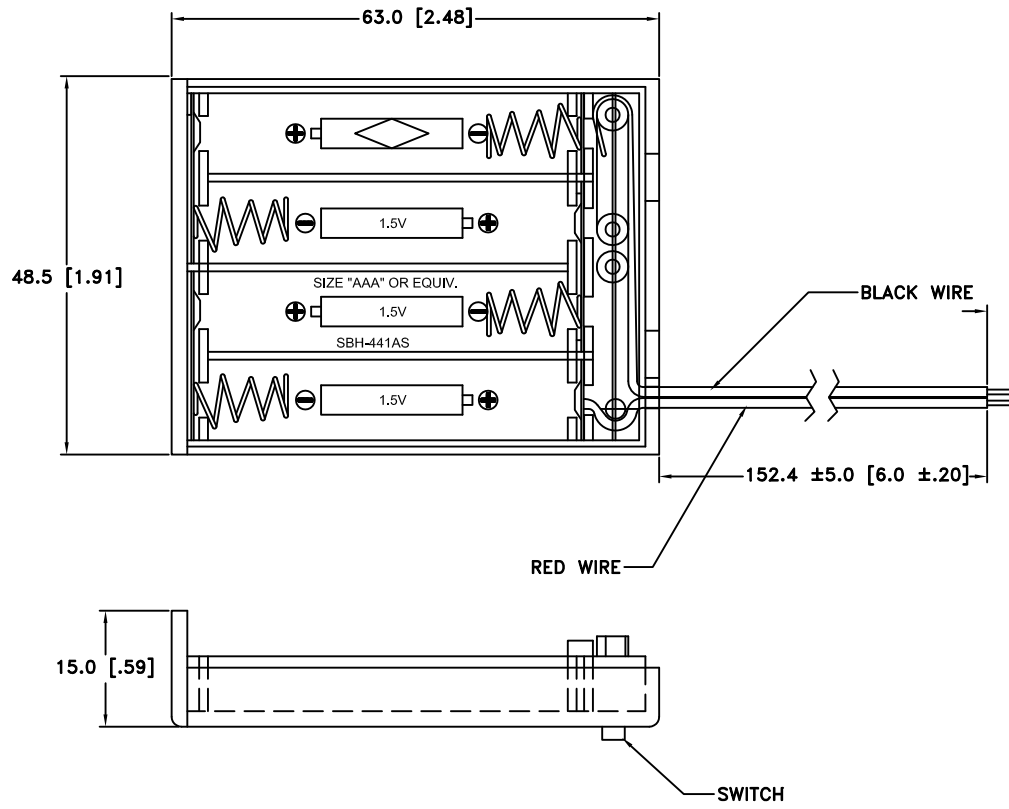

BOTTOM-HOUSING

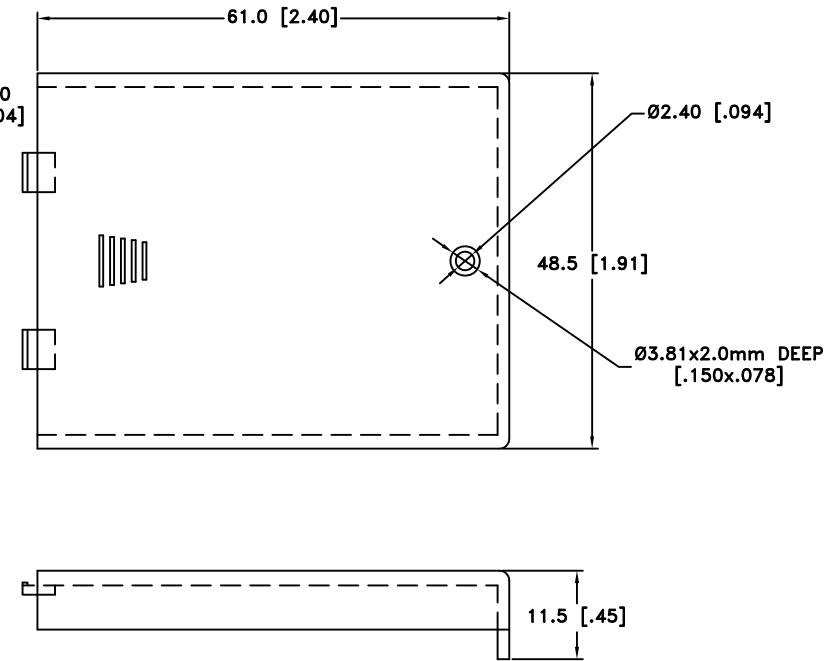

TOP COVER

NOTES:

- ITEM NO. SBH-441AS
- MATERIAL:
 HOUSING AND COVER: BLACK ABS
 WIRE: UL1007, AWG #26, BLACK AND RED-152.4mm LONG,
 STRIPPED AND TINNED- 5mm LONG
 SPRING: 0.5mm, 65C, SPRING WIRE
 ROHS 2 COMPLIANT

Tolerance (Except as noted)	 Memory Protection Devices, Inc 200 Broad Hollow Road, Farmingdale, New York 11735		
decimal ±.5 (.020)	Scale	Drawn By B.S.	
Fractional ± .8 (.030)	Title 4 CELL "AAA" HOLDER WITH COVER AND SWITCH		
Angular ± 3°	Date 03/29/13	Drawing Number SBH-441AS	
		Approved By T.B.	