

Date	SYM	REVISION RECORD	AUTH	DR.	CK.
12/04/09	A	ADDED DIM. 12.1	T.B.	B.S.	
10/22/10	B	ADDED DIM. 3.28 REDRAWN THE TABS	T.B.	B.S.	
12/10/10	C	UPDATED NOTE ON PCB LAYOUT FOR CENTER PAD	T.B.	B.S.	
3/04/11	D	ADDED DIM. 3.30 AND 1.04	T.B.	B.S.	
04/20/12	E	ADDED INSULATOR OUTLINE IN PCB LAYOUT	T.B.	B.S.	

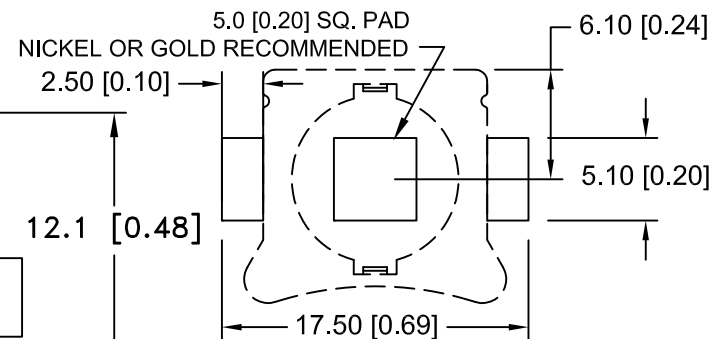

PCB LAYOUT

INSULATOR

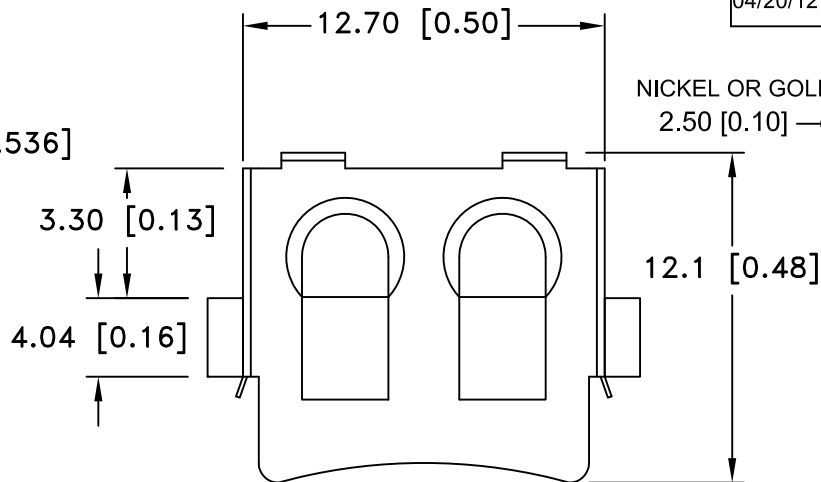
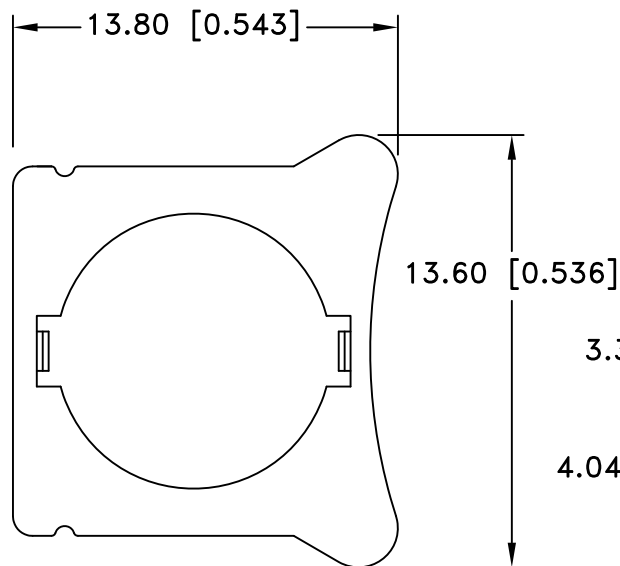
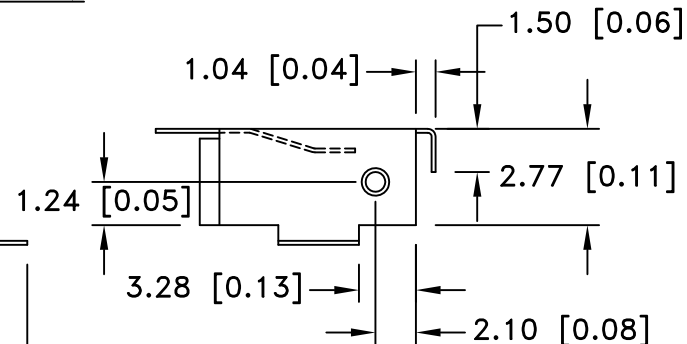
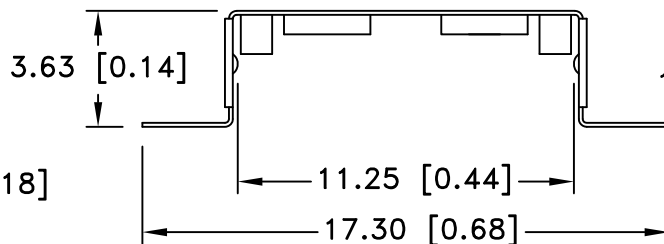
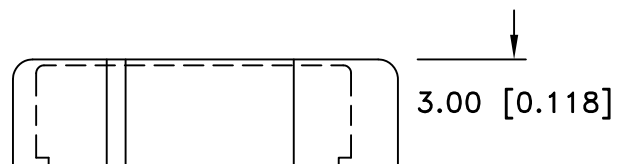

SPECIFICATIONS:

- * Holder material- Polypropylene, AV161 PP, Off White
- * UL Flamability Rating: UL 94-HB File No. E108370
- * Contacts : Phosphor Bronze C5191, Nickel Plated 80-150u thickness
- * Vibration test: 10-50-10 hz swept in 60 seconds
x,y,z direction: 1 hour each direction
- * Result: no dislodgement of the cell or damage
no discontinuity over 10 micro-seconds
- * Shock test: half sine wave acceleration 150g.
6 micro-seconds 3 shock pulses each direction per axis,
total of 18 pulses
- * Result: no evidence of physical damage
- * ROHS COMPLIANT

Tolerance (Except as noted)	 Memory Protection Devices, Inc 200 Broad Hollow Road, Farmingdale, New York 11735	Scale	Drawn By B.S.
		Approved By T.B.	
decimal ±.5 (.020)	Title	CR1025 BATTERY RETAINER WITH INSULATOR	
Fractional ± .8 (.030)	Date	Drawing Number	
Angular ± 3°	04/20/12	BHX1-1025-SM	