

Date	SYM	REVISION RECORD	AUTH	DR.	CK.
2/26/10	C	ADDED RAISED PAD TO PCB LAYOUT	T.B.	B.S.	
12/10/10	D	UPDATED NOTE ON PCB LAYOUT FOR CENTER PAD	T.B.	B.S.	
03/09/12	E	ADDED INSULATOR OUTLINE IN PCB LAYOUT	T.B.	B.S.	

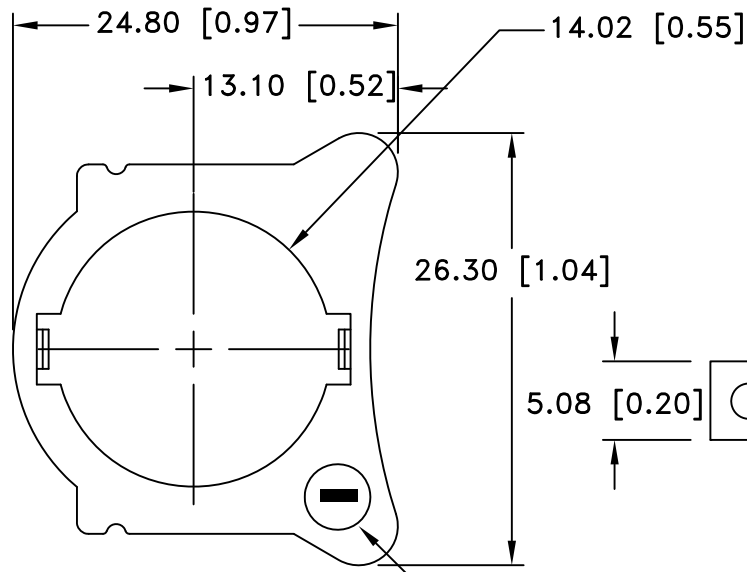

INSULATOR

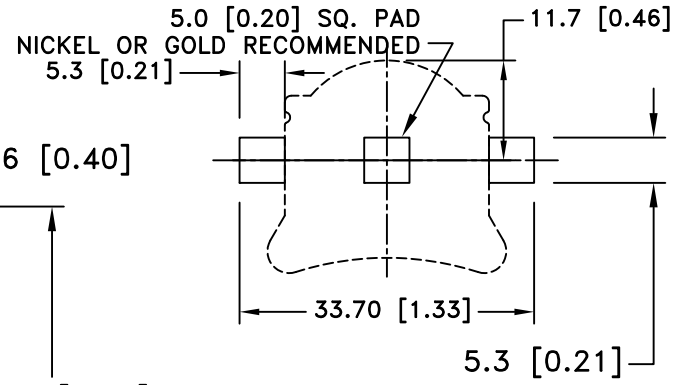
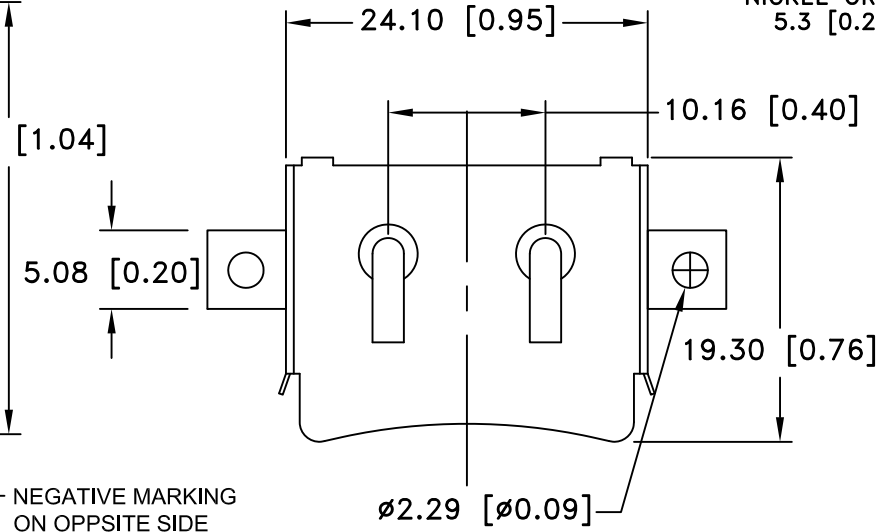

PCB LAYOUT

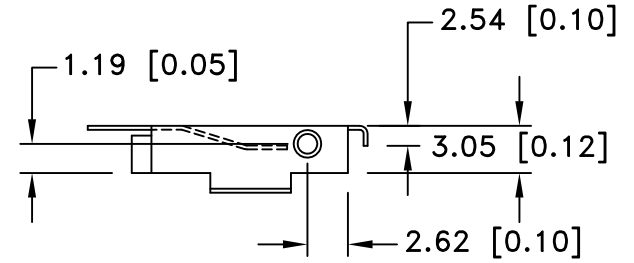
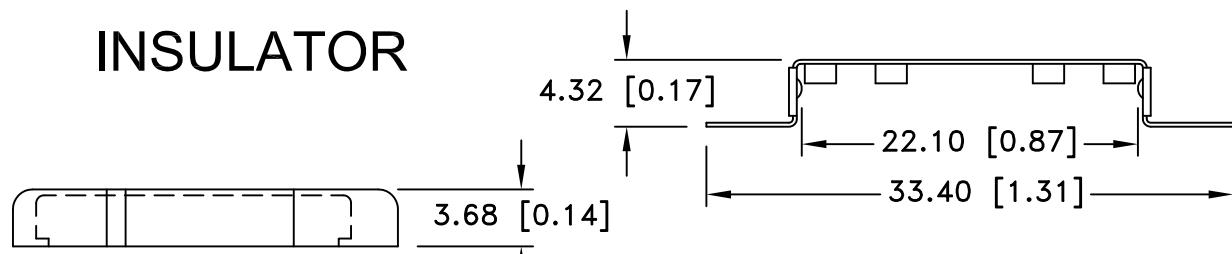

SPECIFICATIONS:

- * Holder material- Polypropylene, AV161 PP, Off White
- * UL Flamability Rating: UL 94-HB File No. E108370
- * Contacts : Phosphor Bronze C5191, Nickel Plated 80-150u thickness
- * Vibration test: 10-50-10 hz swept in 60 seconds
x,y,z direction: 1 hour each direction
- * Result: no dislodgement of the cell or damage
no discontinuity over 10 micro-seconds
- * Shock test: half sine wave acceleration 150g.
6 micro-seconds 3 shock pulses each direction per axis,
total of 18 pulses
- * Result: no evidence of physical damage
- * ROHS COMPLIANT

Tolerance (Except as noted)	 Memory Protection Devices, Inc 200 Broad Hollow Road, Farmingdale, New York 11735	Scale	Drawn By B.S.
			Approved By T.B.
decimal $\pm .5 (.020)$	Title CR2032 SURFACE MOUNT BATTERY RETAINER WITH INSULATOR		
Fractional $\pm .8 (.030)$		Date 03/09/12	Drawing Number BHX1-2032-SM
Angular $\pm 3^\circ$			