

**LED DISPLAY****LTS-4817CTB-P**  
**DATA SHEET**

<b><u>ITEM</u></b>	<b><u>Description</u></b>	<b><u>By</u></b>	<b><u>DATE</u></b>
1	New Spec	Eason Lin	2010/09/23
2	2.1 Modify packing dimensions. 2.2 Modify recommended soldering condition patterns.	Reo Lin	2011/09/21

**FEATURES**

- \* 0.39 inch (10.0 mm) DIGIT HEIGHT
- \* CONTINUOUS UNIFORM SEGMENTS
- \* LOW POWER REQUIREMENT
- \* EXCELLENT CHARACTERS APPEARANCE
- \* HIGH BRIGHTNESS & HIGH CONTRAST
- \* WIDE VIEWING ANGLE
- \* SOLID STATE RELIABILITY
- \* CATEGORIZED FOR LUMINOUS INTENSITY
- \* SMD DISPLAY
- \* **LEAD FREE PACKAGE (ACCORDING TO ROHS)**

**DESCRIPTION**

The LTS-4817CTB-P is a 0.39 inch (10.0 mm) digit height single digit SMD display. This device uses InGaN blue LED chips (InGaN epi on Sapphire substrate). The display has gray face and white segments, and suitable for reverse mount assembly.

**DEVICE**

<b>PART NO.</b>	<b>DESCRIPTION</b>
InGaN Blue	Common Anode
LTS-4817CTB-P	

## PACKAGE DIMENSIONS

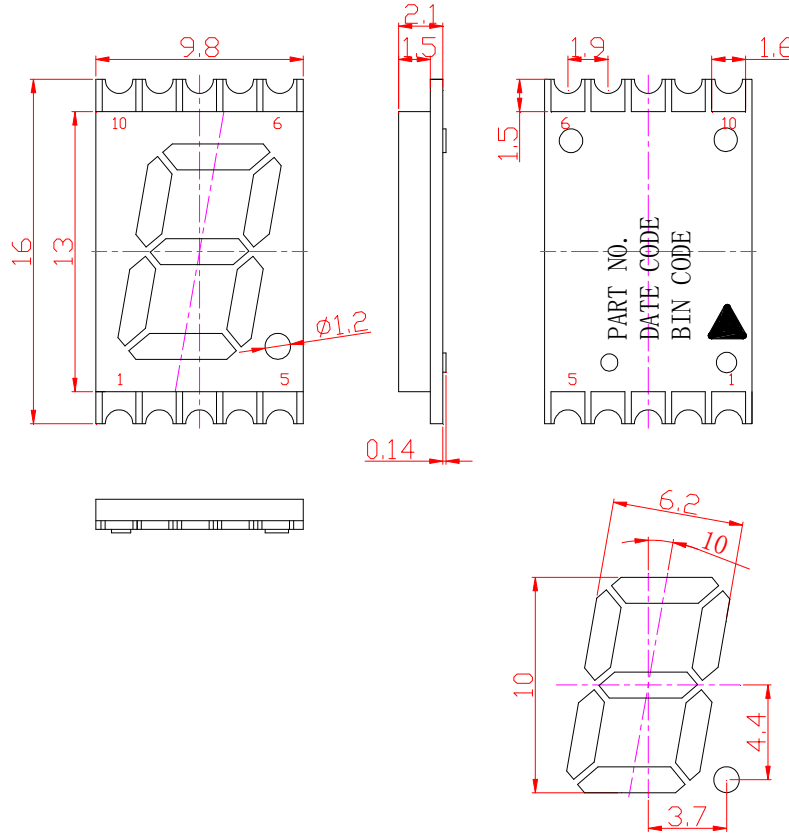

## Solder Pad Vs Painting Diagram

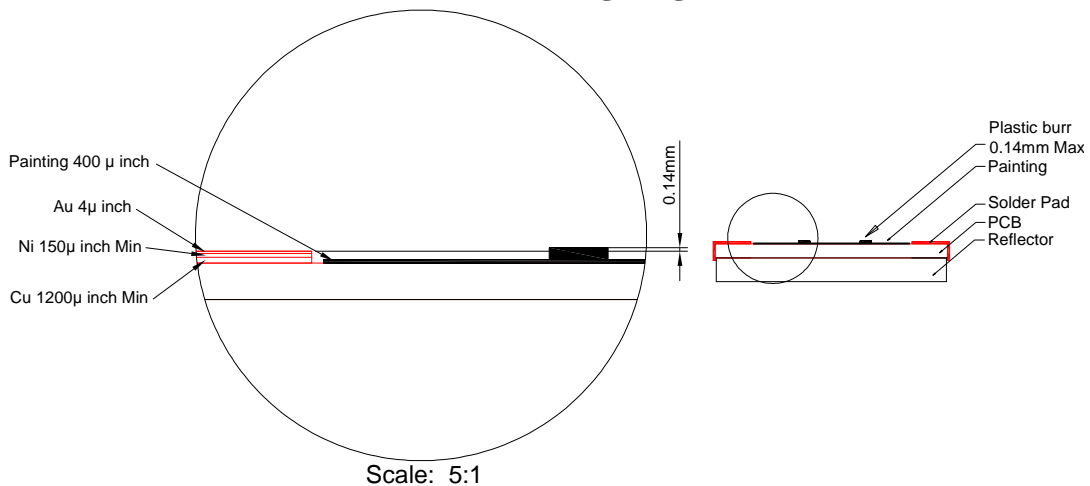

### NOTES:

1. Plastic pins' burr max. 0.14 mm,
2. All dimensions are in millimeters. Tolerances are  $\pm 0.25\text{mm}$  (0.01") unless otherwise noted.
3. Solder pad materials and thickness: Cu:  $1200\ \mu\text{inch}$  Ni: Min  $150\ \mu\text{inch}$  Au:  $4\ \mu\text{inch}$ .

**INTERNAL CIRCUIT DIAGRAM**

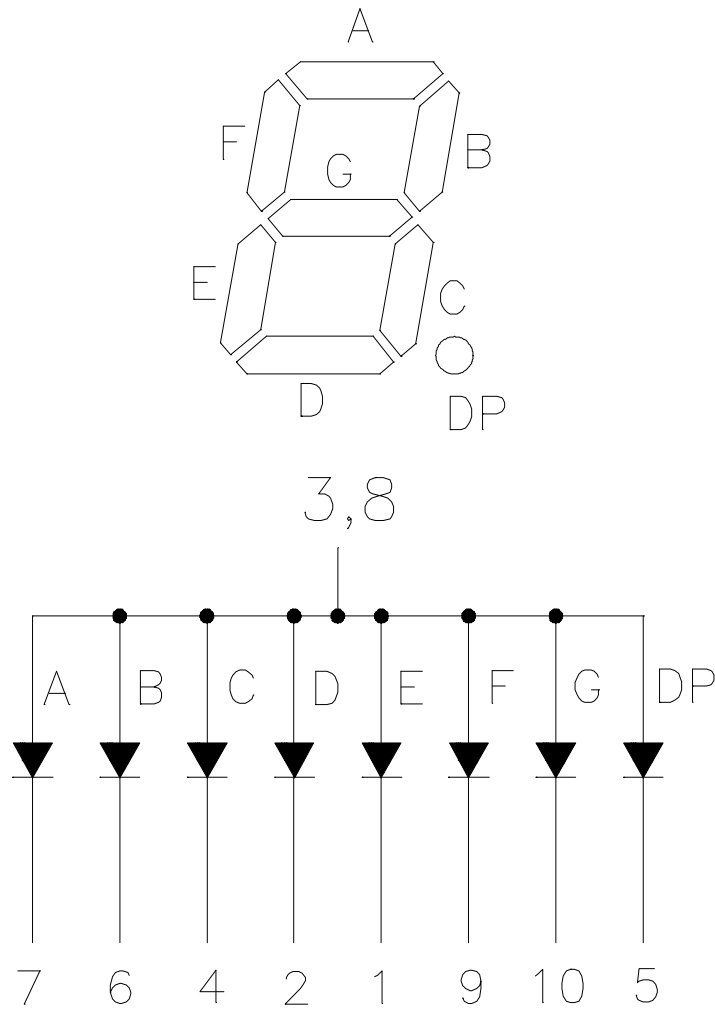

**PIN CONNECTION**

<b>No.</b>	<b>CONNECTION</b>
1	CATHODE E
2	CATHODE D
3	COMMON ANODE
4	CATHODE C
5	CATHODE D.P.
6	CATHODE B
7	CATHODE A
8	COMMON ANODE
9	CATHODE F
10	CATHODE G

**ABSOLUTE MAXIMUM RATING AT Ta = 25°C**

PARAMETER	MAXIMUM RATING	UNIT
Power Dissipation Per Segment	70	mW
Peak Forward Current Per Segment (Frequency 1Khz,10% duty cycle )	100	mA
Continuous Forward Current Per Segment	20	mA
Forward Current Derating from 25 °C	0.21	mA/°C
Operating Temperature Range	-40 °C to +105 °C	
Storage Temperature Range	-40 °C to +105 °C	
Iron Soldering Conditions: 1/16 inch Below Seating Plane for 3 Seconds at 260 °C		

**ELECTRICAL / OPTICAL CHARACTERISTICS AT Ta = 25°C**

PARAMETER	SYMBOL	MIN.	TYP.	MAX.	UNIT	TEST CONDITION
Average Luminous Intensity	I <sub>v</sub>	8.4	26.8		mcd	I <sub>F</sub> = 10mA
Peak Emission Wavelength	λ <sub>p</sub>		468		nm	I <sub>F</sub> = 20mA
Spectral Line Half-Width	Δλ		25		nm	I <sub>F</sub> = 20mA
Dominant Wavelength	λ <sub>d</sub>		470		nm	I <sub>F</sub> = 20mA
Forward Voltage Per Segment	V <sub>F</sub>		3.3	3.6	V	I <sub>F</sub> = 20mA
Reverse Current Per Segment <sup>(2)</sup>	I <sub>R</sub>			100	uA	V <sub>R</sub> = 5V
Luminous Intensity Matching Ratio	I <sub>v</sub> -m			2:1		I <sub>F</sub> = 10mA

Note:

- Luminous intensity is measured with a light sensor and filter combination that approximates the CIE (Commision Internationale De L'Eclairage) eye-response curve.
- Reverse voltage is only for IR test. It can not continue to operate at this situation.

**TYPICAL ELECTRICAL / OPTICAL CHARACTERISTIC CURVES**

(25°C Ambient Temperature Unless Otherwise Noted)

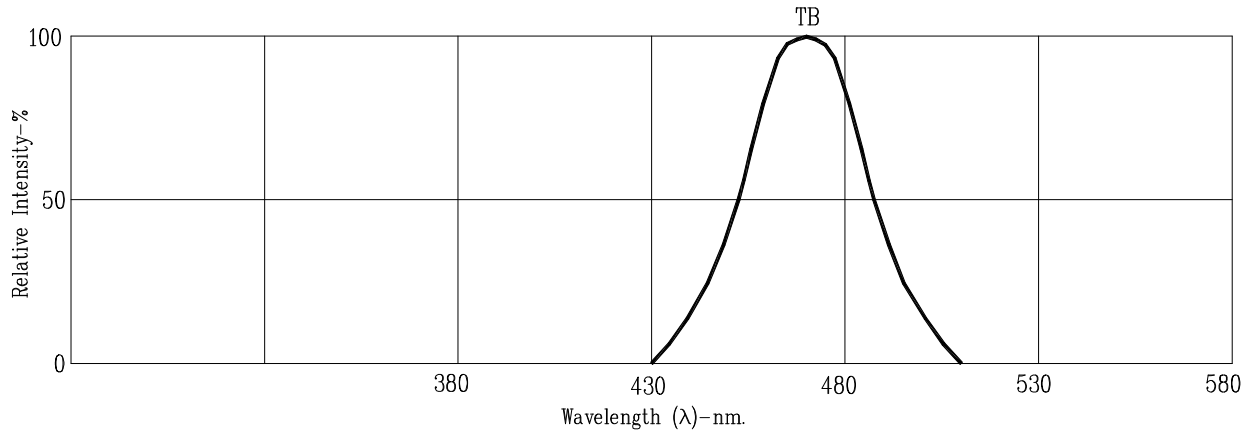

Fig1. RELATIVE INTENSITY VS. WAVELENGTH

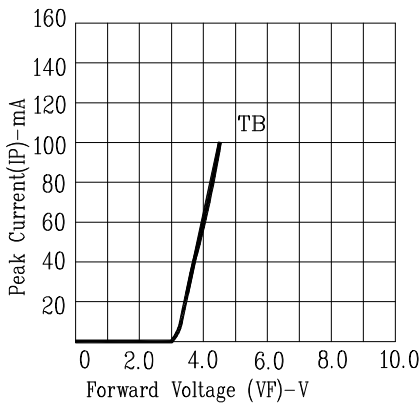

Fig3. FORWARD CURRENT VS. FORWARD VOLTAGE

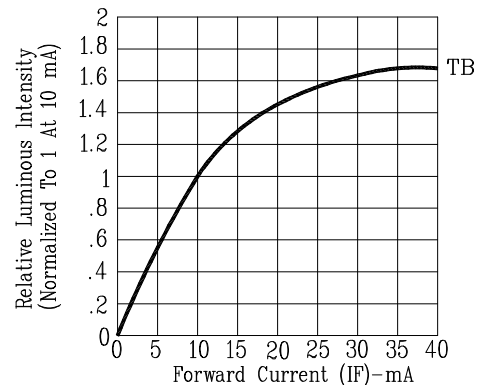

Fig4. RELATIVE LUMINOUS INTENSITY VS. FORWARD CURRENT

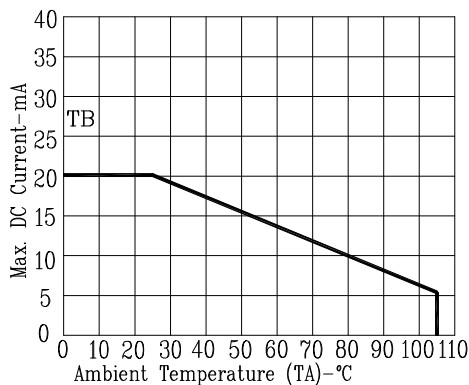

Fig5. MAX. ALLOWABLE DC CURRENT VS. AMBIENT TEMPERATURE.

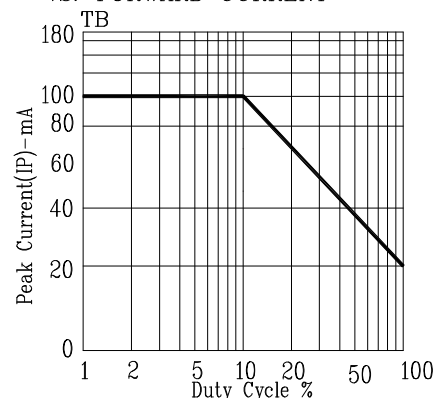
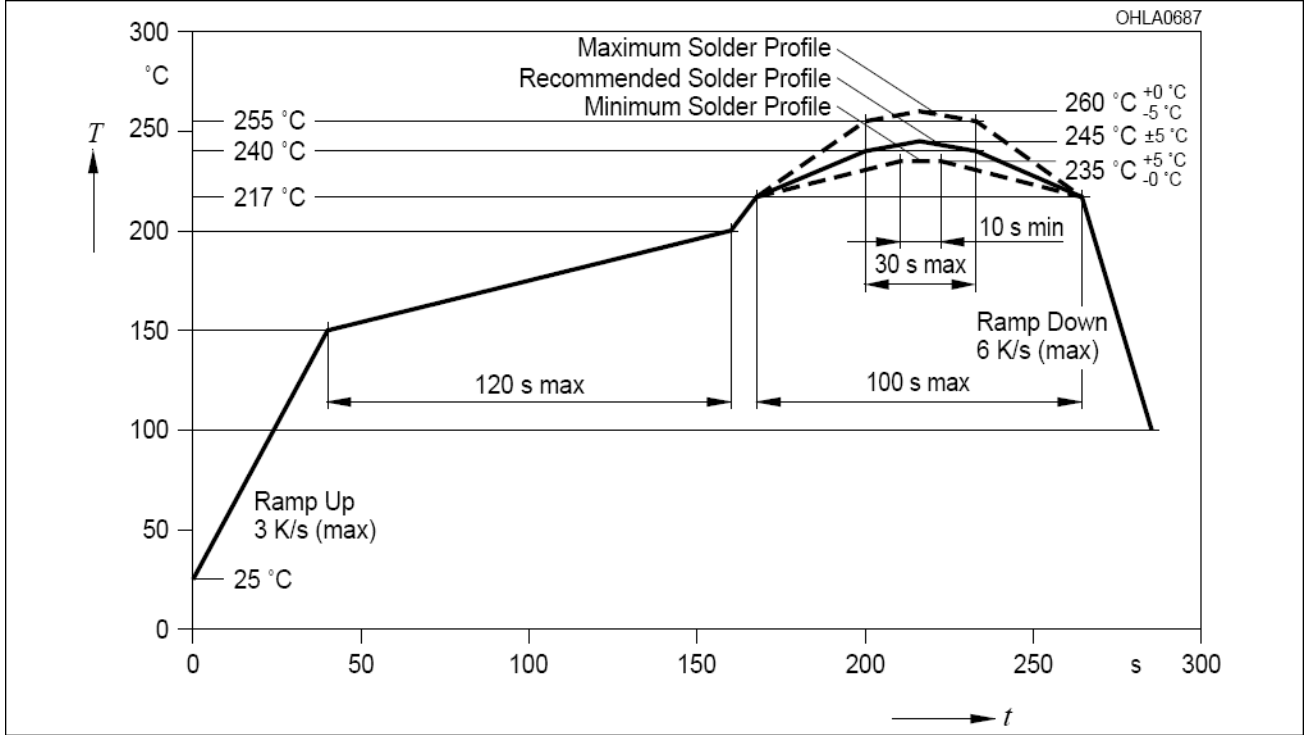

Fig6. MAX. PEAK CURRENT VS. DUTY CYCLE % (REFRESH RATE 1KHz)

NOTE: TB=InGaN/sapphire Blue

**SMT SOLDERING INSTRUCTION**



Note:

1. Recommended soldering condition:

<b>Reflow Soldering (Two times only)</b>		<b>Soldering Iron (One time only)</b>	
Pre-heat:	120~150°C.	Temperature	300°C Max.
Pre-heat time:	120sec. Max.	Soldering time	3sec. Max.
Peak temperature:	260°C Max.		
Soldering time:	5sec. Max.		

2. Number of reflow process shall be less than 2 times, and cooling process to normal temperature is required between the first and the second soldering process.



## RECOMMENDED SOLDERING PATTERN

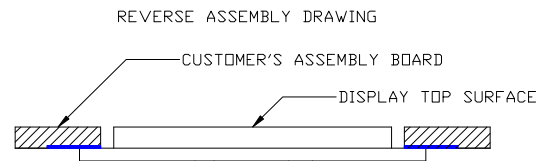
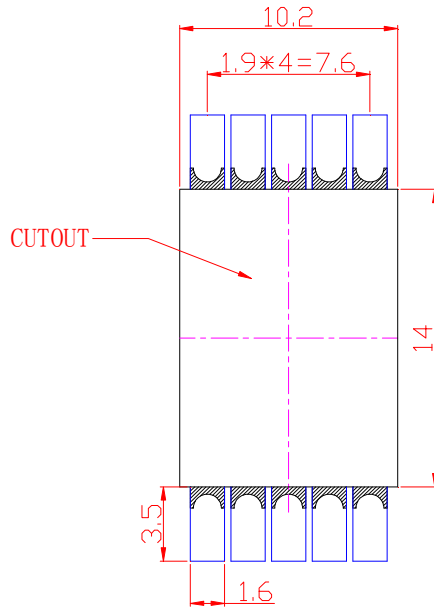

Note: All dimensions are in millimeters.

## PACKING REEL DIMENSIONS

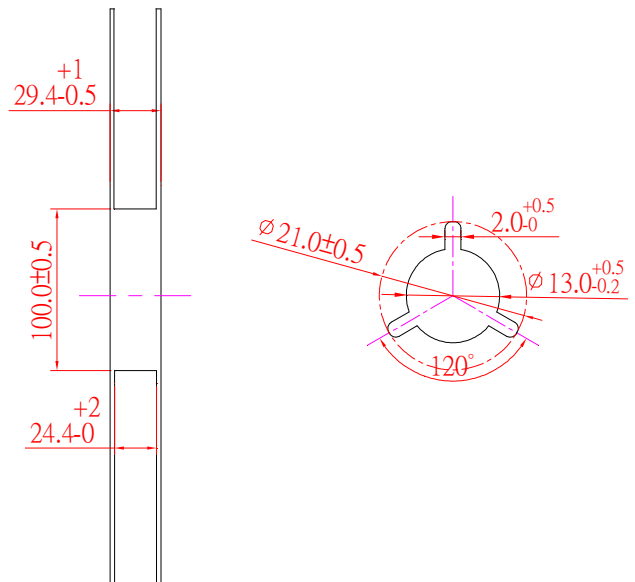
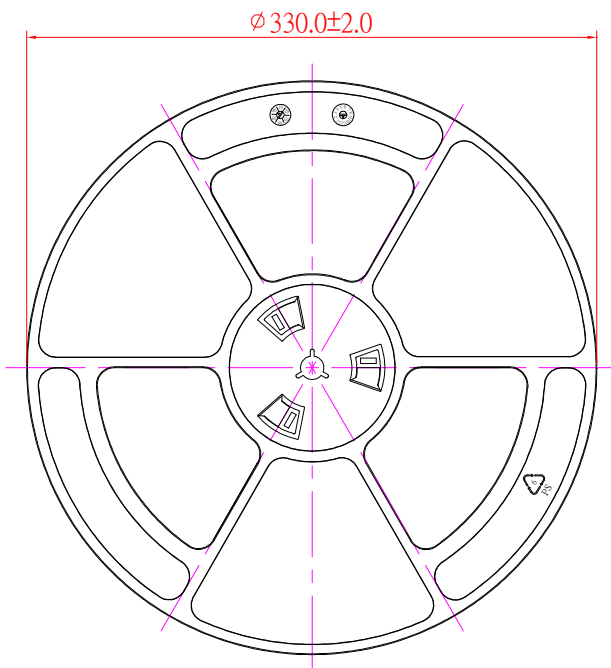

## PACKING CARRIER DIMENSIONS

### 1. Taping parts:

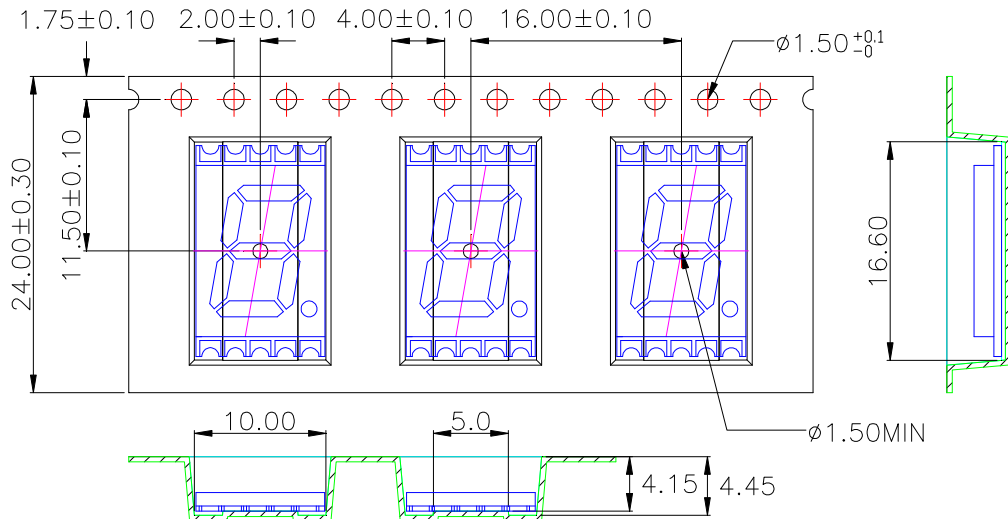

1. 10 sprocket hole pitch cumulative tolerance  $\pm 0.20$ .
2. Carrier camber is within 1 mm in 250 mm.
3. All dimensions meet EIA-481-C requirements.
4. Thickness :  $0.40 \pm 0.05$  mm.
5. Packing length per 22" reel : 45.50 Meters.
6. Component load per 13" reel : 800 pcs.

W	24.00±0.30
A0	10.00±0.10
A1	9.80±0.10
B0	16.60±0.10
B1	16.45±0.10
K0	4.45±0.10
K1	4.15±0.10

### 2. Trailer part/ Leader part:

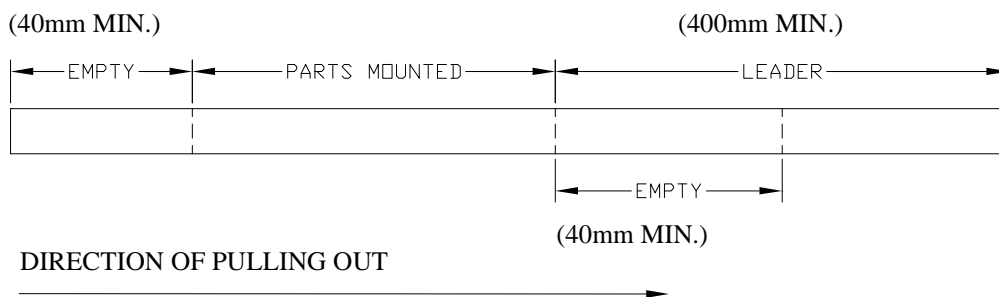

**Moisture Proof Packaging**

All N/D SMD displays are shipped in moisture proof package. The displays should be stored at 30°C or less and 90% RH or less. Once the package opened, moisture absorption begins.

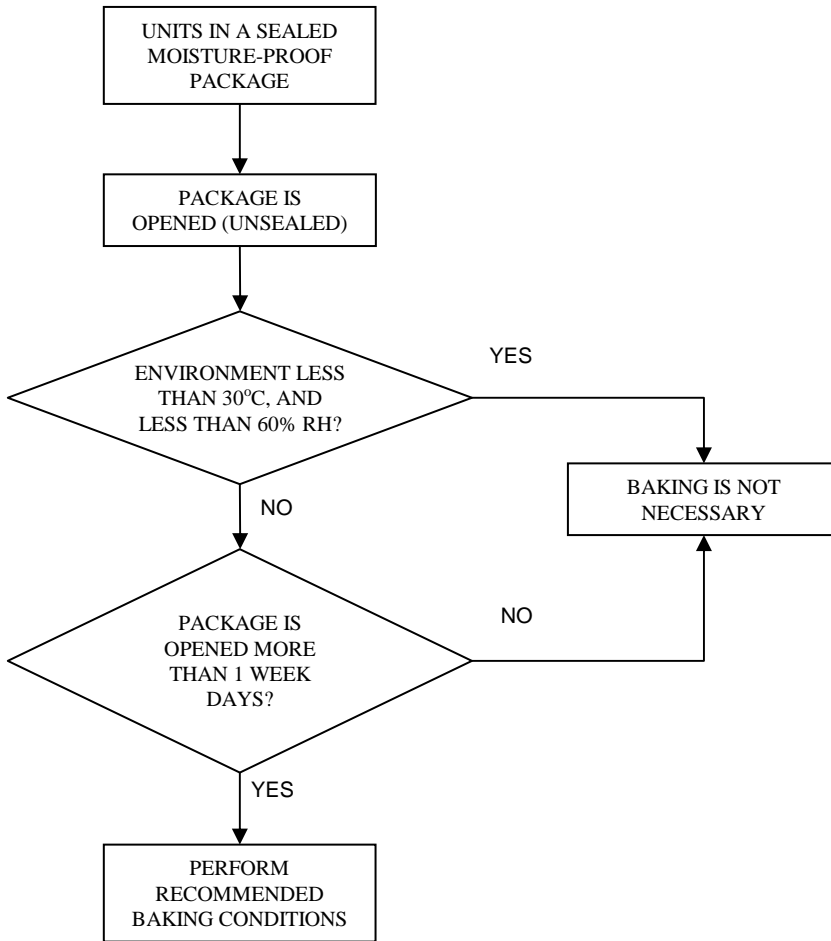

**Baking Conditions**

If the parts are not stored in dry conditions, they must be baked before reflow to prevent damage to the parts.

Package	Temperature	Time
In Reel	60 °C	≥ 48hours
In Bulk	100 °C	≥ 4hours
	125 °C	≥ 2hours

**Baking should only be done once.**