

**LED DISPLAY****LTS-4817CKG-P**  
**DATA SHEET**

<b><u>ITEM</u></b>	<b><u>Description</u></b>	<b><u>By</u></b>	<b><u>DATE</u></b>
1	New Spec	Eason Lin	2010/09/23
2	2.1 Modify packing dimensions. 2.2 Modify recommended soldering condition patterns.	Reo Lin	2011/09/21

**FEATURES**

- \* 0.39 inch (10.0 mm) DIGIT HEIGHT
- \* CONTINUOUS UNIFORM SEGMENTS
- \* LOW POWER REQUIREMENT
- \* EXCELLENT CHARACTERS APPEARANCE
- \* HIGH BRIGHTNESS & HIGH CONTRAST
- \* WIDE VIEWING ANGLE
- \* SOLID STATE RELIABILITY
- \* CATEGORIZED FOR LUMINOUS INTENSITY
- \* SMD DISPLAY
- \* **LEAD FREE PACKAGE (ACCORDING TO ROHS)**

**DESCRIPTION**

The LTS-4817CKG-P is a 0.39 inch (10.0 mm) digit height single digit SMD display. The devices utilize AlInGaP Green LED chips, which are made from AlInGaP on a non-transparent GaAs substrate. The display has gray face and white segments, and suitable for reverse mount assembly.

**DEVICE**

<b>PART NO.</b>	<b>DESCRIPTION</b>
AlInGaP green	Common Anode
LTS-4817CKG-P	

## PACKAGE DIMENSIONS

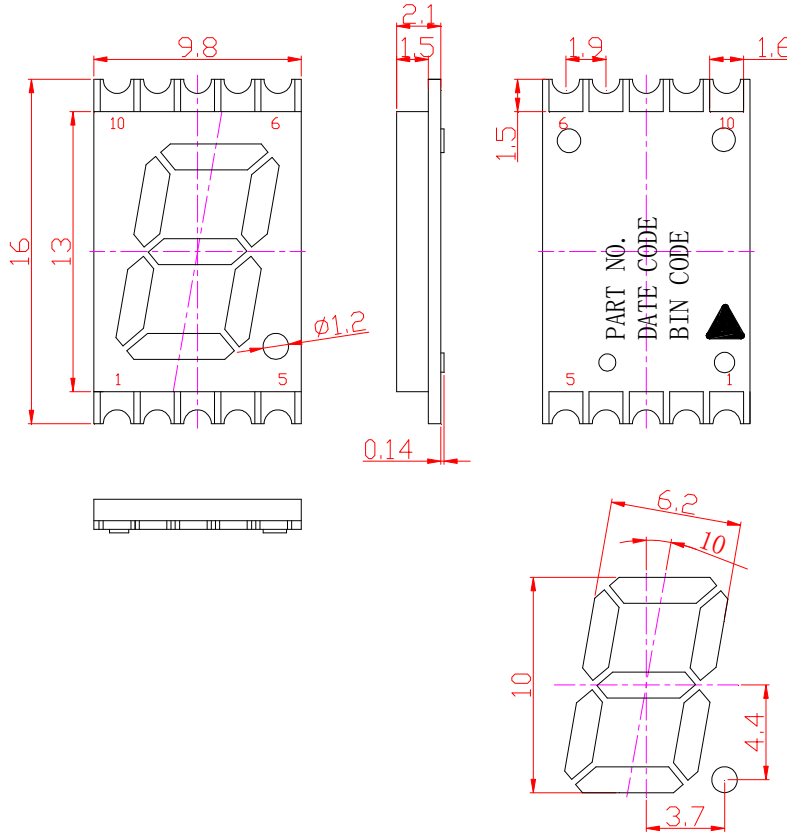

## Solder Pad Vs Painting Diagram

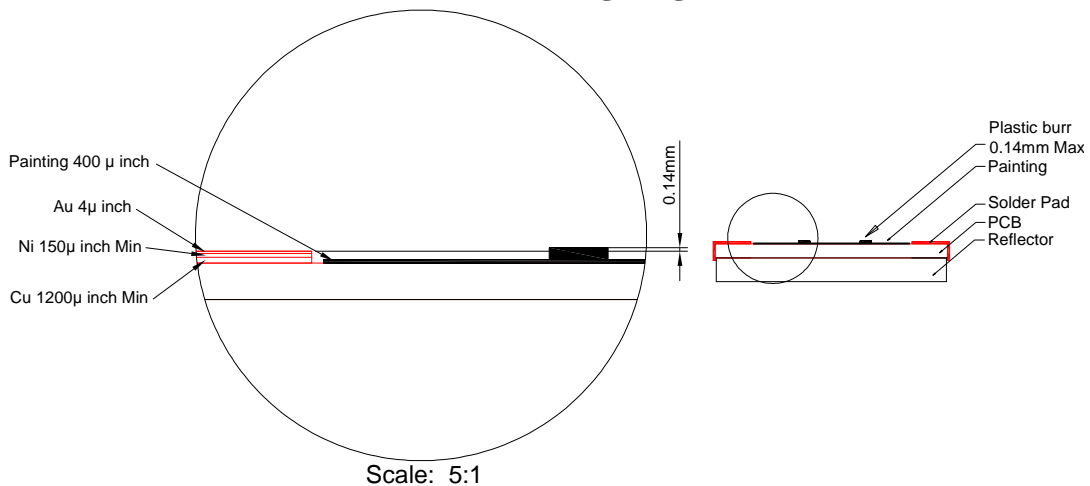

### NOTES:

1. Plastic pins' burr max. 0.14 mm,
2. All dimensions are in millimeters. Tolerances are  $\pm 0.25\text{mm}$  (0.01") unless otherwise noted.
3. Solder pad materials and thickness: Cu:  $1200\ \mu\text{inch}$  Ni: Min  $150\ \mu\text{inch}$  Au:  $4\ \mu\text{inch}$ .

**INTERNAL CIRCUIT DIAGRAM**

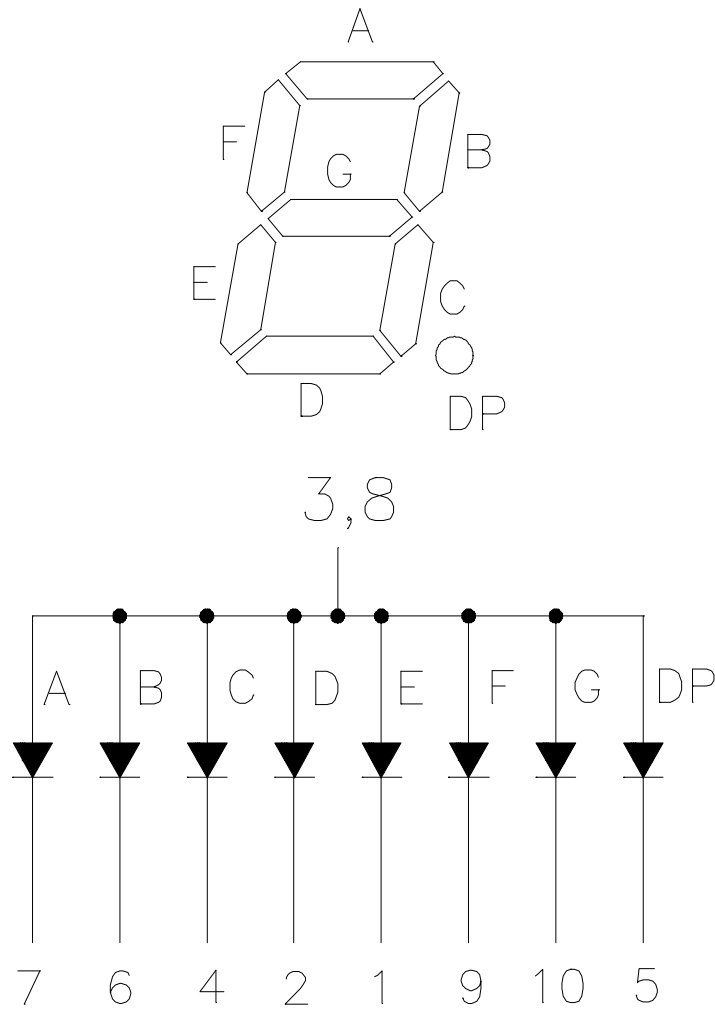

**PIN CONNECTION**

<b>No.</b>	<b>CONNECTION</b>
1	CATHODE E
2	CATHODE D
3	COMMON ANODE
4	CATHODE C
5	CATHODE D.P.
6	CATHODE B
7	CATHODE A
8	COMMON ANODE
9	CATHODE F
10	CATHODE G

**ABSOLUTE MAXIMUM RATING AT Ta = 25°C**

PARAMETER	MAXIMUM RATING	UNIT
Power Dissipation Per Segment	70	mW
Peak Forward Current Per Segment (Frequency 1Khz,10% duty cycle )	60	mA
Continuous Forward Current Per Segment	25	mA
Forward Current Derating from 25°C	0.28	mA/°C
Operating Temperature Range	-40°C to +105°C	
Storage Temperature Range	-40°C to +105°C	
Iron Soldering Conditions: 1/16 inch Below Seating Plane for 3 Seconds at 260°C		

**ELECTRICAL / OPTICAL CHARACTERISTICS AT Ta = 25°C**

PARAMETER	SYMBOL	MIN.	TYP.	MAX.	UNIT	TEST CONDITION
Average Luminous Intensity	I <sub>v</sub>	160	500		μ cd	I <sub>F</sub> = 1mA
Peak Emission Wavelength	λ <sub>p</sub>		571		nm	I <sub>F</sub> = 20mA
Spectral Line Half-Width	Δλ		15		nm	I <sub>F</sub> = 20mA
Dominant Wavelength	λ <sub>d</sub>		572		nm	I <sub>F</sub> = 20mA
Forward Voltage Per Segment	V <sub>F</sub>		2.05	2.6	V	I <sub>F</sub> = 20mA
Reverse Current Per Segment <sup>(2)</sup>	I <sub>R</sub>			100	uA	V <sub>R</sub> = 5V
Luminous Intensity Matching Ratio	I <sub>v</sub> -m			2:1		I <sub>F</sub> = 1mA

Note:

- Luminous intensity is measured with a light sensor and filter combination that approximates the CIE (Commision Internationale De L'Eclairage) eye-response curve.
- Reverse voltage is only for IR test. It can not continue to operate at this situation.

**TYPICAL ELECTRICAL / OPTICAL CHARACTERISTIC CURVES**

(25°C Ambient Temperature Unless Otherwise Noted)

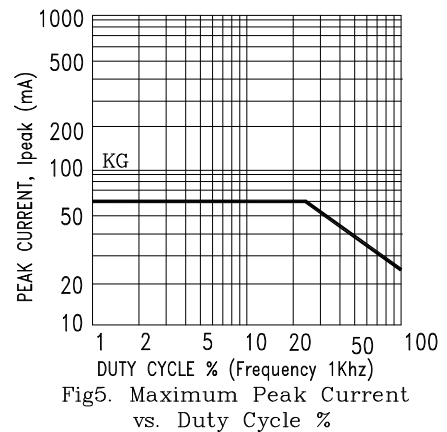
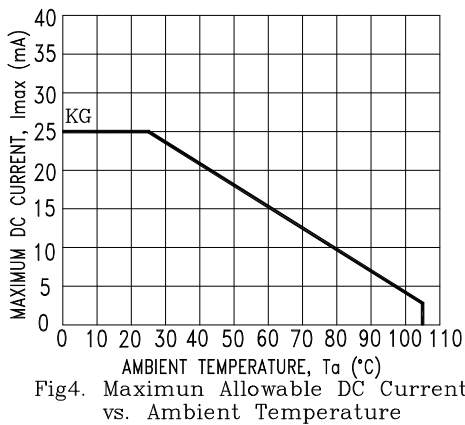
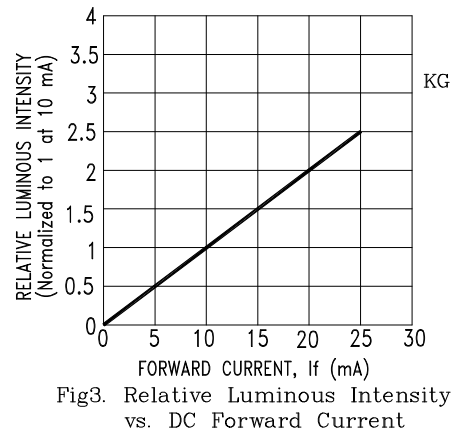
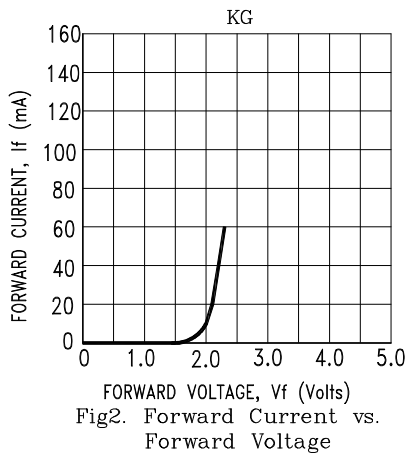
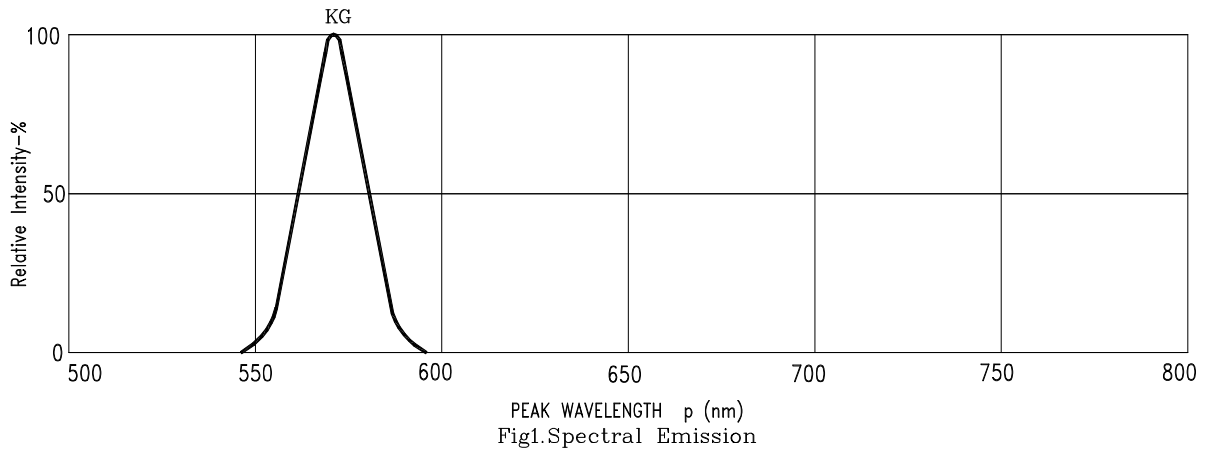

NOTE : KG=AlInGaP Green

**SMT SOLDERING INSTRUCTION**

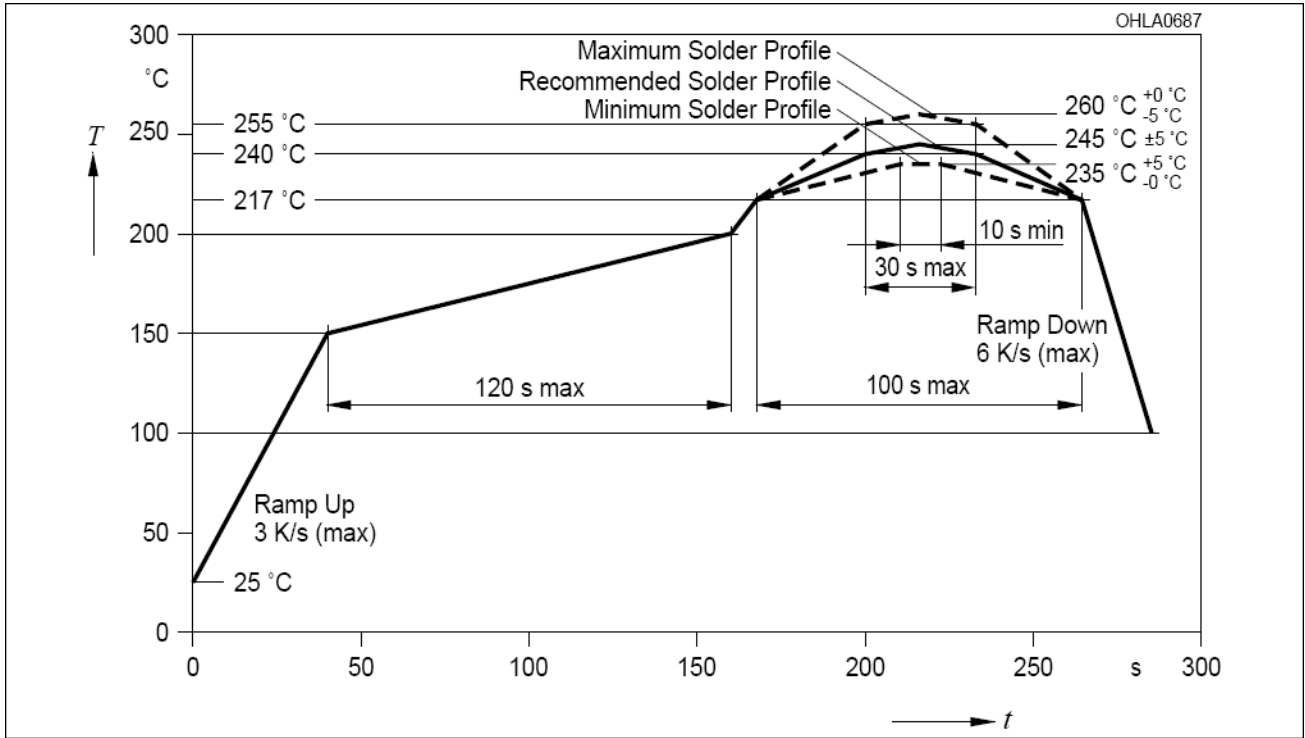

Note:

1. Recommended soldering condition:

Reflow Soldering (Two times only)		Soldering Iron (One time only)	
Pre-heat:	120~150°C.	Temperature	300°C Max.
Pre-heat time:	120sec. Max.	Soldering time	3sec. Max.
Peak temperature:	260°C Max.		
Soldering time:	5sec. Max.		

2. Number of reflow process shall be less than 2 times, and cooling process to normal temperature is required between the first and the second soldering process.



## RECOMMENDED SOLDERING PATTERN

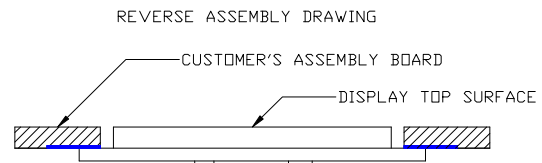
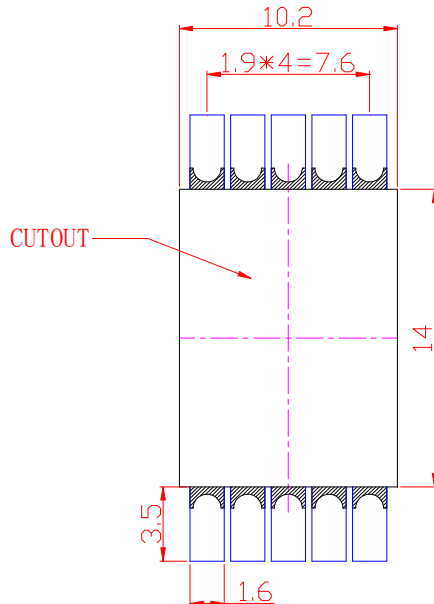

Note: All dimensions are in millimeters.

## PACKING REEL DIMENSIONS

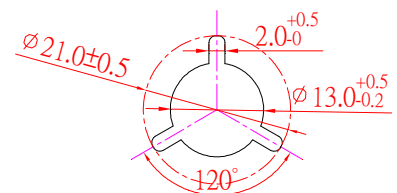
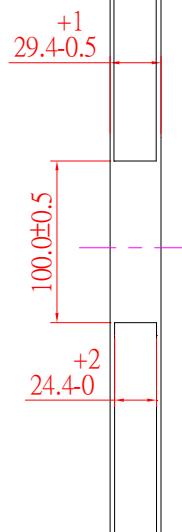
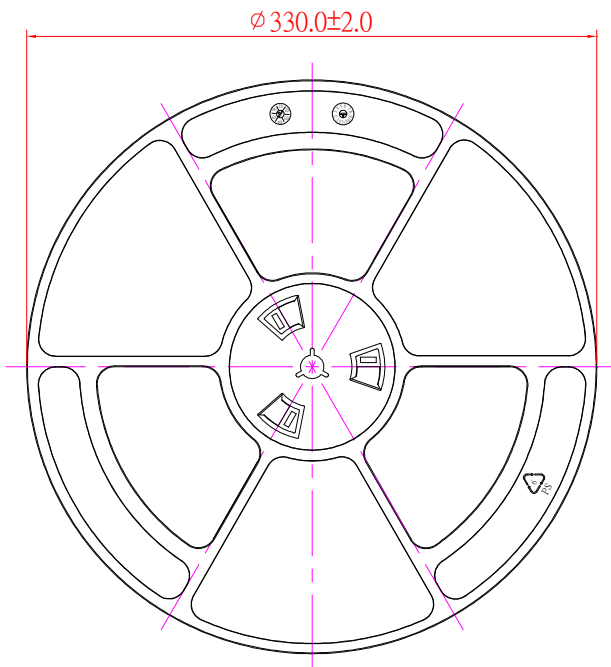

## PACKING CARRIER DIMENSIONS

### 1. Taping parts:

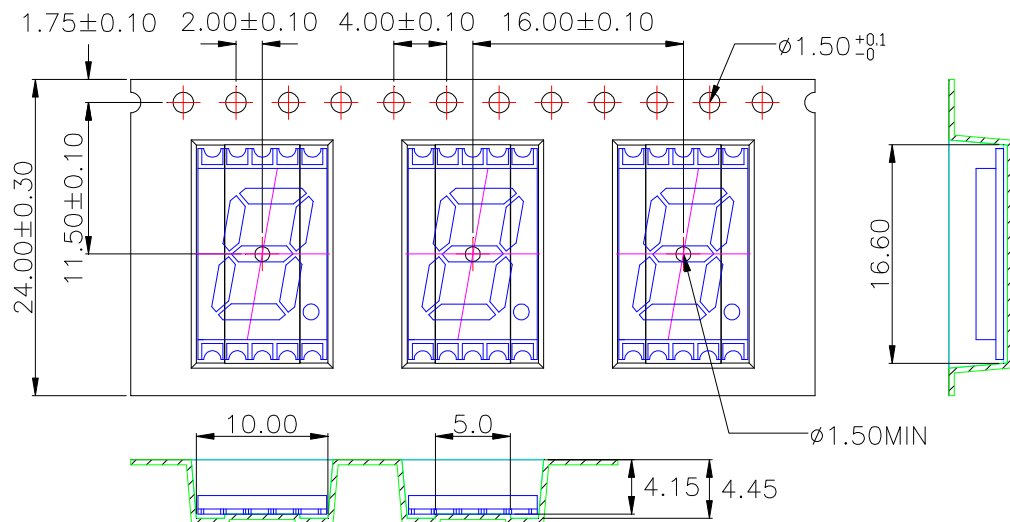

1. 10 sprocket hole pitch cumulative tolerance  $\pm 0.20$ .
2. Carrier camber is within 1 mm in 250 mm.
3. All dimensions meet EIA-481-C requirements.
4. Thickness :  $0.40 \pm 0.05$  mm.
5. Packing length per 22" reel : 45.50 Meters.
6. Component load per 13" reel : 800 pcs.

W	24.00±0.30
A0	10.00±0.10
A1	9.80±0.10
B0	16.60±0.10
B1	16.45±0.10
K0	4.45±0.10
K1	4.15±0.10

### 2. Trailer part/ Leader part:

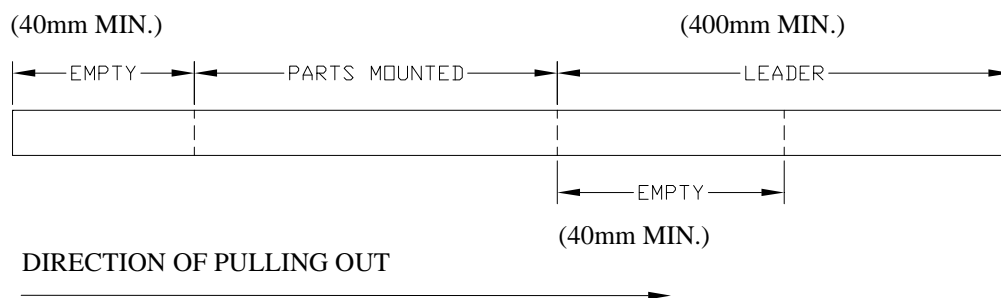

**Moisture Proof Packaging**

All N/D SMD displays are shipped in moisture proof package. The displays should be stored at 30°C or less and 90% RH or less. Once the package opened, moisture absorption begins.

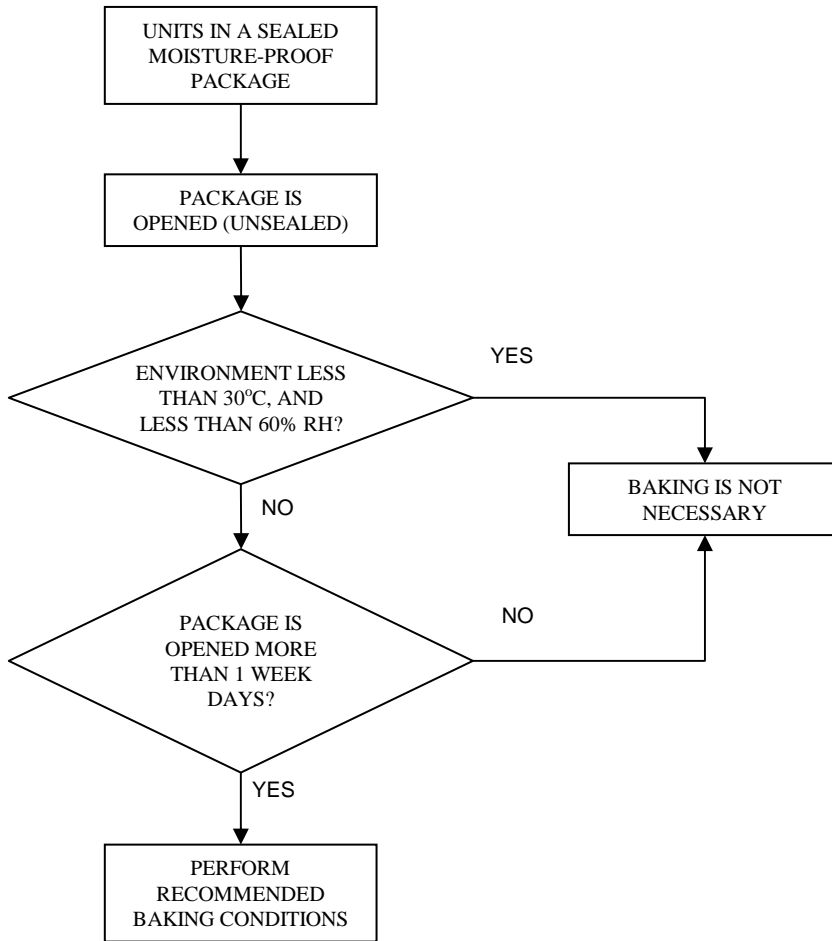

**Baking Conditions**

If the parts are not stored in dry conditions, they must be baked before reflow to prevent damage to the parts.

Package	Temperature	Time
In Reel	60 °C	≥ 48hours
In Bulk	100 °C	≥ 4hours
	125 °C	≥ 2hours

**Baking should only be done once.**