



LED HIGH POWER

P05 Product Series

Data Sheet

Created Date: 03 / 13 / 2013
Revision: 1.4, 06 / 17 / 2013

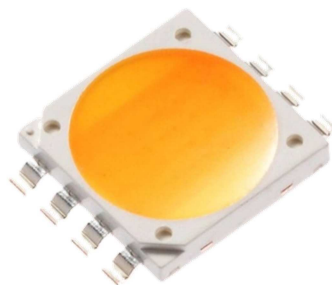

LED HIGH POWER P05 Product Series

1. Description

The LiteON P05 Product series is a revolutionary, energy efficient and ultra compact new light source, combining the lifetime and reliability advantages of Light Emitting Diodes with the brightness of conventional lighting. It gives you total design freedom and unmatched brightness, creating a new opportunities for solid state lighting to displace conventional lighting technologies.

1.1 Features

- Compact high flux density light source
- Uniform high quality illumination
- Streamlined thermal path
- MacAdam compliant binning structure
More energy efficient than incandescent, halogen and fluorescent lamps
- Instant light with unlimited dimming
- RoHS compliant and Pb free
- DC 12V/36V, HV 100V/200V application
- Enhanced optical control
- Clean white light without pixilation
- Uniform consistent white light
- Significantly reduced thermal resistance and increased operating temperatures
- Lower operating costs
- Reduced maintenance costs

1.2 Available Part Numbers

Nominal CCT	Minimum CRI	Forward Voltage	Part Number
2700K	80	100V	LTPL-P05DZS27
3000K	80	100V	LTPL-P05DZS30
2700K	80	12V	LTPL-P05EZS27
3000K	80	12V	LTPL-P05EZS30
4000K	80	12V	LTPL-P05EZS40
5000K	80	12V	LTPL-P05EZS50
5700K	80	12V	LTPL-P05EZS57

LED HIGH POWER P05 Product Series

2. Outline Dimensions

2.1 Form Factor of P05

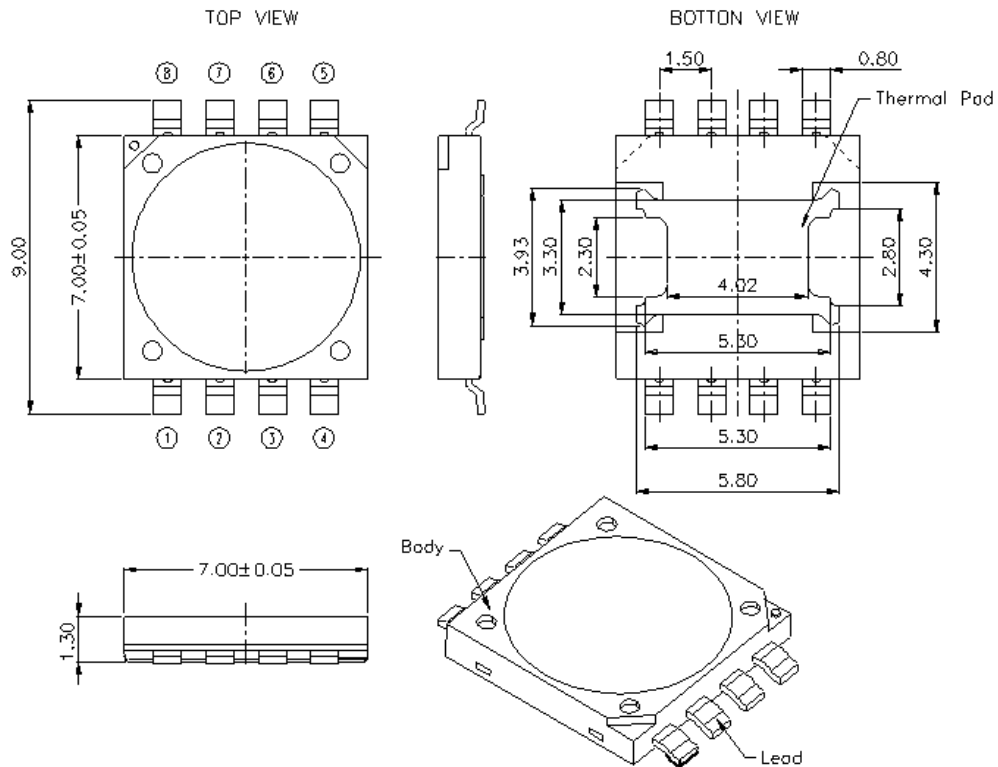

2.2 Internal Equivalent Circuit

2.2.1 LTPL-P05DXXXX

Terminal connections

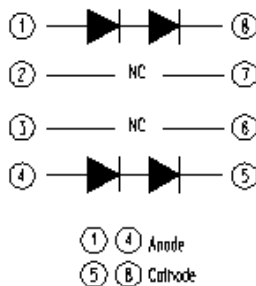

2.2.2 LTPL-P05EXXXX

Terminal connections

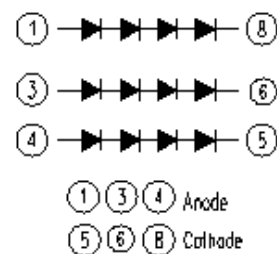

Notes

1. All dimensions are in millimeters.
2. Tolerance is ±0.2 mm (.008") unless otherwise noted.
3. The thermal pad is no polarity.

LED HIGH POWER P05 Product Series

3. Rating and Characteristics

3.1 Absolute Maximum Ratings at Ta=25°C.

Parameter	Symbol	Rating	Unit
Power Dissipation (100V)	P _o	6.5	W
Power Dissipation (12V)	P _o	7.5	W
DC Forward Current (100V)	I _F	60	mA
DC Forward Current (12V)	I _F	540	mA
ESD Sensitivity	V _B	2	kV
Junction Temperature	T _j	125	°C
Thermal Resistance, Junction-Case	R _{th, J-C}	3.0	°C / W
Operating Temperature Range	T _{opr}	-40~+85	°C
Storage Temperature Range	T _{stg}	-55~+100	°C

Notes :

1. The pulse mode condition is 1 KHz with 0.1msec pulse width..
2. Forbid to operating at reverse voltage condition
3. ESD spec is reference to AEC-Q101-001 HBM.
4. The unit of R_{th} is °C/W electrical.
5. Thermal resistance measurement tolerance is ± 10%

LED HIGH POWER P05 Product Series

3.2 Electro-Optical Characteristics

■ LTPL-P05DXXXX

Nominal CCT	Minimum CRI	Current (mA)	Typ. VF (V) @ 25°C	Typ. Flux(lm) @ 25°C	Typ. VF (V) @ 85°C	Typ. Flux(lm) @ 85°C	Eff.(lm/W) @ 25°C	Eff.(lm/W) @ 85°C
2700K	80	40mA	100	330	94	297	82.5	79.0
3000K	80	40mA	100	350	94	315	87.5	83.8

■ LTPL-P05EXXXX

Nominal CCT	Minimum CRI	Current (mA)	Typ. VF (V) @ 25°C	Typ. Flux(lm) @ 25°C	Typ. VF (V) @ 85°C	Typ. Flux(lm) @ 85°C	Eff.(lm/W) @ 25°C	Eff.(lm/W) @ 85°C
2700K	80	350	12	419	11.6	377	99.8	92.6
3000K	80	350	12	440	11.6	396	104.8	97.2
4000K	80	350	12	461	11.6	415	109.8	101.8
5000K	80	350	12	499	11.6	449	118.7	110.2
5700K	80	350	12	482	11.6	434	114.7	106.5

Notes

- P05 maintains a tolerance of $\pm 7\%$ on flux and power measurement.
- LEDs are lighted up and measured with externally parallel connecting leads of LED.
- Luminous flux is the total luminous flux output as measured with an integrating sphere.
- The chromaticity coordinates (x, y) is derived from the CIE 1931 chromaticity diagram.
- IS CAS140B is for the luminous flux (lm) and the CIE1931 chromaticity coordinates (x, y) testing. The chromaticity coordinates (x, y) guarantee should be added ± 0.01 tolerance.
- P05 maintains a tolerance of $\pm 3\%$ on voltage measurement.
- P05 maintains a tolerance of ± 3 on color rendering index measurement.
- LTPL-P05DXXXX: test current is 20mA/string and VF is average test value.
- LTPL-P05EXXXX: test current is 116.7mA/string and VF is average test value.

LED HIGH POWER P05 Product Series

4. Typical Electrical/Optical Characteristics Curve

4.1 Relative Flux vs. Current of LTPL-P05DXXXX at 25°C

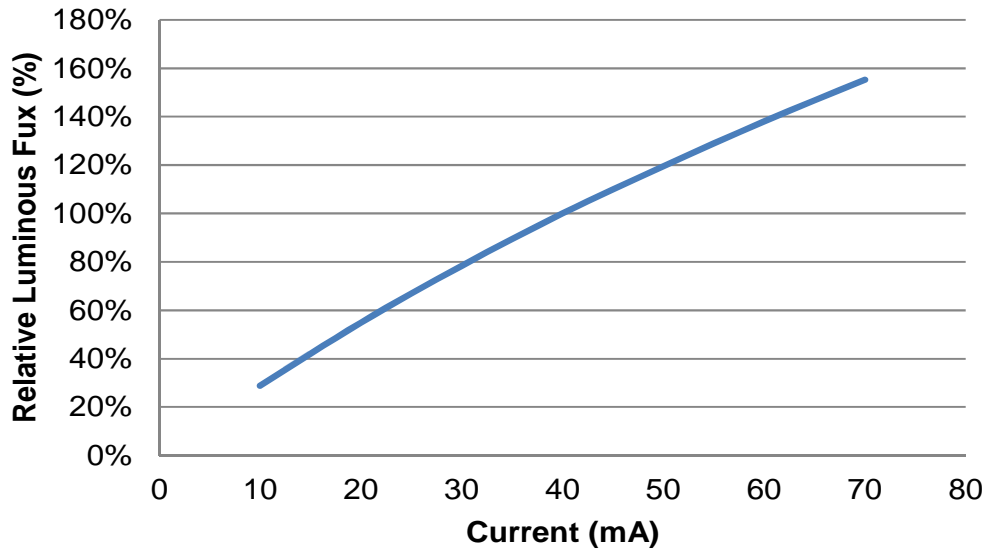

Fig 1. Typical relative luminous flux vs. forward current of LTPL-P05DXXXX

Current (mA)	VF (V)	Current (mA)	VF (V)	Lumen (lm)	
				2700K	3000K
10	88.2	5	176.4	96	101
20	91.9	10	183.8	184	193
30	95.1	15	190.2	263	276
40	97.8	20	195.6	335	352
50	100.4	25	200.8	400	420
60	102.8	30	205.6	463	486
70	105.2	35	210.4	520	546

Notes

1. Black current-voltage data is read by using external parallel connection; gray is by series connection.

LED HIGH POWER P05 Product Series

4.2 Relative Flux vs. Current of LTPL-P05EXXX at 25°C

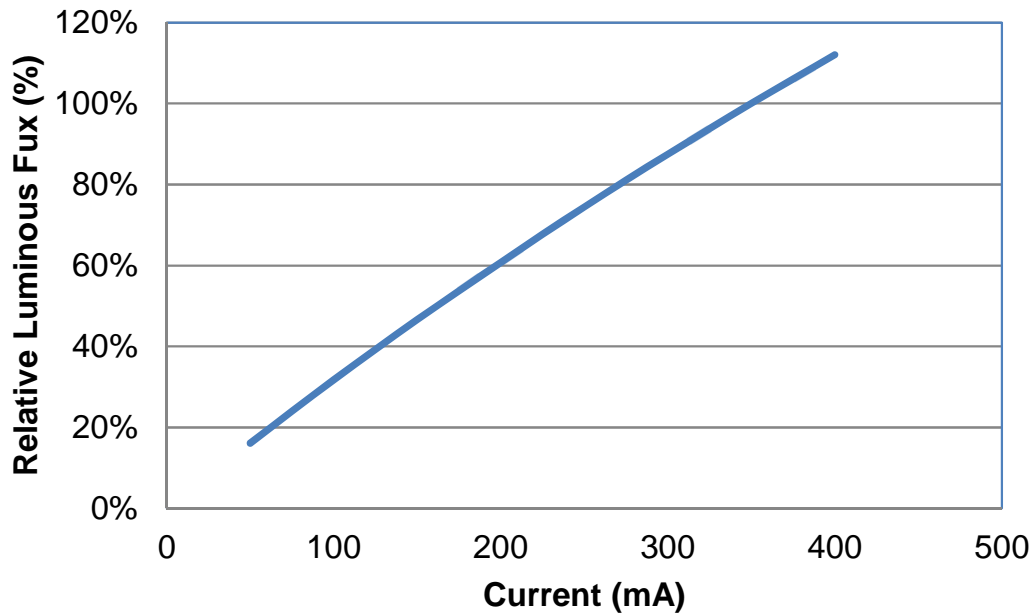

Fig 2. Typical relative luminous flux vs. forward current of LTPL-P05EXXX

Current (mA)	VF (V)	Current (mA)	VF (V)	Lumen (lm)				
				2700K	3000K	4000K	5000K	5700K
50	10.7	16.7	32.1	67	70	72	73	76
100	11.0	33.3	33.1	132	139	142	145	149
150	11.3	50.0	33.9	194	204	208	212	219
200	11.5	66.7	34.6	253	266	271	277	285
250	11.7	83.3	35.2	310	326	332	339	349
300	11.9	100.0	35.8	364	383	391	398	410
350	12.1	116.7	36.3	417	438	458	496	479
400	12.3	133.3	36.9	466	490	500	510	525

Notes

1. Black current-voltage data is read by using external parallel connection; gray is by series connection.

LED HIGH POWER P05 Product Series

4.3 Relative Spectral Distribution vs. Wavelength Characteristics at 25°C & 85°C

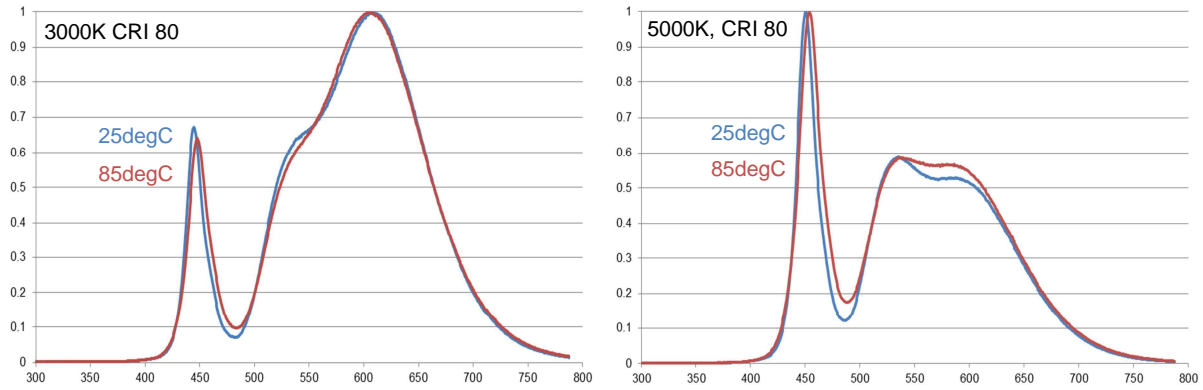

Fig 3. Relative Spectral Distribution at $T_j = 25^\circ\text{C}$ & 85°C

4.4 Typical Spatial Radiation Pattern

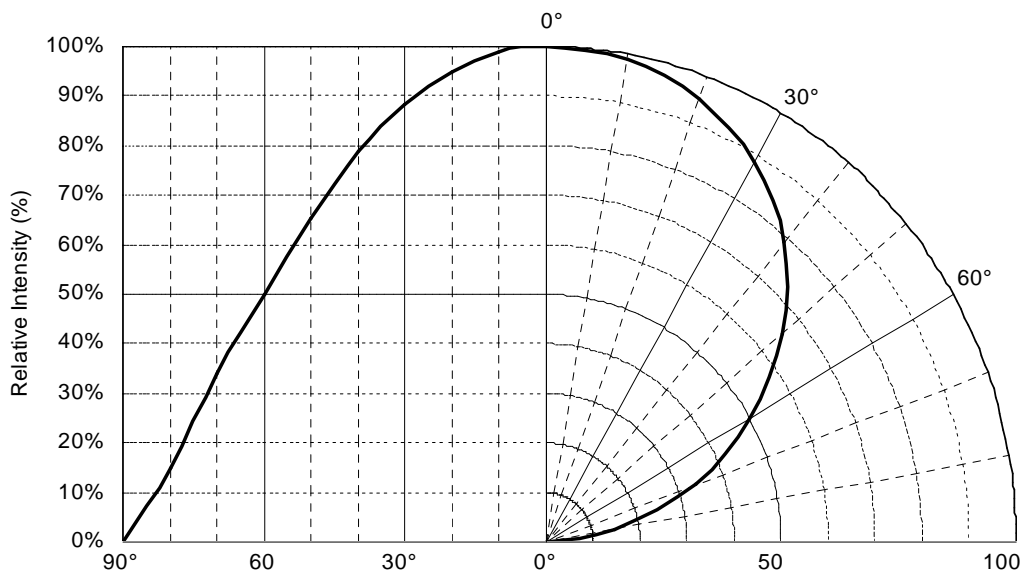

Fig 4. Typical Spatial Radiation Pattern

LED HIGH POWER P05 Product Series

4.5 Forward Current vs. Forward Voltage at 25°C

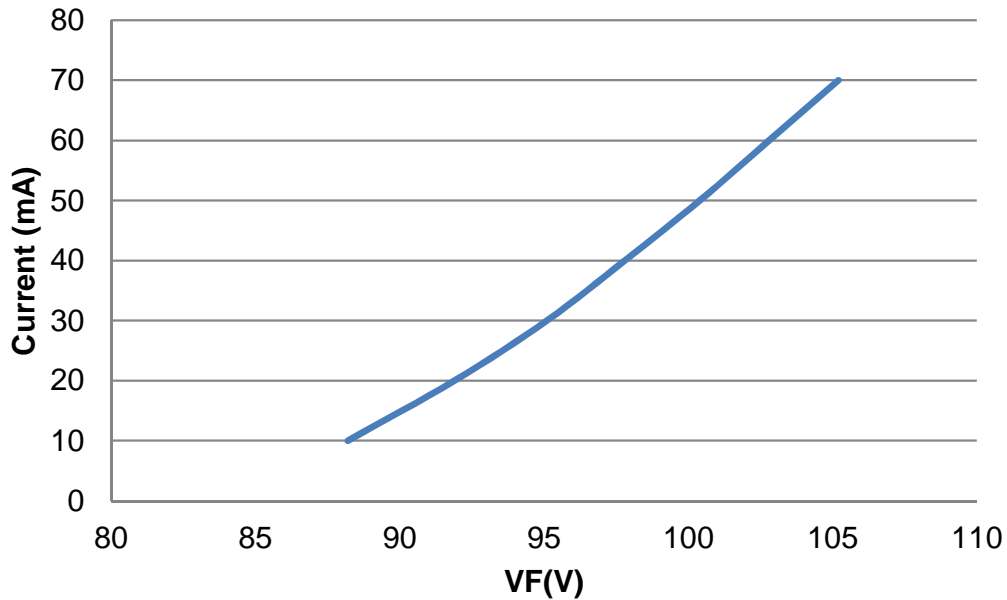

Fig 5. Forward Current vs. Forward Voltage of LTPL-P05DXXXX

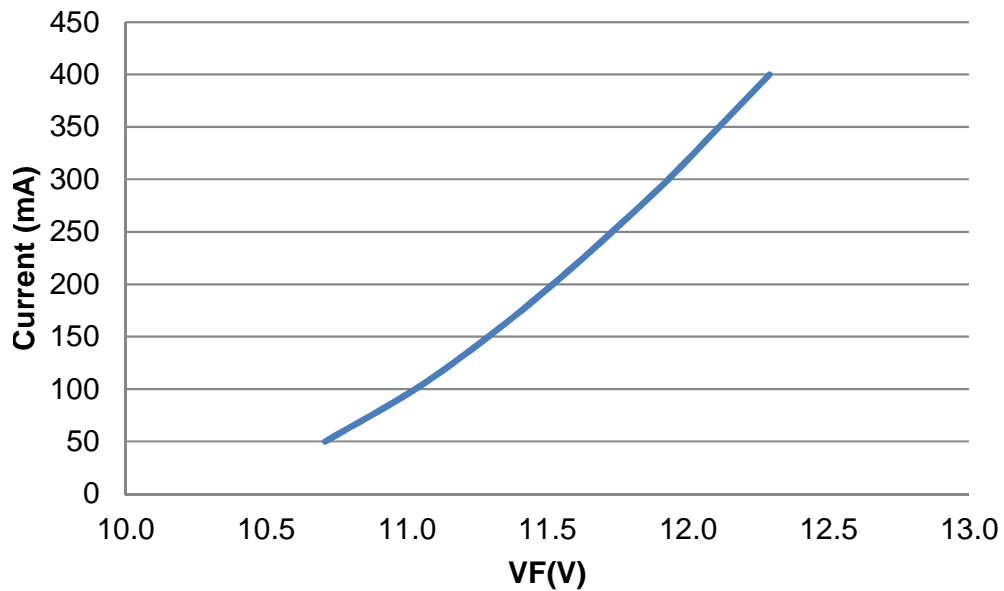

Fig 6. Forward Current vs. Forward Voltage of LTPL-P05EXXXX

**LED HIGH POWER
P05 Product Series**

4.6 Maximum Forward Current vs. Ambient Temperature

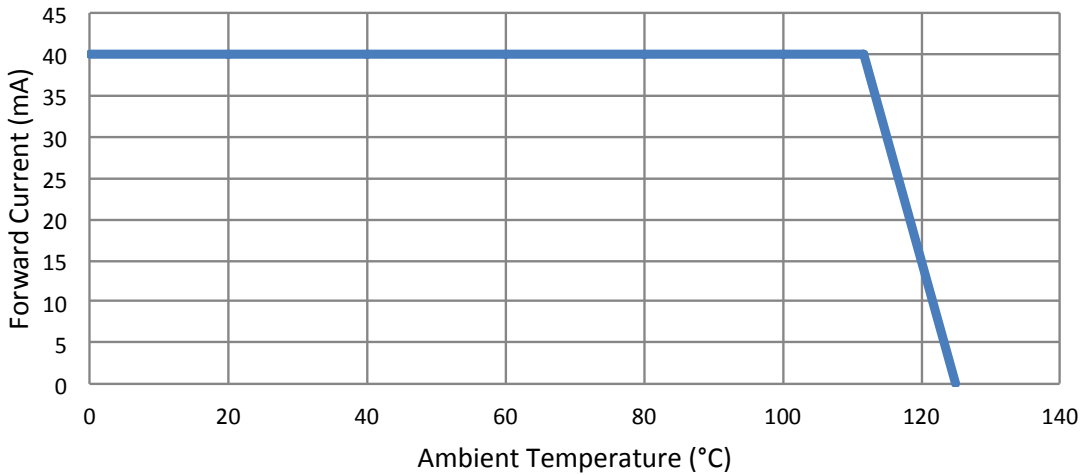

Fig 7. Forward Current Degrading Curve of LTPL-P05DXXXX

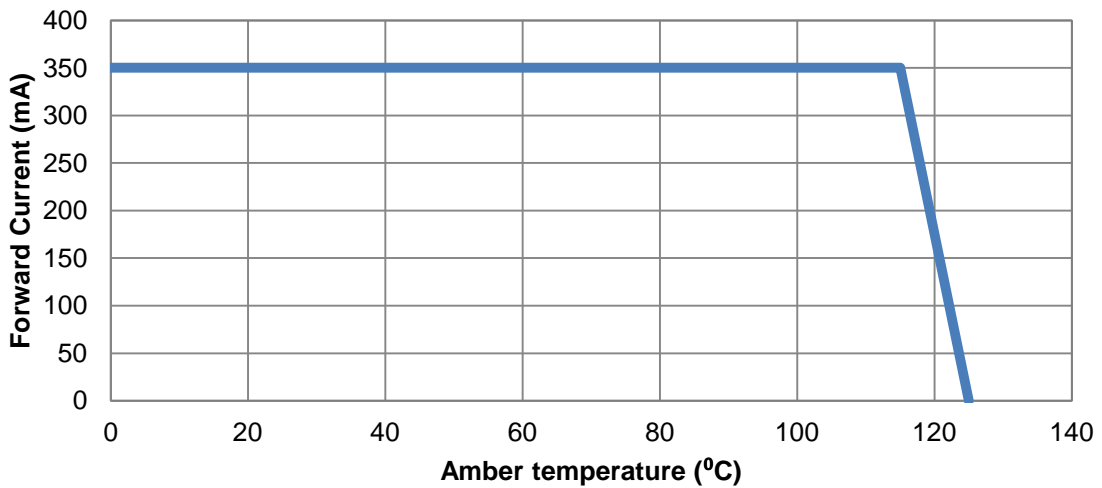

Fig 8. Forward Current Degrading Curve of LTPL-P05EXXXX

LED HIGH POWER P05 Product Series

5. VF Bin Definition

5.1 Forward Voltage Binning Parameter at 25°C

■ LTPL-P05DXXXX

Parameter	Bin	Symbol	Min	Max	Unit	Condition
Forward Voltage	V1	VF	97	101	V	IF = 40mA
Forward Voltage	V2	VF	101	105	V	IF = 40mA
Forward Voltage	V3	VF	105	109	V	IF = 40mA
Forward Voltage	V4	VF	109	113	V	IF = 40mA

■ LTPL-P05EXXXX

Parameter	Bin	Symbol	Min	Max	Unit	Condition
Forward Voltage	V1	VF	11.6	12.0	V	IF = 350mA
Forward Voltage	V2	VF	12.0	12.4	V	IF = 350mA
Forward Voltage	V3	VF	12.4	12.8	V	IF = 350mA
Forward Voltage	V4	VF	12.8	13.2	V	IF = 350mA

LED HIGH POWER P05 Product Series

6. Flux Bin Definition

6.1 Luminous Flux Binning Parameter at 25°C

■ LTPL-P05DXXXX

CRI 80 Series

2700K

Parameter	Bin	Symbol	Min	Max	Unit	condition
Luminous Flux	BD	ΦV	285	315	lm	If=40mA
	DF		315	345		
	FH		345	375		
	HJ		375	405		
	JL		405	435		
	LN		435	465		

3000K

Parameter	Bin	Symbol	Min	Max	Unit	condition
Luminous Flux	CE	ΦV	300	330	lm	If=40mA
	EG		330	360		
	GI		360	390		
	IK		390	420		
	KM		420	450		
	MO		450	480		

■ LTPL-P05EXXXX

CRI 80 Series

2700K

Parameter	Bin	Symbol	Min	Max	Unit	condition
Luminous Flux	HJ	ΦV	375	405	lm	If=350mA
	JL		405	435		
	LN		435	465		
	NP		465	495		
	PR		495	535		
	RT		535	575		

LED HIGH POWER P05 Product Series

3000K

Parameter	Bin	Symbol	Min	Max	Unit	condition
Luminous Flux	IK	ΦV	390	420	lm	If=350mA
	KM		420	450		
	MO		450	480		
	OQ		480	515		
	QS		515	555		
	SU		555	600		

4000K

Parameter	Bin	Symbol	Min	Max	Unit	condition
Luminous Flux	JL	ΦV	405	435	lm	If=350mA
	LN		435	465		
	NP		465	495		
	PR		495	535		
	RT		535	575		
	TV		575	625		

5000K

Parameter	Bin	Symbol	Min	Max	Unit	condition
Luminous Flux	MO	ΦV	450	480	lm	If=350mA
	OQ		480	515		
	QS		515	555		
	SU		555	600		
	UW		600	650		
	WY		650	700		

5700K

Parameter	Bin	Symbol	Min	Max	Unit	condition
Luminous Flux	LN	ΦV	435	465	lm	If=350mA
	NP		465	495		
	PR		495	535		
	RT		535	575		
	TV		575	625		
	VX		625	675		

LED HIGH POWER P05 Product Series

7. Color Bin Definition

7.1 Chromaticity Coordinate Groups at 25°C

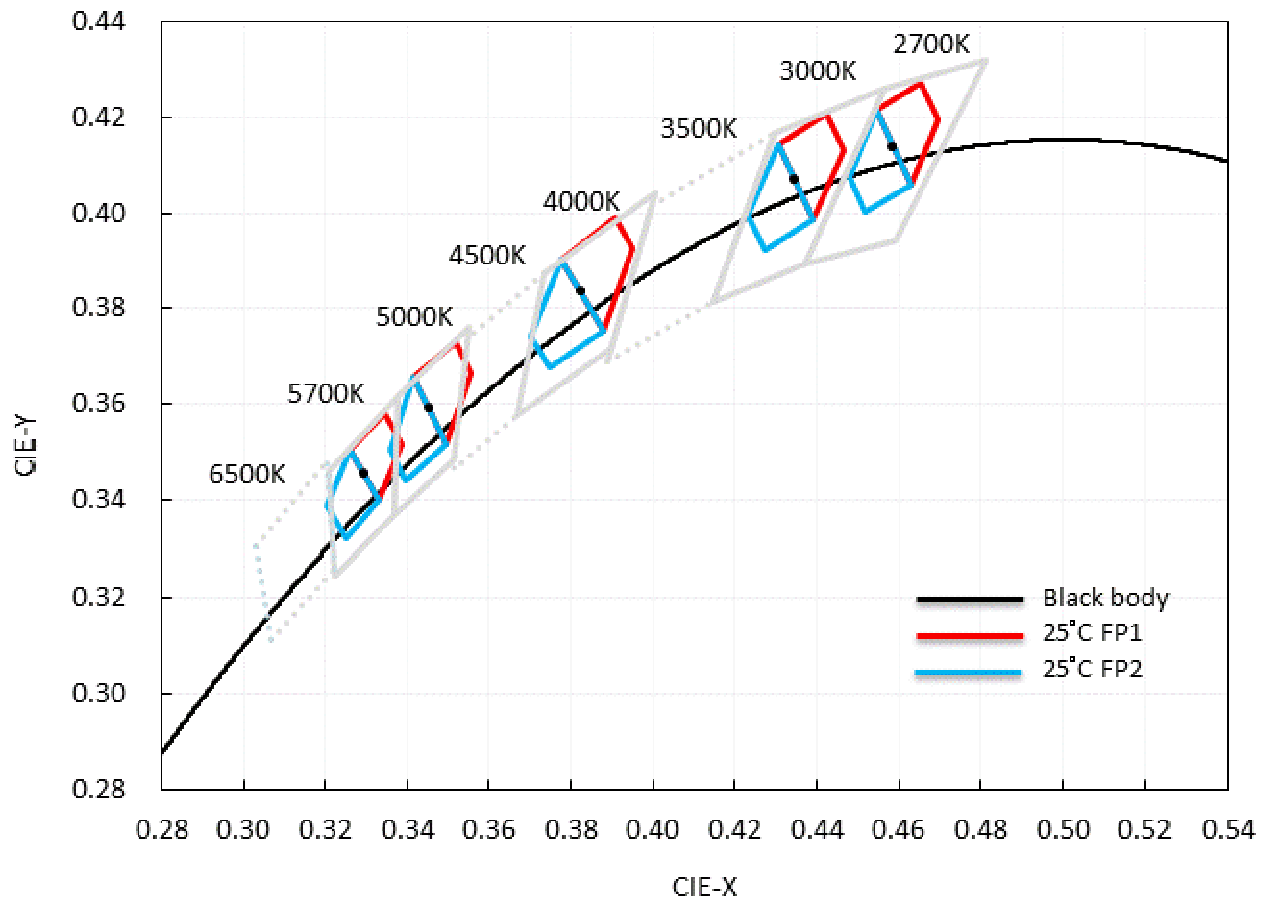

Notes

2. The Chromaticity Coordinate Groups follow ANSI 7-Step MacAdam Quadrangle
3. The (CIE_x, CIE_y) center follow ANSI Quadrangle

LED HIGH POWER P05 Product Series

7.2 Chromaticity Coordinate Category Code Table at 25°C

■ 2700K Series

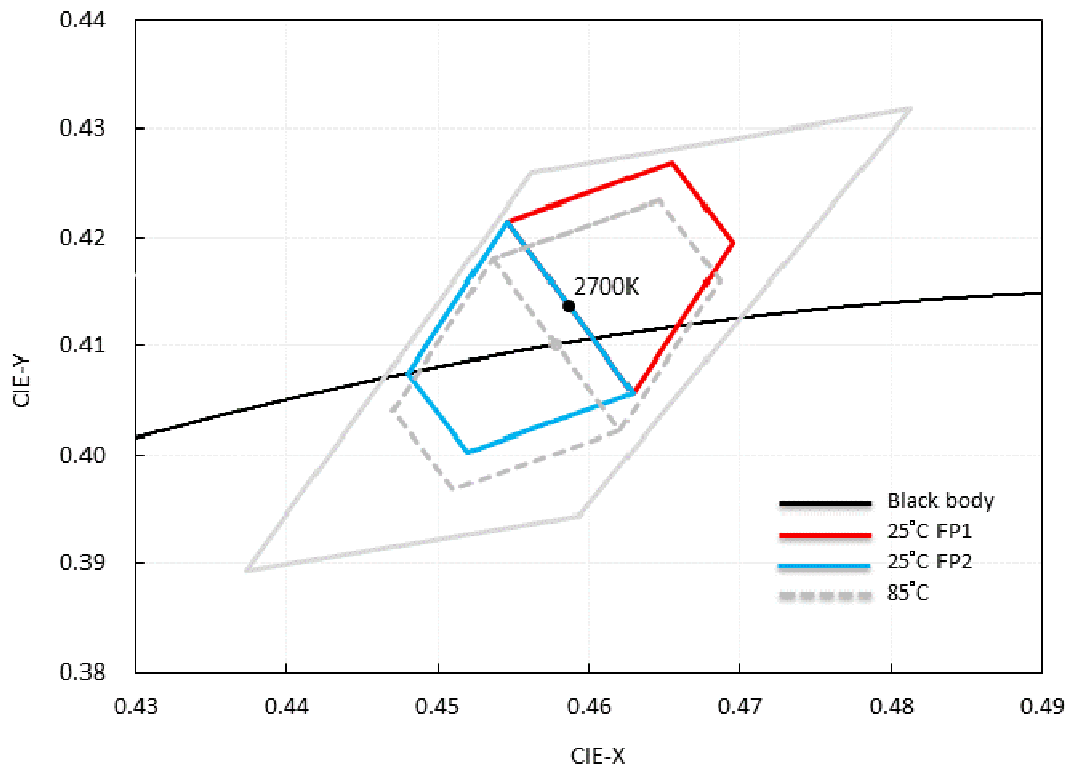

	X	Y
Center point(25C)	0.4587	0.4136
FP1	0.4655	0.4269
	0.4545	0.4215
	0.4629	0.4057
	0.4695	0.4195
	0.4655	0.4269
FP2	0.4545	0.4215
	0.4479	0.4075
	0.4519	0.4003
	0.4629	0.4057
	0.4545	0.4215
Center point(85C)	0.4578	0.4101

LED HIGH POWER P05 Product Series

3000K Series

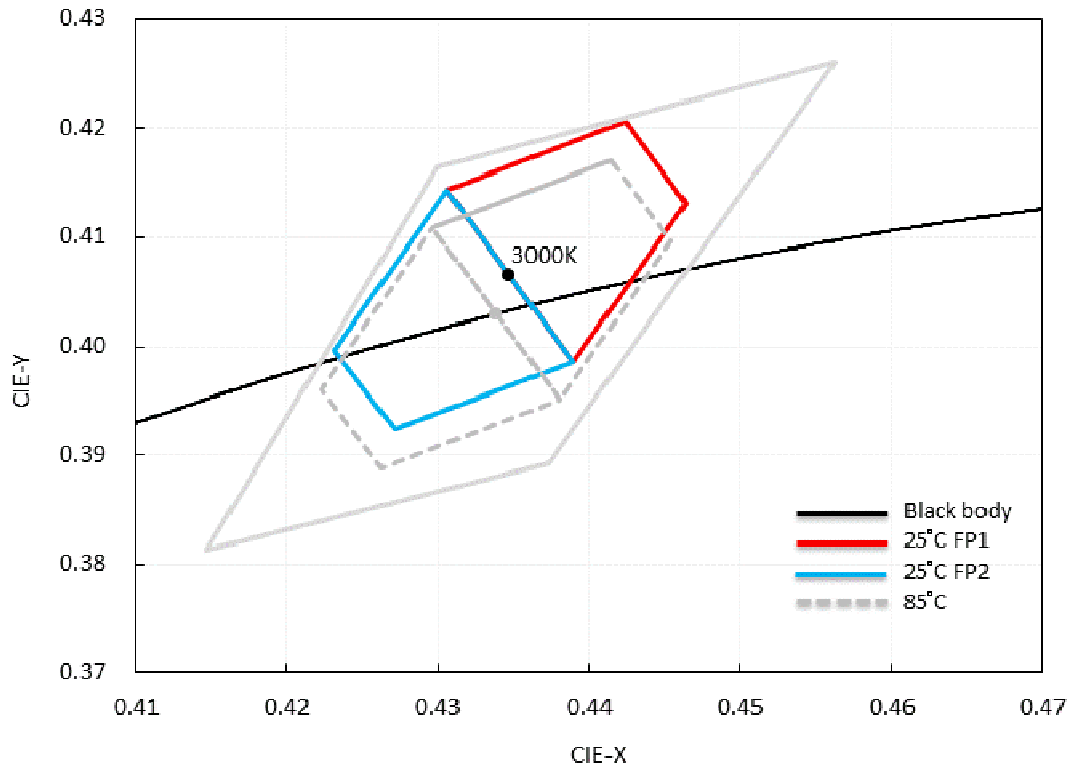

	X	Y
Center point(25C)	0.4347	0.4065
FP1	0.4423	0.4206
	0.4305	0.4144
	0.4389	0.3986
	0.4463	0.4132
	0.4423	0.4206
FP2	0.4305	0.4144
	0.4231	0.3996
	0.4271	0.3924
	0.4389	0.3986
	0.4305	0.4144
Center point(85C)	0.4338	0.4030

LED HIGH POWER P05 Product Series

4000K Series

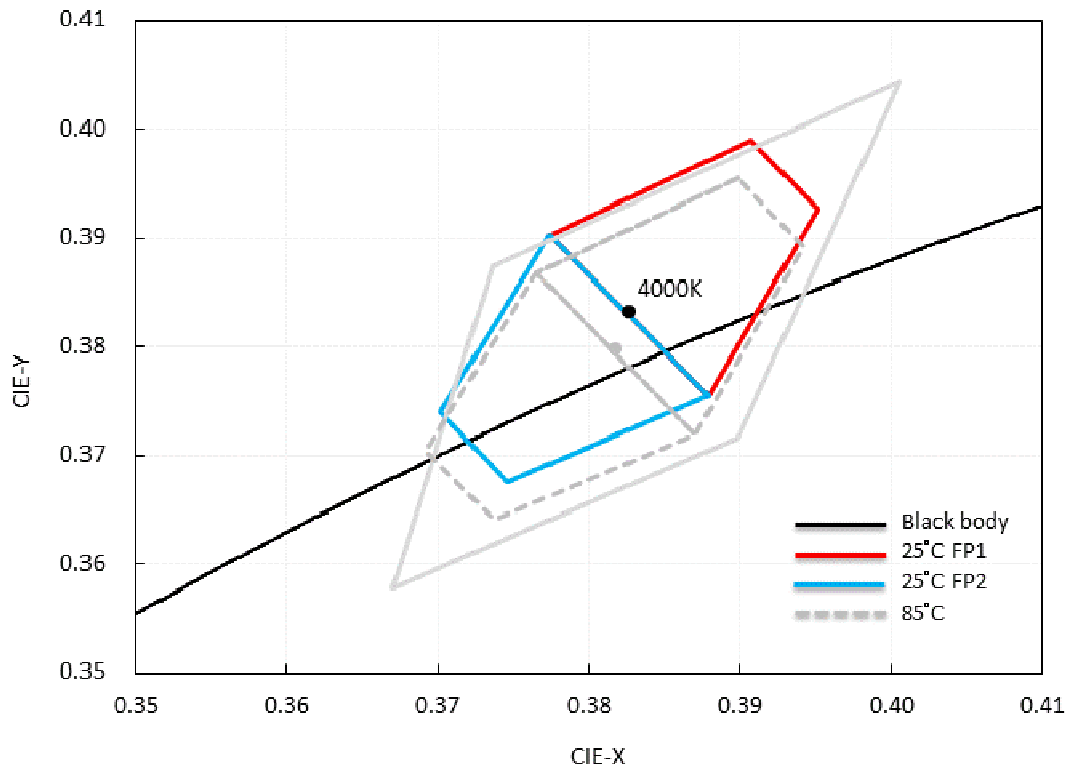

	X	Y
Center point(25C)	0.3827	0.3832
FP1	0.3907	0.3990
	0.3774	0.3903
	0.3879	0.3755
	0.3951	0.3927
	0.3907	0.3990
FP2	0.3774	0.3903
	0.3701	0.3740
	0.3746	0.3676
	0.3879	0.3755
	0.3774	0.3903
Center point(85C)	0.3818	0.3797

LED HIGH POWER P05 Product Series

5000K Series

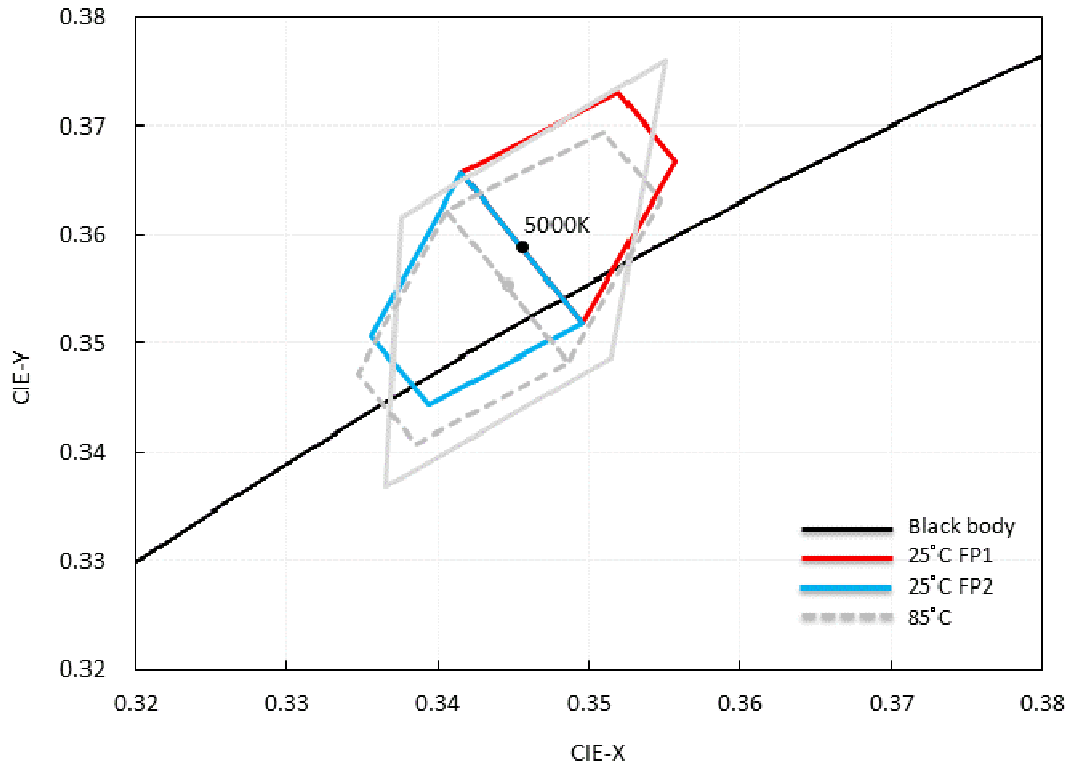

	X	Y
Center point(25C)	0.3456	0.3588
FP1	0.3519	0.3730
	0.3415	0.3657
	0.3495	0.3518
	0.3557	0.3667
	0.3519	0.3730
FP2	0.3415	0.3657
	0.3356	0.3507
	0.3394	0.3443
	0.3495	0.3518
	0.3415	0.3657
Center point(85C)	0.3447	0.3553

LED HIGH POWER P05 Product Series

■ 5700K Series

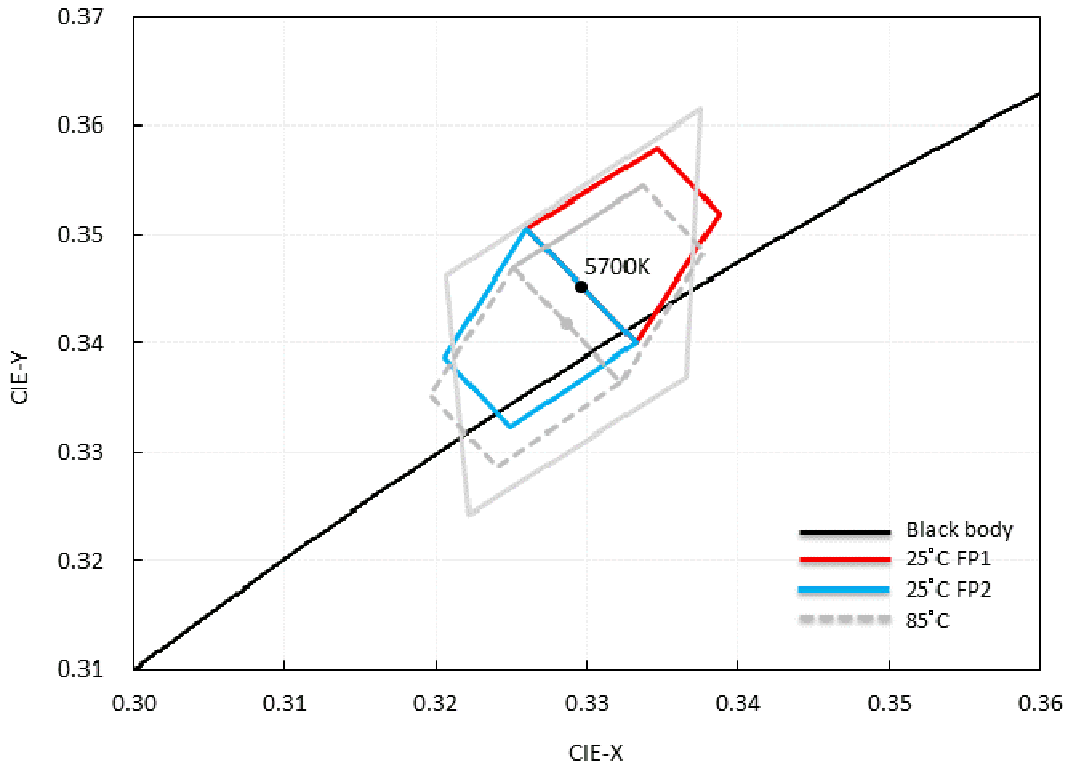

	X	Y
Center point(25C)	0.3296	0.3452
FP1	0.3346	0.3580
	0.3260	0.3505
	0.3332	0.3400
	0.3387	0.3519
	0.3346	0.3580
FP2	0.3260	0.3505
	0.3205	0.3387
	0.3249	0.3322
	0.3332	0.3400
	0.3260	0.3505
Center point(85C)	0.3287	0.3417

LED HIGH POWER P05 Product Series

8. Reflow Soldering Characteristics

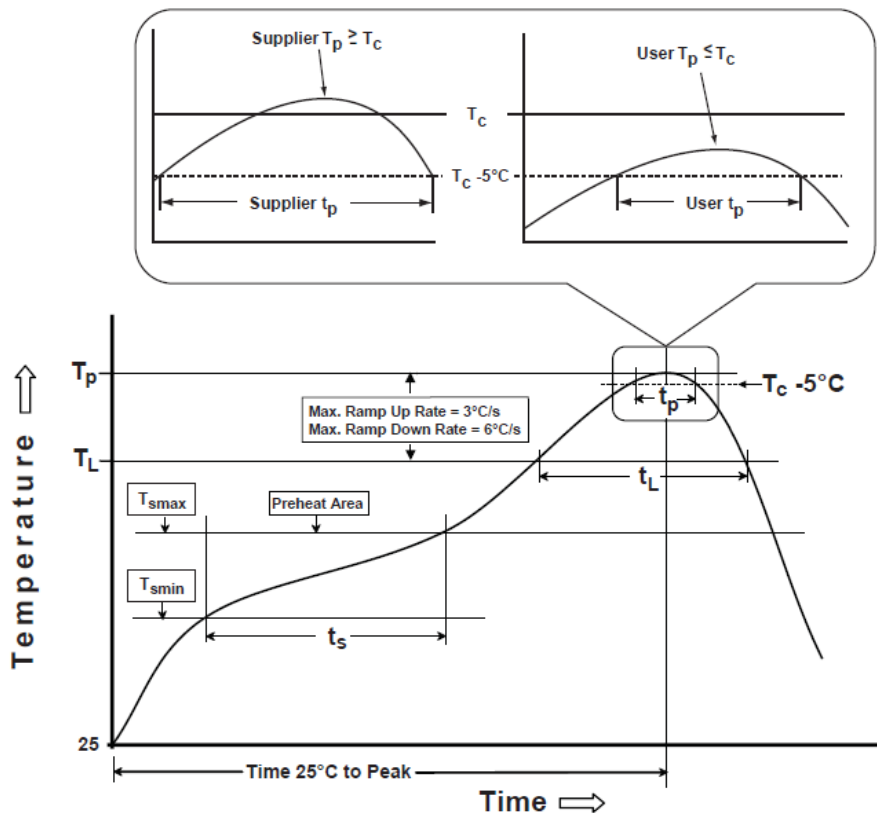

Profile Feature	Lead Free Assembly
Average Ramp-Up Rate (T_{Smax} to T_P)	3°C / second max
Preheat Temperature Min (T_{Smin})	150°C
Preheat Temperature Max (T_{Smax})	200°C
Preheat Time (t_{Smin} to t_{Smax})	60 – 180 seconds
Time Maintained Above Temperature (T_L)	217°C
Time Maintained Above Time (t_L)	60 – 150 seconds
Peak / Classification Temperature (T_P)	255°C
Time Within 5°C of Actual Peak Temperature (t_p)	5 seconds
Ramp – Down Rate	6°C / second max
Time 25°C to Peak Temperature	8 minutes max

LED HIGH POWER P05 Product Series

Notes:

1. The LEDs can be soldered using the reflow soldering or hand soldering method. The recommended hand soldering condition is 350°C max. and 2secs max. for one time only, and the recommended reflow soldering condition is 260°C max. and 5secs max. for three times max.
2. All temperatures refer to topside of the package, measured on the package body surface.
3. The soldering condition referring to J-STD-020B. The storage ambient for the LEDs should not exceed 30°C temperature or 70% relative humidity. It is recommended that LEDs out of their original packaging are soldered within one week. For extended storage out of their original packaging, it is recommended that the LEDs were stored in a sealed container with appropriate desiccant, or desiccators with nitrogen ambient. If the LEDs were unpacked more than 168hrs, baking the LEDs at 60°C for 60 minutes before soldering process.
4. The soldering profile could be further referred to different soldering grease material characteristic. The grease vendor will provide this information.
5. A rapid-rate process is not recommended for the LEDs cooling down from the peak temperature.
6. Although the recommended reflow conditions are specified above, the reflow or hand soldering condition at the lowest possible temperature is desirable for the LEDs.
7. LiteOn cannot make a guarantee on the LEDs which have been already assembled using the dip soldering method.

LED HIGH POWER P05 Product Series

9. Reliability Test Plan

■ LTPL-P05DXXXX

No	Test item	Condition	Duration	Number of Failed
1	High Temperature Operating Life (HTOL)	Tc=105°C, IF=40mA DC (0, 250, 500, 750, 1000hrs)	1K hrs	0/20
2	High Temperature Operating Life (HTOL)	Tc=85°C, IF=40mA DC (0, 250, 500, 750, 1000hrs)	1K hrs	0/20
3	Room Temperature Operating Life (RTOL)	Tc=55°C, IF=40mA DC (0, 250, 500, 750, 1000hrs)	1K hrs	0/20
4	Wet High Temperature Operating (WHTOL)	85°C/85%RH, IF=40mA DC 30 min ON/OFF	1K hrs	0/20
5	Power Temperature Cycle (PTMCL)	-40°C to 105°C 15minutes dwell/15minutes transfer 5 minutes ON/5 minutes OFF IF=40mA DC	1K cycles	0/20
6	Non-Operating Thermal Shock (TMSK)	-40°C to 125°C 30minutes dwell, <10 seconds transfer measure each 250 cycles (continues to fail, more than 1k cycles)	1K cycles	0/20
7	Fast switch Cycling Test	40000cycles, 2 mins On/Off, Room temperature(25°C+/-5°C), measurement in every 5000cycles	40K cycles	0/20

Notes:

1. Operating life test are mounted on thermal heat sink
2. Storage item are only component, not put on heat sink.

Criteria for Judging the Damage

Item	Symbol	Test Condition	Criteria for Judgment	
			Min.	Max.
Forward Voltage	Vf	IF=Typical Current	-10%	+10%
Luminous Flux	Lm	IF=Typical Current	-15%	+15%
CCX&CCY	X,Y	IF=Typical Current	-0.007	+0.007

LED HIGH POWER P05 Product Series

■ LTPL-P05EXXXX

No	Test item	Condition	Duration	Number of Failed
1	High Temperature Operating Life (HTOL)	Tc=105°C, IF=350mA DC (0, 250, 500, 750, 1000hrs)	1K hrs	0/20
2	High Temperature Operating Life (HTOL)	Tc=85°C, IF=350mA DC (0, 250, 500, 750, 1000hrs)	1K hrs	0/20
3	Room Temperature Operating Life (RTOL)	Tc=55°C, IF=350mA DC (0, 250, 500, 750, 1000hrs)	1K hrs	0/20
4	Wet High Temperature Operating (WHTOL)	85°C/85%RH, IF=350mA DC 30 min ON/OFF	1K hrs	0/20
5	Power Temperature Cycle (PTMCL)	-40°C to 105°C 15minutes dwell/15minutes transfer 5 minutes ON/5 minutes OFF IF=350mA DC	1K cycles	0/20
6	Non-Operating Thermal Shock (TMSK)	-40°C to 125°C 30minutes dwell, <10 seconds transfer measure each 250 cycles (continues to fail, more than 1k cycles)	1K cycles	0/20
7	Fast switch Cycling Test	40000cycles, 2 mins On/Off, Room temperature(25°C+/-5°C), measurement in every 5000cycles	40K cycles	0/20

Notes:

- Operating life test are mounted on thermal heat sink
- Storage item are only component, not put on heat sink.

Criteria for Judging the Damage

Item	Symbol	Test Condition	Criteria for Judgment	
			Min.	Max.
Forward Voltage	Vf	IF=Typical Current	-10%	+10%
Luminous Flux	Lm	IF=Typical Current	-15%	+15%
CCX&CCY	X,Y	IF=Typical Current	-0.007	+0.007

**LED HIGH POWER
P05 Product Series**

10. Recommend Soldering Pad Layout

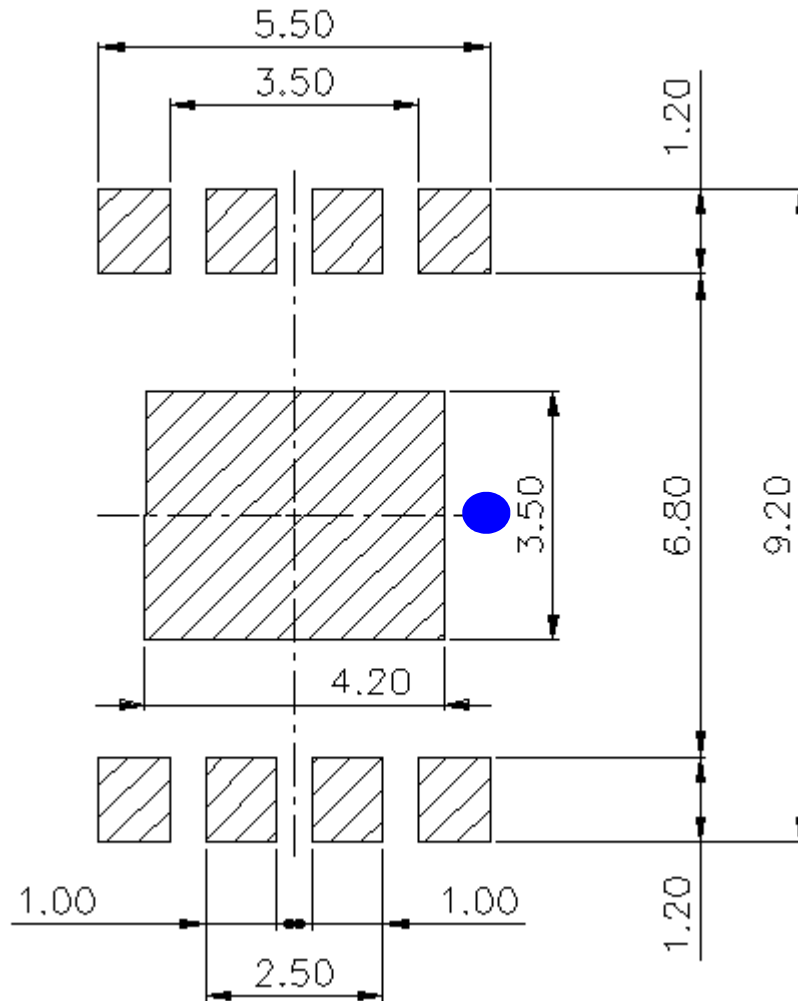

Notes:

1. All dimensions are in millimeters
2. The Thermal pad is electrically isolated.
3. Blue point is LITEON suggest Ts test point and distance between solder should be less than 1.5mm

LED HIGH POWER P05 Product Series

11. Package Dimensions of Tape and Reel

Reel Packaging

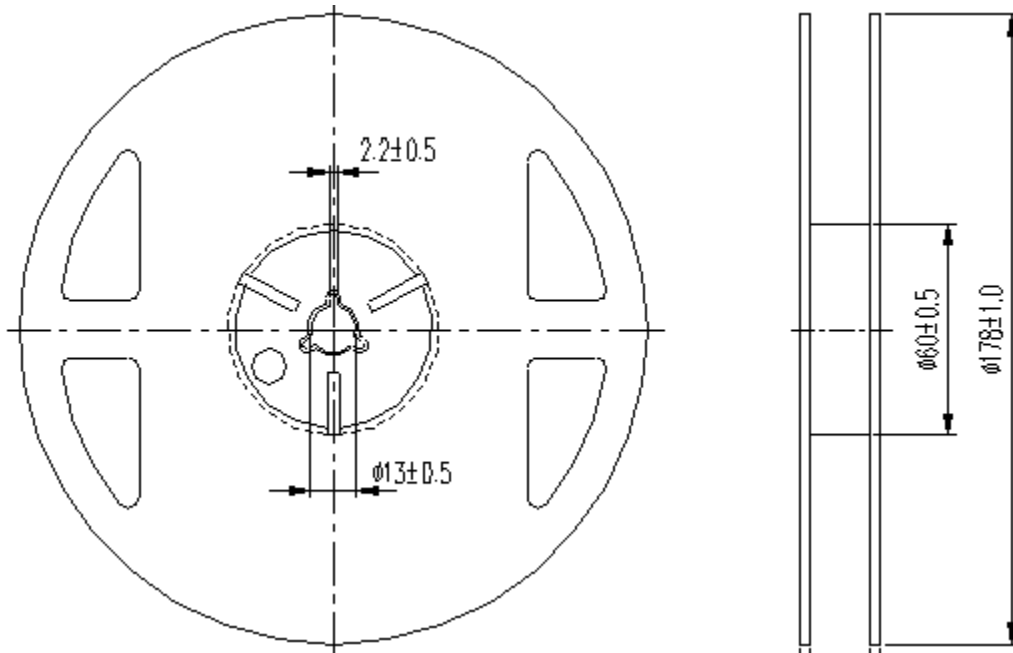

Note: The tolerances unless mentioned is ± 0.1 mm, Unit=mm

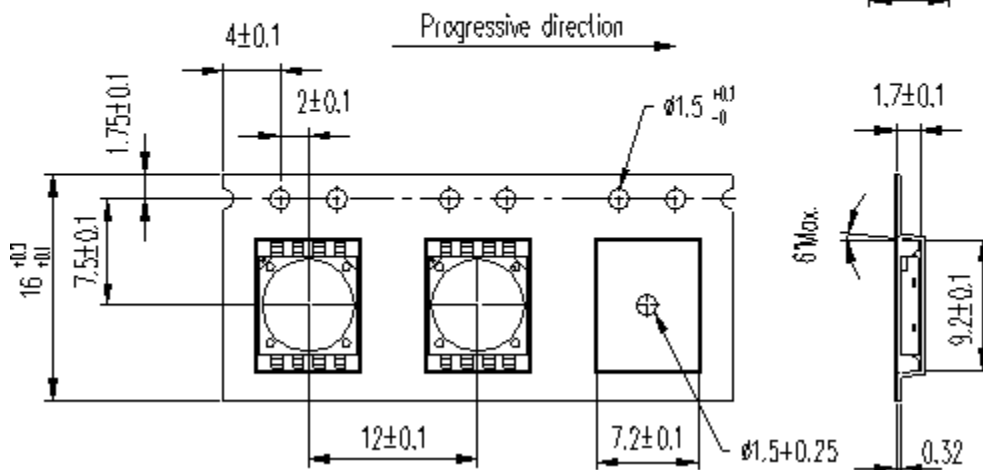

Note:

1. All dimensions are in millimeters.
2. Empty component pockets sealed with top cover tape.

LED HIGH POWER P05 Product Series

12. Cautions

Application

The LEDs described here are intended to be used for ordinary electronic equipment (such as office equipment, communication equipment and household applications). Consult Liteon's Sales in advance for information on applications in which exceptional reliability is required, particularly when the failure or malfunction of the LEDs may directly jeopardize life or health (such as in aviation, transportation, traffic control equipment, medical and life support systems and safety devices).

Storage

This product is qualified as Moisture Sensitive Level 3 per JEDEC J-STD-020 Precaution when handling this moisture sensitive product is important to ensure the reliability of the product.

The package is sealed:

The LEDs should be stored at 30°C or less and 90%RH or less. And the LEDs are limited to use within one year, while the LEDs is packed in moisture-proof package with the desiccants inside.

The package is opened:

The LEDs should be stored at 30 °C or less and 60%RH or less. Moreover, the LEDs are limited to solder process within 168hrs. If the Humidity Indicator shows the pink color in 10% even higher or exceed the storage limiting time since opened, that we recommended to be with workable desiccants in original package.

The soldering condition referring to J-STD-020B. If the LEDs were unpacked more than 72 hrs, baking the LEDs at 60°C for 24 hrs before soldering process.

Drive Method

An LED is a current-operated device. In order to ensure intensity uniformity on multiple LEDs connected in parallel in an application, it is recommended that a current limiting resistor be incorporated in the drive circuit, in series with each LED as shown in Circuit A below.

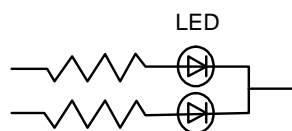

Circuit model A

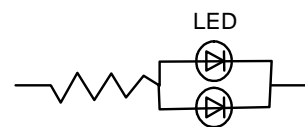

Circuit model B

(A) Recommended circuit.

(B) The brightness of each LED might appear different due to the differences in the I-V characteristics of those LEDs.

LED HIGH POWER P05 Product Series

ESD (Electrostatic Discharge)

Static Electricity or power surge will damage the LED. Suggestions to prevent ESD damage:

- Use of a conductive wrist band or anti-electrostatic glove when handling these LEDs.
- All devices, equipment, and machinery must be properly grounded.
- Work tables, storage racks, etc. should be properly grounded.
- Use ion blower to neutralize the static charge which might have built up on surface of the LED's plastic lens as a result of friction between LEDs during storage and handling.

ESD-damaged LEDs will exhibit abnormal characteristics such as high reverse leakage current, low forward voltage, or "no light up" at low currents.

To verify for ESD damage, check for "light up" and VF of the suspect LEDs at low currents.